



PROFESSIONAL

CATALOGUE 2024 / 25 | EN 



SINGING ROCK COMPANY

We are climbers who work for climbers

We put not only our experience, but also our enthusiasm into our professional equipment. We proudly do it in Czechia.

We are here for those who want to see the vertical world as it is, without pretence and unrealistic ballast. We do not embellish or hide anything. We respect the purity of work at height and that's how we approach our products.



read more
about our
company



We offer solutions

We always look for an ideal and complex solution of a product, situation or communication, so that our customers are satisfied.



SINGING ROCK VALUES

We are climbers who work for climbers

Pure experience

It is a part of our products and manner of communication. We share it with every interaction.

Climbers for climbers

We understand the world of our customers and we talk to them accordingly. We make our professional equipment as if we were making it for ourselves.



Functionality

The value of real workers at height who don't need fancy and glitz. They are self-confident and rely on the equipment they use.

MISSION

We make products for your vertical world.







We bring simplicity, authenticity and fair behaviour to climbing and working at heights.



read more about our history

MILESTONES

From **TUCAN** to **SINGING ROCK**. From "Tatman" to the "Arrow". From one sewing machine and 40 m2 of a workshop at home to three manufacturing plants and more than 170 employees. These and more are the milestones of SINGING ROCK.

<p>1992</p> <p>Foundation of SINGING ROCK by two professional climbers</p>	<p>1995</p> <p>SINGING ROCK enters the work at height segment, complementing its outdoor climbing business</p>	<p>2000</p> <p>QMS certification according to ISO 9001 (and Art. II B of Council Directive 89/686/EEC)</p> <p>Investment into own factory in Poniklá</p>	<p>2001</p>  <p>Redesign corporate image</p> <p>Launch of in-house developed dynamic and static ropes</p>	<p>2003</p> <p>Launch of own designed line of carabiners and other hardware</p>
<p>2005</p>  <p>Introduction of POLYGON brand and opening of the first center in Poniklá</p>	<p>2008</p>  <p>Acquisition of SINGING ROCK by ARX Equity Partners</p>	<p>2009</p> <p>Merger with LANEX</p> <p>Investment in a second training center in Kladno</p> <p>Acquisition of new production space for textile production in Semily</p>	<p>2011</p>  <p>Acquisition of Raveltik, incorporating capabilities in the hardware segment and expanded coverage of the mountaineering and ice climbing segments</p>	<p>2013</p>  <p>POLYGON's training centers in Poniklá and Kladno become certified by IRATA</p> <p>Spin-off from LANEX and reorganization as an independent entity</p>
<p>2015</p> <p>ARX Private Equity Partners sold 100% share in SINGING ROCK to Mr. Rudolf Bochenek with a majority share and Rudolf Gregořica as minority partner</p>	<p>2017</p> <p>Mr. Bochenek acquires shares of Mr. Gregořica and fully incorporates Singing Rock to BR Group holding</p>	<p>2019</p> <p>Presentation of the Polygon Partner franchise system</p> <p>QMS and certificates transfer from 89/686/EEC PPE Directive to 2016/425 PPE Regulation (EU)</p>	<p>2020</p> <p>Refreshment of the brand visual</p>	<p>2022</p> <p>30th Anniversary</p> 

PRODUCTION

PRODUCTION & QUALITY CONTROL

Although we are open to the world, the heart of SINGING ROCK beats in the Czech Republic. The headquarter, production, training and testing centre is located in Poniklá. Our textile production plant is situated in Semily. The production of metal products and components is placed in Sudkov. The Kladno training centre for work at height is just 20 min from Prague. Four locations in the Czech Republic, including three manufacturing plants and two training centres bring you the equipment and services for your vertical playground.



DISTRIBUTION

Singing Rock supplies products to more than 65 countries worldwide, through its network of distributors and agents. Thanks to them, you can find us wherever they understand climbing and working at heights.



find your
SINGING ROCK
dealer

DISTRIBUTION

KNOWLEDGE & EXPERIENCE

Meeting minimum requirements is obvious. We go further by performing the tests to simulate all kind of usage as the basis for our further development. In our laboratory we can test our products on several testing machines f.e. a helmet testing machine or cycling hydraulic machine for fatigue tests of movable components and elastic webbings. Laboratory tests are, of course, complemented by testing and validation in the real environment.



RESEARCH & DEVELOPMENT

For more than 30 years, SINGING ROCK has built on its experience and knowledge in designing and manufacturing products for your vertical world. Developing our products requires expertise in a wide range of different materials and manufacturing technologies. Modern tools help our development team to create products to your and our satisfaction.

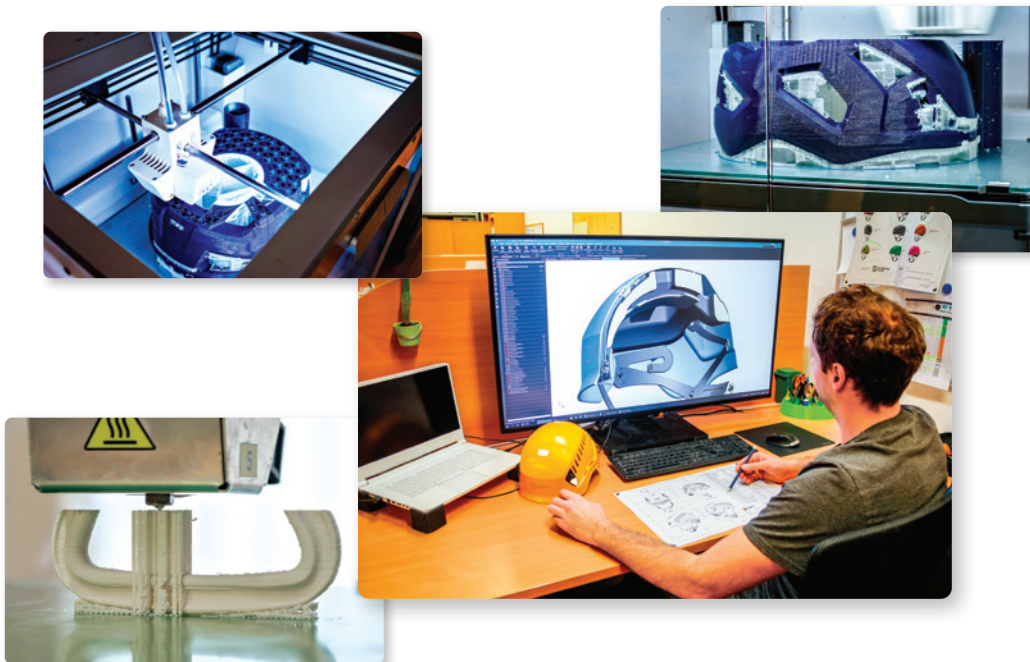

EFFICIENCY

EFFICIENCY

We run lean management system with horizontal organisation structure. Thanks to this structure we are able to react immediately and customize our products and service for your specific needs.

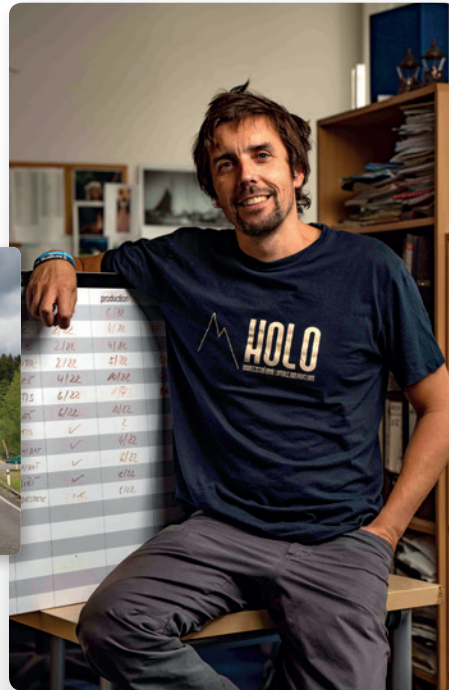

SUSTAINABILITY

We bear the responsibility to keep our planet green and to preserve its riches for our kids. Singing Rock is supporting by its membership in the European Outdoor Conservaton Association environmental activities all around the world.



SUSTAINABILITY





SENVION

MM100



HARNESSES

ROPE ACCESS
FALL ARREST
FULL BODY
CHEST
SIT HARNESSES
ARBORICULTURE
RESCUE
ACCESSORIES





SPEED BUCKLE

Fast donning and adjustment

Singing Rock SPEED buckle is the side quick release buckle for easy operation with the harness. SPEED buckle enable fluent and fast adjustment to fit a user's body. The buckle is very durable, made of steel and matches the strict American standard ANSI. The buckle is impossible to open under the loading, also is impossible to lock when the webbing is twisted. Comes in two sizes with a strength 18 kN.



EASY-LOCK BUCKLE

smooth adjusting

Unique buckle with a sliding captive bar matches strict American standards (ANSI, CSA). Its minimum strength is 17.2 kN. No webbing slippage in a buckle. Its construction ensures longtime operation and efficiency (easy releasing and fastening even when dirty and tough webbing). Corrosion resistance is tested by spraying in a salty chamber for a period of 48 hours.



ROCK & LOCK

patented smart buckle system

Easy to lock and open: Only a small amount of finger pressure is needed to lock and to open.

- Fast lace-through: Make the loop, put it through the buckle frame, hook the loop on the cross bar and tighten. It's as easy as that.
- Smart function: Rock&Lock allows you to put on your harness very quickly
- Double safety: Webbing cannot slip through Rock&Lock due to a safety loop at the end of the webbing Spontaneous opening of Rock&Lock is virtually impossible.
- Lightweight and extra strong.
- Excellent operation in all-season conditions: Operation guaranteed even when webbing is wet or frozen.



SINGING ROCK HARNESSES INNOVATIONS

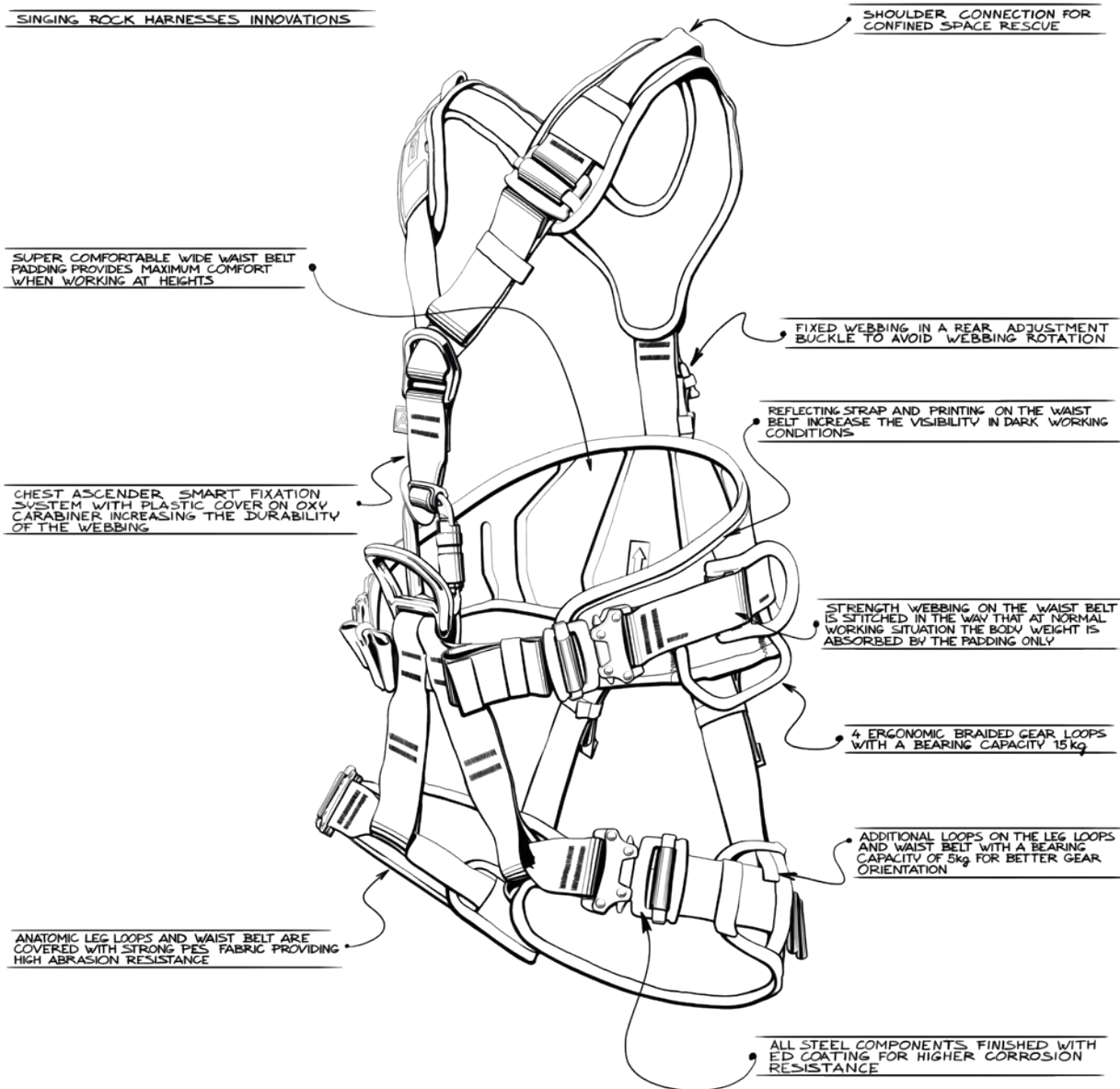

These icons will help you to choose the proper harness regarding the most common and most suitable use:



rope
access



rescue



work
restraint



fall
arrest



intervention



rope park



tree
care

EXPERT 3D / SPEED

W0079DR
black version – W0079DB



Fully adjustable harness for a rope access with wide padded waist belt, leg loops and shoulder straps. Suitable also for work positioning, fall arrest and work restraint situations.

- shoulder straps can be totally removed and the harness can be used as a sit harness only
- super comfortable wide waist belt padding provides maximum comfort when working at height
- strength webbing on the waist belt is stitched in the way that at normal working situation the body weight is absorbed by the padding only
- reflective strap and printing on the waist belt and shoulder padding increase the visibility in dark working conditions
- anatomic leg loops and waist belt are covered with strong PES fabric providing high abrasion resistance
- SPEED buckles enable fluent and fast adjustment to fit a user's body
- OXY triple lock carabiner used for connection of shoulder straps to the main point to increase the space for chest ascender attachment
- chest ascender smart fixation system with plastic cover on the OXY carabiner increasing the durability of the webbing
- shoulder straps and leg loops are independently adjustable
- narrowed padding and webbing on the shoulder straps in a neck area enhance a comfortable work
- front and back attachment points for fall-arrest according to EN 361 marked with additional "A" marking
- rear lower attachment point according to EN 813
- flat rear attachment point does not bear on users back when carrying backpack or breathing apparatus
- front lower attachment point for descender placement or work positioning according to EN 813, EN 358
- 2 side attachment points for work positioning according to EN 358
- heavier items up to 35 kg can be attached to the webbing on the waist belt
- all steel components finished with E coating for higher corrosion resistance
- 4 ergonomic braided gear loops with a bearing capacity 15 kg
- additional loops on the waist belt and leg loops with a bearing capacity of 5 kg offer additional space for the gear and better gear orientation
- wide elastic band on left shoulder strap for the gear attachment (f.e. transmitter)
- slots on the waist belt for PORTER tool holder to carry your industrial tools

Size: S, M/L, XL

Weight: (M/L) 2415 g • 85.19 oz

Max. rated load: 150 kg

CE 1019 • EN 358 • EN 813 • EN 361 • EN 1497



EXPERT 3D / STANDARD

W0078DR
black version – W0078DB



- standard easy-lock buckles enable smooth adjustment
- super comfortable wide waist belt padding provides maximum comfort even during prolonged suspension

Size: S, M/L, XL
Weight: (M/L) 2110 g • 74.43 oz
Max. rated load: 150 kg
CE 1019 • EN 358 • EN 813 • EN 361 • EN 1497



EXPERT 3D / SPEED STEEL

W0080DR



The variant of EXPERT 3D harness according to the North American standards ANSI and NFPA with SPEED buckles, metal elements made of steel, fall indicators and lanyard keepers.

- harness certified according to the newest North American standards ANSI Z359.11-2014 and NFPA 1983 Class III
- ergonomic and removable lanyard keepers on the shoulder straps allow user to store lanyard connectors when not in use - in the event of a fall, the connector is released so that the shock absorber can be safely deployed
- for easier inspection, the harness is equipped with fall indicators placed close to dorsal attachment point which are activated in case of a fall - red label indicates that the harness must be retired

Size: S, M/L, XL
Weight: (M/L) 2830g • 99.83 oz
Max. rated load: 150 kg (140 kg/310 lbs according to ANSI)
ANSI Z359.11-2014 • NFPA 1983 Class III • CE 1019 • EN 358 • EN 813 • EN 361 • EN 1497





PROFI WORKER 3D / SPEED

W0082DR
black version – W0082DB

Fully adjustable harness for a rope access with wide padded waist belt, leg loops and shoulder straps. Suitable also for work positioning, fall arrest and work restraint situation.

- super comfortable wide waist belt padding provides maximum comfort when working at height
- strap that connects the legs loops and shoulders at the back passes freely through the waist belt, which brings increased mobility
- strength webbing on the waist belt is stitched in the way that at normal working situation the body weight is absorbed by the padding only
- reflective strap and printing on the waist belt and shoulder padding increase the visibility in dark working conditions
- anatomic leg loops and waist belt are covered with strong PES fabric providing high abrasion resistance
- SPEED buckles enable fluent and fast adjustment to fit a user's body
- narrowed padding and webbing on the shoulder straps in a neck area enhance a comfortable work
- leg loops connection straps made from durable PES webbing for better abrasion resistance
- front and back attachment points for fall-arrest according to EN 361 marked with additional „A“ marking
- rear lower attachment point according to EN 813
- flat rear attachment point does not bear on users back when carrying backpack or breathing apparatus
- front lower attachment point for descender placement or work positioning according to EN 813, EN 358
- 2 side attachment points for work positioning according to EN 358
- heavier items up to 35 kg can be attached to the webbing on the waist belt
- 4 ergonomic braided gear loops with a bearing capacity 15 kg
- additional loops on the waist belt and leg loops with a bearing capacity of 5 kg offer additional space for the gear and better gear orientation
- wide elastic band on left shoulder strap for the gear attachment (f.e. transmitter)
- slots on the waist belt for PORTER tool holder to carry your industrial tools

Size: S, M/L, XL •

Weight: (M/L) 2075 g • 73.19 oz

Max. rated load: 150 kg

CE 1019 • EN 358 • EN 813 • EN 361 • EN 1497



PROFI WORKER 3D / STANDARD

W0081DR
black version – W0081DB



Fully adjustable harness for a rope access with wide padded waist belt, leg loops and shoulder straps. Also suitable for work positioning, descent, ascent and rescue situations

- standard easy-lock buckles enable smooth adjustment
- super comfortable wide waist belt padding provides maximum comfort even during prolonged suspension

Size: S, M/L, XL •
Weight: (M/L) 1777 g • 62.68 oz
Max. rated load: 150 kg
CE 1019 • EN 358 • EN 813 • EN 361 • EN 1497



TECHNIC

STANDARD – W0063BB
SPEED – W0064BB



TECHNIC STANDARD

TECHNIC SPEED

Fully adjustable full body harness for rope access, work positioning and fall arrest with Easy-Lock or SPEED buckles and steel components.

- front large attachment point for attaching descender or work positioning devices (EN 813, EN 358)
- steel side positioning points according to EN 358 with position adjustment are placed symmetrically and do not interfere at work
- front and rear attachment points for fall arrest (EN 361)
- rear attachment point does not interfere with carrying a backpack or breathing apparatus
- attachment of the CAM CLEAN chest ascender by a mailon and the CAM CLEAN strap
- 2 braided gear loops with a bearing capacity of 5 kg
- additional slots on the waist belt allow you to safely hang expensive equipment (chainsaw, drill...)
- the corrosion resistance of the steel components is tested by spraying in a salt chamber for 48 hours

Size: S, M/L, XL

Weight: (M/L) 2045 g • 72 oz

Max. rated load: 150 kg

CE 1019 • EN 358 • EN 813 • EN 361



TECHNIC ANSI

STANDARD – W0103BB
SPEED – W0104BB



TECHNIC STANDARD
ANSI

TECHNIC SPEED
ANSI

Fully adjustable full body harness for rope access, work positioning and fall arrest with SPEED buckles, steel components, fall indicator and connector keepers.

- harness is certified to the latest American Standards ANSI Z359.11-2021 and NFPA 1983 Class III
- ergonomic and removable BIG/GIGA connector keepers on the shoulder straps allow you to store the fall arrest connectors when not in use. In case of a fall, the loops will release to allow the shock absorber can be safely deployed.
- for easy inspection, the harness is equipped with a fall indicator in the area of the back attachment point which is activated as a result of a fall, a red label indicates the harness must be retired
- front large attachment point for attaching descender or work positioning devices (EN 813, EN 358)
- steel side positioning points according to EN 358 with position adjustment are placed symmetrically and do not interfere at work
- front and rear attachment points for fall arrest (EN 361)
- attachment of the CAM CLEAN chest ascender by a mailon and the CAM CLEAN strap
- SPEED buckles allow smooth and quick donning and adjustment of the harness with maximum comfort
- the corrosion resistance of the steel components is tested by spraying in a salt chamber for 48 hours
- 2 braided gear loops with a bearing capacity of 5 kg
- additional slots on the waist belt allow you to safely hang expensive equipment

Size: S, M/L, XL

Weight: (M/L) 2085 g • 73.55 oz

Max. rated load: 150 kg (140 kg/310 lbs according ANSI)

ANSI Z359.11-2021 • NFPA 1983 Class III • CE 1019 • EN 358 • EN 813 • EN 361



WIND MASTER

W0112BY

NEW



Work harness that you can use not only for the maintenance of wind turbines. It is also suitable for work at height and service activities in telecommunications or the construction industry. WIND MASTER has a lot of features, but its main extras are the waist belt with the plastic back cover equipped with the durable glides and the front EN 361 LADDER CONNECTION POINT.

- harness is equipped with classic EN 361 front and rear attachment points for fall arrest; the rear point is recessed into the padding so it does not impede movement in confined spaces when not in use
- in addition, there is the specific EN 361 LADDER CONNECTION POINT on the front under the chest for connection to EN 353-1 fall arrest systems, which allows freer movement on secured ladders and structures
- if a fall is caught by the LADDER CONNECTION POINT, the auxiliary seams are ripped out and the point changes its position so that the user is not in danger of being turned head down
- wide waist belt with the plastic back cover equipped with the durable glides ensures comfortable movement and rest on fall arrest systems even in confined spaces
- shoulders have removable loops in the front for parking shock absorber hooks when they are not in use; under heavier loads, the loop is released so that a shock absorber can be safely deployed in the event of a fall
- upper parts of the shoulders have EN 1497 textile loops for pulling the user out in case of rescue from a confined space
- EN 813/EN 358 front attachment point located in the front serves for resting, lowering and work positioning
- additional work positioning options are offered by the two EN 358 swing-out attachment points on the sides of the waist belt
- SPEED buckles on the leg loops and at the waist ensure smooth and quick putting on of the harness, leaving more time for efficient work
- padding on the leg loops and shoulder straps evenly distributes the user's weight and thus reduces strain and fatigue
- waist belt is equipped with two standard textile loops with a load capacity of 5 kg, so the necessary equipment is always at hand
- steel buckles are E-coated for increased corrosion resistance in wet and salty environments
- using an additional carabiner, the CAM CLEAN chest ascender can be attached to the harness
- whether you're an experienced wind power technician or a newcomer to the industry, WIND MASTER guarantees you first-class comfort and functionality

Size: S, M/L, XL
 Weight: 2400 g (M/L) • 85 oz (M/L)
 Max. rated load: 150 kg
 CE 1019 • EN 358 • EN 813 • EN 361 • EN 1497



ROOF MASTER

W0091BY



You want freedom of movement when working on the roof, and the ROOF MASTER harness with its many features and unique Singing Rock MOTION SYSTEM guarantees it. Its movable attachment point is openable, which makes it easy to connect a chest ascender or detach the shoulder straps. So, you can choose between a full-body and a sit harness, it's up to you.

- Singing Rock MOTION SYSTEM guarantees freedom of movement without being restricted by a working rope or a fall arrest system
- in the front, part of the MOTION SYSTEM is the light alloy RINGO ring which forms a movable attachment point and a flexible connection between the waist belt and shoulder straps
- RINGO ring is openable, which allows easy attachment of the CAM CLEAN chest ascender or detachment of the shoulder straps and conversion of the full-body harness into the sit harness
- on the back of the harness, the MOTION SYSTEM consists of a classic light alloy ring that works as a flexible connection between the dorsal strap and the back of the waist belt
- this rear light alloy ring is equipped with a grey textile loop with a capacity of 100 kg for heavier work tools
- in the back of the shoulder straps there is a red EN 361 textile attachment point for fall arrest
- front EN 361 fall arrest point (the red light alloy D-ring) is positioned lower than usual and takes full advantages of the front part of the MOTION SYSTEM
- MOTION SYSTEM allows to use this point also for work positioning without restricting the user's movement or work - thus one point serves both for fall arrest and positioning at the same time
- red D-ring can also be used as EN 813 because it functions as an extension of the front attachment point
- SPEED buckles on the leg loops and on the left side of the waist belt ensure easy adjustment and comfortable putting on of the harness
- side textile EN 358 loops for work positioning are highlighted with red stitching and designed to prevent accidental catching during work
- 3D waist belt is equipped with a rubberized strength fabric with a number of attachment holes - you can thread an auxiliary cord through the holes to create additional loops or you can clip auxiliary carabiners into the holes to connect a tool bag (each hole has a bearing capacity of 10 kg)
- waist belt is also equipped with two standard textile loops with a bearing capacity of 5 kg
- ring-shaped leg loops are lightweight, yet very comfortable, their size can be easily adjusted with SPEED buckles, they are connected to the waist belt at the back by adjustable elastic straps
- neoprene pocket on the right leg loop is suitable for small items
- reflective printing on the waist belt increases the visibility of the harness
- identification label on the back of the shoulder straps ensures that you can always find yours in a pile of harnesses

Weight: (M/L) 1830 g • 64.55 oz

Max. rated load: 150 kg

Size: S, M/L, XL

CE 1019 • EN 358 • EN 813 • EN 361



TACTIC MASTER

W0096BB



Lightweight and fully adjustable fullbody safety harness intended mainly for special forces featuring the MOLLE system and a possibility to wear the harness above the bullet-proof vest. The unique Singing Rock MOTION SYSTEM with the openable RINGO O-ring gives the user freedom of movement without being restricted by a working rope or a fall arrest system. An ideal solution for working at heights where the precise positioning and free movement are important.

- frontal textile A point according to EN 361 is vertically adjustable, allowing to use the same harness with and without the bullet-proof vest
- abseil rope clipped through a connector, attached to A point, can help the user to stay in an upright position even with a heavy load on the back
- part of the EN 813 MOTION SYSTEM is the openable RINGO O-ring, which allows the user to disconnect the chest part and leg loops or put the chest ascender along with other devices directly to RINGO
- shoulder straps and leg loops are fully removable, the harness can be used as a sit harness or positioning (tactical) belt only
- textile loops for work positioning according to EN 358 designed in a way that prevents accidental capture during a work
- during the fall arrest to the dorsal textile attachment point EN 361, the MOTION SYSTEM efficiently splits the energy of the fall to the harness
- harness can be easily supplemented with the CAM CLEAN chest ascender
- shoulder connection for confined space rescue
- MOLLE system on the waist belt, leg loops and right shoulder strap to attach the pouch or other gear
- speed buckles for quick and easy put on/off
- rear light alloy ring is equipped with grey textile loop for heavier tools with a load capacity 100 kg



Size: S, M/L, XL
 Weight: (M/L) 1740 g • 61.38 oz
 Max. rated load: 150 kg
 CE 1019 • EN 358 • EN 813 • EN 361 • EN 1497



SEAMASTER 3D STAINLESS STEEL

W0074DR



Fully adjustable harness for rope access with a padded wide waist belt, leg loops and shoulder straps. Suitable for work positioning, fall arrest and work restraint situations.

This harness is specially intended for workers at offshore oil platforms.

- stainless steel components make the harness ultimate choice for offshore operations
- padded waist belt, shoulder straps and leg loops
- wide waist belt provides maximum comfort when working at height
- narrowed padding and webbing on the shoulder straps in a neck area enhance comfortable work
- reflective printing on the waist belt increases the visibility in dark working conditions
- front attachment point for fall-arrest according to EN 361
- front lower attachment point for descender placement or work positioning according to EN 813
- side attachment points for work positioning according to EN 358
- 3 braided gear loops with a bearing capacity of 5 kg

- heavier items up to 35 kg can be attached to the webbing on the waist belt
- additional loops with a bearing capacity of 5 kg offer additional space for the gear and better gear orientation
- combination of standard and SPEED buckles enable fluent and fast adjustment to fit the users body
- special construction of central loop provides excellent comfort when hanging in the harness
- easy fixing CAM CLEAN ascender in vertical position is provided by stitched strap between lower front attachment point and front tie-in point
- different color webbing stitched in the buckle simplifies adjusting and size selection

Weight: (M/L) 1870 g • 66 oz

Max. rated load: 150 kg

Size: S, M/L, XL

CE 1019 • EN 361 • EN 358 • EN 813



ANTISHOCK I

W0086B0



Full body harness for rope access, work positioning, fall arrest. The Antishock I is the perfect solution for work at height in explosive atmospheres. It is particularly suitable for energetics, petrochemical and mining environments.

- all metal and alloy parts are overmolded with colored plastic with an electrical puncture resistance of 10 kV and antistatic finishing
- harness certified according to the newest North American standards ANSI Z359.11-2014 and NFPA 1983 Class II
- ergonomic and removable lanyard keepers on the shoulder straps allow user to store lanyard connectors when not in use - in the event of a fall, the connector is released so that the shock absorber can be safely deployed
- for easier inspection, the harness is equipped with fall indicators placed close to dorsal attachment point which are activated in case of a fall - red label indicates that the harness must be retired
- shoulder attachment points for confined space rescue according to EN 14972

- side attachment points for work positioning according to EN 358
- front lower attachment point for descender placement or work positioning according to EN 813
- narrowed padding and webbing on the shoulder straps in a neck area enhance a comfortable work
- chest ascender smart fixation system
- chest ascender maillon slot (recommended maillon big D, EN 362)
- 2 large braided gear loops with a bearing capacity of 5 kg
- name tag for easier recognition of the harness

Size: S, M/L, XL

Weight: (M/L) 2430 g • 85.72 oz

Max. rated load: 150 kg (140 kg/310 lbs according to ANSI)

ANSI Z359.11-2014 • NFPA 1983 Class III • CE 1019 • EN 358 • EN 813 • EN 361 • EN 1497



TARZAN ECONOMIC

W0059BR

Fully adjustable full body harness intended for rope courses and adventure parks.

- front attachment point for belaying and rappelling according to EN 12277 type C
- waist belt and leg loops without the padding enables to put a harness to every person
- rear steel D-ring with a bearing capacity of 15 kN according EN 361
- shoulder straps, waist belt and leg loops are easily adjustable with Easy Lock buckles
- all steel components are finished with E coating technology for higher corrosion resistance
- left leg loop with red colour helps to put the harness on
- webbing strap stitched in the buckle simplify handling with a buckle
- dorsal plastic plate with different color according the size of the harness (S – yellow, UNI – red)

Size: S (110 – 150 cm), UNI (150 – 200 cm)

Weight: 1050 g • 34 oz (UNI)

€1019 • EN 12277 • EN 361



ROPEDANCER II

W008/BY

Fully adjustable full body harness with various attachment points intended for rope courses and adventure parks

- easy to put on and off,
- easy to adjust, thanks to 5 double buckles and 1 SPEED buckle
- bright color front lower attachment point for rappelling and belaying • waist belt in different (black) color for better orientation within the harness
- front and rear attachment points
- 2 gear loops with a bearing capacity of 5 kg
- max. rated load of the harness 150 kg
- different color of the rear triangle for each size
- suitable also for working at height

Weight: (S/M/L) 1195 g • 42.15 oz

€1019 • EN 12277



BODY II STANDARD

W0068BR
black version – W0068BB**Fully adjustable fall-arrest harness with various attachment points.**

- two fall-arrest attachment points according to EN 361
- harness is compact and light-weight, thus suitable for horizontal or inclined space. It also allows temporary hanging in.
- intended for working in places with the risk of fall
- flat rear attachment point does not affect comfort when wearing the backpack or breathing apparatus
- shoulder and leg loops webbings are colour distinguished for easy manipulation
- webbing stitched in the buckle simplify handling
- two gear loops with max. load 5 kg
- easy to adjust, easy to put on and off
- suitable also for rope courses and adventure parks
- different colour of rear triangle for each size (S/M/L- grey, XL/XXL- yellow)
- 2 sizes fit whole size range from 150 to 210 cm

Size: S/M/L, XL/XXL, XXXL
Weight: 1025 g • 36.16 oz (size S/M/L)
CE 1019 • EN 361

BODY II SPEED

W0071BY
black version – W0071BB**Fully adjustable fall-arrest harness with various attachment points.**

- version with Speed buckles on the leg loops enables easy putting the harness on
- easy to adjust, easy to put on and off
- webbing stitched in the buckle simplify handling

Size: S/M/L, XL/XXL, XXXL
Weight: 1185 g • 41.8 oz (size S/M/L)
CE 1019 • EN 361

BODY II ENERGY SPEED

W0093SY



Fully adjustable work-positioning harness with various attachment points, speed buckles and comfortable padding.

- suitable for working situations with maximum freedom of movement during work positioning
- stitched waist belt padding allows horizontal or vertical movement of the padding thus providing maximum comfort during a work.
- side attachment points for work positioning according EN 358
- front and rear attachment points according EN 361 marked with „A“ label
- removable and washable shoulder and leg loops padding provides great comfort
- shoulder padding with reflective straps and integrated loops for hooks storage
- webbing stitched in the buckles simplify handling
- two gear loops with max. load 5 kg
- 4 additional plastic hooks for light gear attachment
- 3 sizes fit whole size range from 150 to 210 cm

Size: S/M/L, XL/XXL, XXXL
Weight: 2250 g • 79.44 oz (size S/M/L)
€ 1019 • EN 361 • EN 358



Power cable installation at cableway Zugspitze, Germany • Gábor Berta

BASIC LIGHT

W0090SY

Fully adjustable fall-arrest harness with a rear dorsal attachment point.

- dorsal rear D-ring attachment point according to EN 361
- one gear loop with max load of 5 kg
- easy to adjust thanks to 4 easy-lock buckles, easy to put on and off
- different color of the rear webbing for each size (S/M/L grey, XL/XXL yellow)
- all steel components finished with E-coating for higher corrosion resistance
- 2 sizes fit whole size range from 150 to 210 cm
- suitable for use with a range of accessories like Pole, Harness Padding, Suspension Trauma Safety Strap

Size: S/M/L, XL/XXL
 Weight: 760 g • 26.81 oz / 810 g • 28.5 oz
 €1019 • EN 361



BASIC

W0089SY

Fully adjustable fall-arrest harness with rear dorsal and front sternum attachment points.





- dorsal rear D-ring and front textile twin loops attachment points according to EN 361
- one gear loop with max load of 5 kg
- easy to adjust thanks to 4 easy-lock buckles, easy to put on and off
- different color of the rear webbing for each size (S/M/L grey, XL/XXL yellow)
- all steel components finished with E-coating for higher corrosion resistance
- 2 sizes fit whole size range from 150 to 210 cm
- suitable for use with a range of accessories like Pole, Harness Padding, Suspension Trauma Safety Strap

Size: S/M/L, XL/XXL
 Weight: 820 g • 29 oz / 885 g • 31 oz
 €1019 • EN 361



FAVORABLE COMBINATIONS

Singing Rock also offers favorable combinations of the fall-arrest harnesses and range of accessories:

Harness / Accessory	w/ Padding	w/Pole II	w/ Padding and Pole II
 <p>Basic Light</p>	M0023DX	M0023PX	M0023XX
 <p>Basic</p>	M0024DX	M0024PX	M0024PX
 <p>Body II standard</p>	M0025DX	M0025PX	M0025XX
 <p>Body II speed</p>	M0026DX	M0026PX	M0026XX

POLE II

W0073



Belt for work positioning and prevention against the falls from a height.

- anatomic padded waist belt ensures minimal bruising and enough comfort in the waist area
- two side "D" ring for work positioning according to EN 358, tested for 15 kN strength
- two braided gear loops with a bearing capacity of 5 kg
- slots designed for a secure hanging of expensive equipment (such as power saw, drilling machine,...) with a capacity of 1 kN
- speed buckles allow easy manipulation when dressing up and undressing

Recommended use:

- for work positioning and prevention of falls from a height
- possible combination with fullbody fall-arrest harness BODY II

Size: S/M/L, XL/XXL, XXXL
 Weight: (S/M/L) 575 g • 20.3 oz
 € 1019 • EN 358



HARNESS PADDING

W0092BB



Removable shoulder and leg padding intended for Body II, Basic and Basic Light harnesses.

- durable and soft material spreads the tension to a bigger surface to increase the comfort of wearing the harness
- reduces the effects of suspension trauma after a fall
- integrated loops on shoulder padding for hooks storage
- removable and washable padding

Size: S/M/L, XL/XXL
Weight: 236 g • 8.33 oz (S/M/L)



TECHNIC PADDING

W0097BB00



Removable shoulder padding for TECHNIC harnesses

- durable and soft material spreads the tension to a bigger surface to increase the comfort of wearing the harness
- integrated loops for hooks storage
- removable and washable

Size: UNI
Weight: 100 g (3.5 oz)



CONNECTION STRAP

W2020X080



Extremely light and durable sling intended mainly for connection between rear dorsal attachment point and self-retractable lifelines.

- allows an easy self-connection to the rear EN 361 D-ring
- made out of dyneema
- 15 cm and 5 cm long loops are on both ends of a sling
- big loop is overturned to make a Girth Hitch knot over a D ring

Length: 80 cm
Width: 13 mm
Weight: 40 g • 1.41 oz
CE 1019 • EN 354



REFLECT VEST

W9804YX



Fluorescent-colored vest with reflective strips certified according to EN ISO 20471:2013. Suitable for all Singing Rock fall arrest harnesses with or without padding which can also be equipped with the Pole II positioning belt.

- Öko-Tex® certified 240 g/m² fabrics made of PES and cotton combination for improved comfort of the user
- stitched retroreflective stripes with microscopic glass beads
- reinforced holes with hook-and-loop fixation of straps, positioning attachment points and gear loops
- size adjustment system using hook-and-loop fixation on a flap
- fits to Basic Light, Basic, Body II, Body II Energy harnesses with or without attached padding and the Pole II positioning belt
- fulfils the requirements of EN ISO 13688:2013 Protective clothing and EN ISO 20471:2013 High visibility clothing

- Material: cotton, PES, glassWeight: 375g
 - 13.23 ozSize: S/M/L, XL/XXL, XXXL
- EN ISO 20471:2013 · EN ISO 13688:2013



HOOK PARKING LOOP

W0102YB00



Removable connector keepers for accommodating shock absorber lanyards on shoulder straps of a full-body harness.

- in case of a fall, a parked connector is released so that a shock absorber can be safely deployed
- suitable for most of Singing Rock full-body harnesses
- marking according to ANSI Z359.11-2014
- loop is reinforced with a plastic cover
- attachment using velcro
- sold as 2 pcs.

Weight: 14 g • 0.5 oz (a piece)



SUSPENSION TRAUMA SAFETY STRAP

W1029BX00



Auxiliary sling preventing effects of suspension trauma after a fall.

- helps to relieve pressure in the groin area while a worker is awaiting rescue
- easy to attach to a harness using a girth hitch and velcro strap
- plastic cover increases resistance during normal working activities
- patented Rock&Lock buckle ensures easy length adjustment
- colored stepping loop
- suitable for Body II, Basic and Basic Light harnesses

Weight: 63 g • 2.2 oz
Material: polyamide



SIT WORKER 3D / SPEED

W0076DR
black version – W0076DB



Fully adjustable sit harness for work positioning. The new design of this sit harness is characterized by perfect functionality, great comfort and lightness. Intended for all vertical activities without any risk of the fall.

- super comfortable wide waist belt padding provides maximum comfort when working at height
- strength webbing on the waist belt is stitched in the way that at normal working situation the body weight is absorbed by the padding only
- anatomic leg loops and waist belt are covered with strong PES fabric providing high abrasion resistance
- SPEED buckles enable fluent and fast adjustment to fit a user's body
- side attachment points for work positioning according to EN 358
- front attachment point for descender placement or work positioning according to EN 813, EN 358

- reflective strap and printing on the waist belt increase the visibility in dark working conditions
- 4 ergonomic braided gear loops with a bearing capacity 15 kg
- additional loops on the waist belt and leg loops with a bearing capacity of 5 kg offer additional space for the gear and better gear orientation
- slots on the waist belt for PORTER tool holder to carry your industrial tools

Size: S, M/L, XL
Weight: (M/L) 1515 g • 53.44 oz
Max. rated load: 150 kg
€ 1019 • EN 358 • EN 813



SIT WORKER 3D / STANDARD

W0075DR
black version – W0075DB



Fully adjustable sit harness with easy-lock buckles for work positioning.

- thermo finished webbing in a waist belt for easy handling and higher durability
- all steel components finished with E coating for higher corrosion resistance
- super comfortable wide waist belt padding provides maximum comfort when working at height
- side attachment points for work positioning according to EN 358

Size: S, M/L, XL
Weight: (M/L) 1195 g • 42.15 oz
Max. rated load: 150 kg
€ 1019 • EN 358 • EN 813



URBAN II

W0022BB

**Sit harness for work positioning**

- anatomic waist belt and leg loops padding perfectly fits to man anatomy
- textile attachment point for work in hanging position, rappelling according to EN 813.
- textile positioning points according to EN 358 are placed symmetrically, tested for 15 kN strength.
- 2 braided gear loops with a bearing capacity of 10 kg provide enough space for 10 pieces of HMS carabiners
- additional loops with a bearing capacity of 5 kg offer additional space for the gear and better gear orientation
- slots designed for a secure hanging of expensive equipment (such as power saw, drilling machine,..)

Size: S, M/L, XL

Weight: M/L 850 g (±15g) • 30 oz

Max. rated load: 150 kg

CE 1019 • EN 358 • EN 813



FRANKLIN

W0010YB
black version – W0010BB**Work positioning seat provides more comfort when hanging in the harness.**

- intended for use with our fall arrest or work positioning harnesses
- easy to adjust with Rock&lock buckles. Attachment straps are shorter to fit better to thinner users
- inside padding is made of aluminium which allows long term use without any deformation
- wider sitting area ensures good stability and allows comfortable suspension as well as standing at work positioning
- suspension straps do not press on your thighs

- three D-rings (bearing capacity 50 kg) for bucket or other gear suspension

Max. load of seat: 150 kg

Weight: 1615 g • 57 oz



ALADIN

C5056

**Chest harness**

- designed to be used together with a sit harness
- optimising body position while hanging or falling
- made from lightweight wide nylon webbing
- very durable and affordable to all climbers

Must be worn with sit harness.
Do not use chest harness alone!

Size: UNI
Weight: 240 g • 8.5 oz
CE 1019 • EN 12277 • 



RL CHEST

W0200BB

**Fully adjustable chest harness**

- non-padded
- Rock&Lock buckles on shoulder straps
- two D-rings with bearing capacity of 50 kg
- together with SIT WORKER 3D compose fully adjustable full body harness in conformity with EN 361

Do not use separately - use only in combination with a sit harness!

Size: UNI
Weight: 600 g • 21.2 oz
CE 1019

ARBO CHEST

W0108BR00

**Padded chest harness designed for the ARBO MASTER arborist harness.**

- offers the user greater comfort when loading the harness with heavier equipment and a more comfortable ascent
- for comfortable donning, equipped with a trident with a whistle at the front
- in the shoulder padding, there is a tunnel on each side for threading a pull-on elastic band, which is specially designed for SRT technique
- loops on the front side for possible attachment of additional equipment and height adjustment for attaching a chest ascender

- the chest harness can be used with any harness equipped with three fixing eyes

The chest harness cannot be used alone!

Size: UNI
Material: PAD, EVA foam, PES, Polyethylene, PP, Elastane
Weight: 160 g / 5.6 oz

ARBO MASTER

W0105BR



Fully adjustable work positioning harness with unique motion system at front attachment points, specially invented for professional arborists allowing freedom of movement at the tree top.

- super comfortable wide waist belt made of 3 inside webbings and wide leg loops made of 2 inside webbings provide maximum comfort when working in the harness
- removable and exchangeable bridge connecting the leg loops for variability of work at the tree top
- double rope connection bridge for two independent attachment points (EN 813) with a strength 15 kN
- knots on the connection bridge allow the length adjustment and replacement
- moveable O ring at the connection bridge as an attachment point (EN 813)
- adjustable red side D buckles between the leg loops and waist belt for the attachment point, used in a pair according to EN 813 with a strength 15 kN
- adjustable side positioning D rings possible to fold in when not in use
- replaceable adjusting webbing for D rings
- speed buckles enable fluent and fast adjustment of the waist belt and the leg loops, keep the adjusted size
- flexible rear rubber bands for adjusting the position of the leg loops
- 4 gear loops with a bearing capacity of 5 kg provide enough space for your gear
- rear loop for hanging heavy tools such as a chainsaw, etc. with a load capacity of 35 kg
- 2 red textile loops with a load capacity of 5 kg for attaching a hand saw
- 2 small steel rings with a load capacity of 10 kg for attaching the chainsaw on the left and right side
- small textile loops to create your own additional gear loops with a load capacity of 5 kg
- loops at the waist belt for the possibility of attaching a chest harness

- slots for PORTER tool holder to carry your industrial tools
- wide rubber band for attaching the first aid kit to the harness
- neoprene pocket on the leg loop for small items
- identification and methodological label

Size: S/M/L, XL

Max. rated load: 120 kg

Weight: 1680 g • 59.3 oz (S/M/L), 1760 g

• 62 oz (XL)

CE 1019 • EN 358 • EN 813

SPARE PARTS:

W0109RX00 ARBO MASTER BRIDGE

W0110RX00 ARBO MASTER ADJUSTABLE WEBBING





EVACUATION TRIANGLE SIT II

W8201BY00



Evacuation triangle for a person to rescue from a chair lift or a cable car.

- chest plastic buckle for easy putting on the triangle
- durable steel attachment points
- easy to put on and take off
- adjustable crotch webbing
- made from durable ripstop material

Only for rescue purposes.

Size: UNI • Weight: 800 g • 1.8 lb
EN 1498



EVACUATION TRIANGLE COMBI II

W8211BY00



Evacuation triangle with shoulder straps for a person to rescue from a chair lift or a cable car.

- special shoulder straps for better fixing a person in evacuation triangle
- straps are made from different color for better attachment management
- durable steel attachment points
- easy to put on and take off
- adjustable crotch webbing
- made from durable ripstop material

Only for rescue purposes.

Size: UNI • Weight: 880 g • 1.9 lb
CE 1019 • EN 1497 • EN 1498



LAIKA

W0005YB09
black version – W0005BB09



Dog harness intended for transport of the dog from a helicopter.

- side light-alloy reinforcements
- easy and quick fastening with velcro
- max. load 150 kg

Size: UNI • Weight: 800 g • 1.8 lb



BABY RESCUE BAG

W8220



Rescue bag for the children evacuation.

- designed for rescue transporting of the children (height 40-110 cm, max. weight 25 kg)
- safety fixation by 3 belts with Velcro and with the safety straps led to cross during the transporting.
- inner padding is very comfortable and fully removable and washable
- top cover with full zipper and ventilation hole
- stabilization strap of the top cover to prevent the camber of the cover to the face of the child during the transport by the helicopter
- colored loops for the carabiner fixation and adjusting the position of the bag
- side ventilation holes covered by PVC net
- durable material with the reflection elements
- hygienic inner textile cover included
- fulfils EN 1498 requirements

Size: 80x45x35 cm

Weight: 3300 g

Max. load: 25 kg

Material:

PVC, PAD, PES,
PES / cotton







CE









Chair lift evacuation, Janské Lázně, Czechia •  Ondřej Vitko





	type	black version	code	size	weight M/L [g]	waist [cm/in]	leg loops [cm/in]	height [cm]
	standard	✓	W0078DR02	S	2110	65-80 / 25-31	45-60 / 18-24	150-170
		✓	W0078DR03	M/L		75-100 / 29-39	50-75 / 19-29	160-180
		✓	W0078DR05	XL		85-130 / 33-51	50-75 / 19-29	175-205
	speed	✓	W0079DR02	S	2415	65-80 / 25-31	45-60 / 18-24	150-170
		✓	W0079DR03	M/L		75-100 / 29-39	50-75 / 19-29	160-180
		✓	W0079DR05	XL		85-130 / 33-51	50-75 / 19-29	175-205
	speed steel	✗	W0080DR02	S	2685	65-80 / 25-31	45-60 / 18-24	150-170
		✗	W0080DR03	M/L		75-100 / 29-39	50-75 / 19-29	160-180
		✗	W0080DR05	XL		85-130 / 33-51	50-75 / 19-29	175-205
	speed	✓	W0081DR02	S	1777	65-80 / 25-31	45-60 / 18-24	150-170
		✓	W0081DR03	M/L		75-100 / 29-39	50-75 / 19-29	160-180
		✓	W0081DR05	XL		85-130 / 33-51	50-75 / 19-29	175-205
	standard	✓	W0082DR02	S	2075	65-80 / 25-31	45-60 / 18-24	150-170
		✓	W0082DR03	M/L		75-100 / 29-39	50-75 / 19-29	160-180
		✓	W0082DR05	XL		85-130 / 33-51	50-75 / 19-29	175-205
	standard	✗	W0063BB02	S	1725	65-80 / 25-31	45-60 / 18-24	150-170
		✗	W0063BB03	M/L		75-100 / 29-39	50-75 / 20-29	160-180
		✗	W0063BB05	XL		85-130 / 33-51	50-75 / 20-29	175-205
	speed	✗	W0064BB02	S	2045	65-80 / 25-31	45-60 / 18-24	150-170
		✗	W0064BB03	M/L		75-100 / 29-39	50-75 / 20-29	160-180
		✗	W0064BB05	XL		85-130 / 33-51	50-75 / 20-29	175-205
	standard	✗	W0103BB02	S	1805	65-80 / 25-31	45-60 / 18-24	150-170
		✗	W0103BB03	M/L		75-100 / 29-39	50-75 / 20-29	160-180
		✗	W0103BB05	XL		85-130 / 33-51	50-75 / 20-29	175-205
	speed	✗	W0104BB02	S	2085	65-80 / 25-31	45-60 / 18-24	150-170
		✗	W0104BB03	M/L		75-100 / 29-39	50-75 / 20-29	160-180
		✗	W0104BB05	XL		85-130 / 33-51	50-75 / 20-29	175-205
		✗	W0112BY02	S	2400	65-80 / 25-31	45-60 / 18-24	150-170
		✗	W0112BY03	M/L		75-100 / 29-39	50-75 / 20-29	160-180
		✗	W0112BY05	XL		85-130 / 33-51	50-75 / 20-29	175-205
		✗	W0091BY02	S	1570	65-80 / 25-31	45-60 / 18-24	150-170
		✗	W0091BY03	M/L		75-100 / 29-39	50-75 / 19-29	160-180
		✗	W0091BY03	XL		85-130 / 33-51	50-75 / 19-29	175-205



	type	black version	code	size	weight M/L [g]	waist [cm/in]	leg loops [cm/in]	height [cm]	
TACTIC MASTER 		✓	W0096BB02	S	1740	70-85 / 27-33	45-60 / 18-24	150-170	
		✓	W0096BB03	M/L		80-100 / 31-39	50-75 / 20-29	160-180	
		✓	W0096BB05	XL		90-130 / 35-51	50-75 / 20-29	175-205	
SEAMASTER 3D 		×	W0074DR03	S	1870	65-80 / 25-31	45-60 / 18-24	150-170	
		×	W0074DR03	M/L		75-100 / 29-39	50-75 / 19-29	160-180	
		×	W0074DR05	XL		85-130 / 33-51	50-75 / 19-29	175-205	
ANTISHOCK I 	standard	×	W0086B002	S	2430	65-80 / 25-31	45-60 / 18-24	150-170	
		×	W0086B003	M/L		75-100 / 29-39	50-75 / 20-29	160-180	
		×	W0086B005	XL		85-130 / 33-51	50-75 / 20-29	175-205	
TARZAN ECONOMIC 			W0059BR	UNI	1050	UNI	59-78	150-200	
				S			43-78	110-150	
ROPEDANCER II 				XS	1195		UNI	125-155	
				S/M/L			65-100 / 25-39	UNI	150-185
				XL/XXL			85-155 / 33-61	UNI	180-210
BODY II 	standard	✓	W0068BR03	S/M/L	1025		UNI	45-70 / 18-27	150-185
		✓	W0068BR05	XL/XXL			UNI	45-85 / 18-33	180-210
		✓	W0068BR07	XXXL			UNI	45-95 / 18-39	180-210
	speed	✓	W0071BR03	S/M/L	1185		UNI	45-70 / 18-27	150-185
		✓	W0071BR05	XL/XXL			UNI	45-85 / 18-33	180-210
		✓	W0071R07	XXXL			UNI	45-95 / 18-39	180-210

	type	black version	code	size	weight M/L [g]	waist [cm/in]	leg loops [cm/in]	height [cm]
BODY II ENERGY SPEED 	speed	×	W0093SY	S/M/L	2250	75-125 / 29-49	55-70 / 22-28	150-185
		×		XL/XXL		85-140 / 33-55	65-90 / 25-35	180-210
				XXXL		85-155 / 33-61	65-105 / 25-41	180-210
BASIC 		×	W0089SY02	S/M/L	820	UNI	45-70 / 18-27	150-185
		×	W0089SY05	XL/XXL		UNI	45-85 / 18-33	180-210
BASIC LIGHT 		×	W0090SY02	S/M/L	760	UNI	45-70/18-27	150-185
		×	W0080SY05	XL/XXL		UNI	45-85/18-33	180-210
POLE II 		✓	W0073BY02	S/M/L	575	75-100 / 29-39		
		✓	W0073BY03	XL/XXL		85-130 / 33-51		
		✓	W0073BY05	XXXL		95-150 / 37-59		
SIT WORKER 3D 	standard	✓	W0075DR02	S	1195	65-80 / 25-31	45-60 / 18-24	
		✓	W0075DR03	M/L		75-100 / 29-39	50-75 / 19-29	
		✓	W0075DR05	XL		85-130 / 33-51	50-75 / 19-29	
	speed	✓	W0076DR02	S	1515	65-80 / 25-31	45-60 / 18-24	
		✓	W0076DR03	M/L		75-100 / 29-39	50-75 / 19-29	
		✓	W0076DR05	XL		85-130 / 33-51	50-75 / 19-29	
URBAN II 	standard	✓	W0022BB02	S	850	65-80 / 25-31	45-60 / 18-24	
		✓	W0022BB03	M/L		75-100 / 29-39	50-75 / 19-29	
		✓	W0022BB05	XL		85-130 / 33-51	50-75 / 19-29	



type	black version	code	size	weight M/L [g]	waist [cm/in]	leg loops [cm/in]	height [cm]
ALADIN 	✓	C5056	UNI	240			
RL CHEST 	✓	W0200BB	UNI			chest max. 125 / 49	
ARBO CHEST 	×	W0108BR00	UNI	160			150-210
ARBO MASTER 	×	W0105BR02	S/M/L	1680	65-100 / 25-39	45-65 / 18-25	
	speed	×	W0105BR05	XL	1760	85-130 / 33-51	





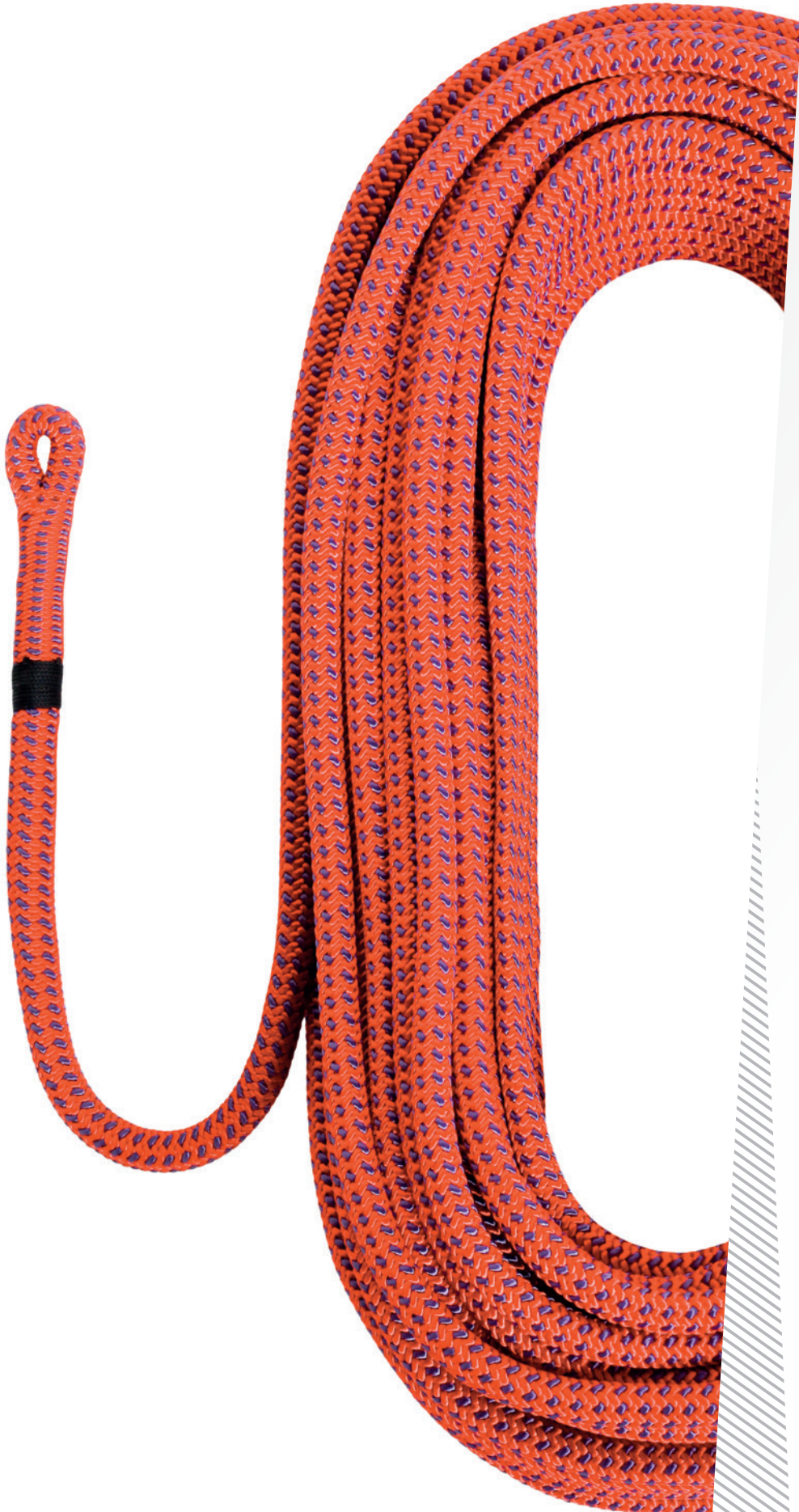

ROPES

STATIC
DYNAMIC
SPECIAL
SPELEO
CORDS
ACCESSORIES





ROUTE 44

experience the touch of the future

Route 44 is unique technology invented and patented by Singing Rock. Route 44 technology allows blending of properties that were considered impossible before. Rope braided by using Route 44 technology is more compact, softer and above all it is more durable than conventional rope. All that is achieved by making no compromises in using correct sheath thickness, which is round-braided by 44 carriers. These features combine to give you better rope.



ULTRASONIC

ULTRASONIC ending is an excellent way of rope ending.

All SINGING ROCK ropes are ended by a unique technology ULTRASONIC. The load-bearing core and the protective sheath are joined into a compact unit in the last 15 mm of the rope which eliminates the sheath slippage.

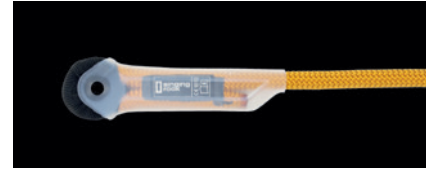

STITCHED EYE

Selected SINGING ROCK static ropes which are marked with Stitched eye icon are possible to produce with one or two stitched eyes at the end of the rope.

STATIC R44 11.0



L0450WG – white
L0450RR – red



L0450BB – black
L0450OO – orange



Excellent quality static rope intended for rope access, work positioning, rescue or manipulation with the objects.

- type A rope – low stretch kernmantel rope designed for general use with patented rope-braiding technology ROUTE 44
- sheath is made on 44 carrier machine thus the core/sheath ratio is ideal with reference to the strength of the rope and strength of the rope with knots
- sheath is braided more densely which provides better protection of the core against dirt and dust
- rope is running smoother through belay / rappel devices with lower risk of core prolapse through the sheath when is bent over small diameters

- meets the requirements that the rescuers, firemen, specialists working at height and other professionals require when working every day
- ultrasonic ending eliminates the sheath slippage
- possible to be produced with one or two stitched eyes at the end of the rope

Weight: 77 g/m
Strength: 34.9 kN
Diameter: 11.0 mm
Length: pack: 30, 40, 50, 60, 70, 80, 100 m
spool: 100, 200 m
€€ 1019 • EN 1891 •  

STATIC R44 10.5



L0430WR – white
L0430RR – red

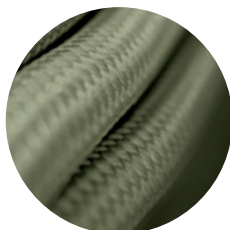

L0430BB – black
L0430KK – khaki



Low stretch kernmantel rope type A designed for general use with patented rope-braiding technology ROUTE 44

- intended for rope access, work positioning, rescue or manipulation with the objects
- sheath is made on 44 carrier machine thus the core/sheath ratio is ideal with reference to the strength of the rope and strength of the rope with knots
- sheath is braided more densely which provides better protection of the core against dirt and dust
- rope is running smoother through belay / rappel devices with lower risk of core prolapse through the sheath when is bent over small diameters

- ultrasonic ending eliminates the sheath slippage
- possible to be produced with one or two stitched eyes at the end of the rope

Weight: 72 g/m
Strength: 31.5 kN
Diameter: 10.5 mm
Length: pack: 30, 40, 50, 60, 70, 80, 100 m
spool: 100, 200 m
€€ 1019 • EN 1891 •  

STATIC 11.0 

L0250WR – white
L0250RR – red
L0250BB – black

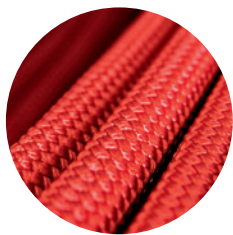

Static rope for workers at height, rescuers, firemen, cavers and other professionals when working every day.

- low stretch kernmantel rope type A intended for rope access, work positioning, rescue, caving or manipulation with the objects
- ultrasonic ending eliminates the sheath slippage
- possible to be produced with one or two stitched eyes at the end of the rope
- available in 3 colors

Color: white, red, black
Weight: 80 g/m
Strength: 34.5 kN
Diameter: 11 mm
Length: pack: 30, 40, 50, 60, 70, 80, 100 m
spool: 100, 200 m
CE 1019 • EN 1891 • 

STATIC 10.5 

L0230WR – white
L0230RR – red
L0230BB – black
L0230KK – khaki

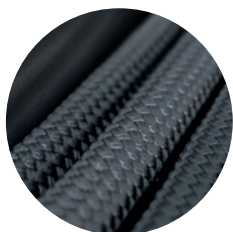

Low stretch kernmantel rope type A intended for rope access, work positioning, rescue, caving or manipulation with the objects.

- meets the requirements that the rescuers, firemen, specialists working at height and other professionals require when working every day
- ultrasonic ending eliminates the sheath slippage
- possible to be produced with one or two stitched eyes at the end of the rope
- available in 4 colors

Color: white, red, black, khaki
Weight: 77 g/m
Strength: 30.4 kN
Diameter: 10.5 mm
Length: pack: 30, 40, 50, 60, 70, 80, 100 m
spool: 100, 200 m
CE 1019 • EN 1891 • 



STATIC R44 NFPA 10.5



black – R0430BB
khaki – R0430KK

red – R0430RR
white – R0430WR



Excellent static rope designed for technical use for rope access, rescue and for manipulation with the objects. Meet NFPA 1983 Technical Use requirements that the rescuers, firemen, specialists working at height and other professionals require when working every day.

Weight: 72 g/m • Strength: 32 kN
Length: pack: 150, 200, 300 ft / 46, 61, 92 m
spool: 330, 600, 660 ft / 100, 183, 200 m
Diameter: 10.5 mm

Static elongation: 3.5% (at 3.5 kN, 300 lbs)
7.2% (at 2.7 kN, 600 lbs) • 9.9% (at 4.4 kN, 1000 lbs)
NFPA 1983 Technical Use • EN 1891 • CE 1019
• EN 1891 •

STATIC R44 NFPA 11.0 (7/16")



black – R0450BB
orange – R0450OO

red – R0450RR
white – R0450WG



Excellent static rope, meet NFPA 1983 Technical Use requirements that the rescuers, firemen, specialists working at height and other professionals require when working every day. Manufactured by patented rope-braiding technology ROUTE 44 with ultrasonic ending.

Weight: 77 g/m • Strength: 33.5 kN
Length: pack: 150, 200, 300 ft / 46, 61, 92 m
spool: 330, 600, 660 ft / 100, 183, 200 m
Diameter: 11.0 mm • 7/16 in

Static elongation 3.0% (at 1.35 kN, 300 lbs)
6.8% (at 2.7 kN, 600 lbs)
10.8% (at 4.4 kN, 1000 lbs)
NFPA 1983 Technical Use • EN 1891
• CE 1019 •

STATIC R44 NFPA 13.0 (1/2")



R0460WB



Excellent static rope for everyday work at height designed for general use for rope access, rescue and for manipulation with the objects. Meet NFPA 1983 General Use requirements.

Weight: 108.7 g/m
Strength: 47 kN
Length: pack: 150, 200, 300 ft / 46, 61, 92 m
spool: 330, 600, 660 ft / 100, 183, 200 m

Diameter: 13.0 mm • 1/2 in

Static elongation: 3.4% (at 1.35 kN, 300 lbs)
5.4% (at 2.7 kN, 600 lbs)
7.6% (at 4.4 kN, 1000 lbs)
NFPA 1983 General Use

STATIC 9.0

L0220WR – white
L0220BB – black

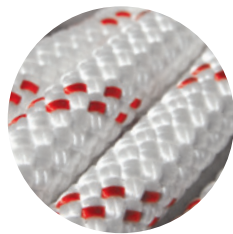

Static rope type B. Low stretch kernmantel rope of a lower performance than type A ropes, requiring greater care in use.

- smaller diameter provides easier handling and lower weight
- recommended use: back-up rope, hauling and lowering, expeditions
- ultrasonic ending eliminates the sheath slippage
- available in 2 colors

Color: white, black
Weight: 54 g/m
Strength: 24.4 kN
Diameter: 9 mm
Length: pack: 30, 40, 50, 60, 70, 80, 100 m
spool: 100, 200 m
CE 1019 • EN 1891 •

CONTRA 10.5

L026

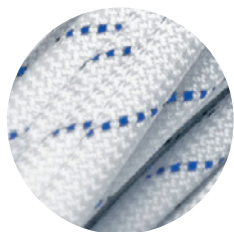

All-purpose static rope providing a balance between flexibility and abrasion resistance.

- intended for rope access, work positioning, rescue or manipulation with the objects
- ultrasonic ending eliminates the sheath slippage
- white color makes the rope easy to spot in the dark conditions

Color: white
 Weight: 69 g/m
 Strength: 30 kN
 Diameter: 10.5 mm
 Length: pack: 30, 40, 50, 60, 70, 80, 100 m
 spool: 100, 200 m
 CE 1019 • EN 1891 • 

TILIA 11.5

L0460OV00
 spliced loop - L04680



Static rope specially invented for professional tree care operations.

- sheath construction guarantees higher abrasion resistance and longer lifetime
- rope has high static strength and low elongation which provides efficient work at the tree top
- works perfectly with the friction knots as well with mechanical devices
- small diameter ensures very good performance in terms of flexibility and weight

- available with a splice at one end for optimal rope glide through devices like a cambium saver or pulley

Diameter: 11.5 mm • Weight: 90 g/m
 Number of falls: 20 • Strength: 30 kN
 Min. strength with a knot: 18 kN
 Percentage of sheath: 54 %
 Sheath slippage: 0.5% • Static elongation: 3%
 Shrinkage: 1% Material: PES/PA
 CE 1019 • EN 1891

SPELEO R44 10.5



L0440WR

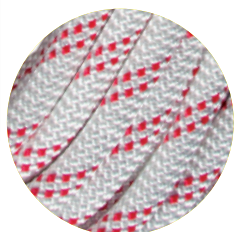

Static rope with patented rope-braiding technology ROUTE 44 developed especially for cave exploring.

- sheath is made on 44 carrier machine thus the core/sheath ratio is ideal with reference to the strength of the rope and strength of the rope with knots
- rope is running smoother through belay/ rappel devices with lower risk of core prolapse through the sheath when is bent over small diameters
- white color makes the rope easy to spot in the dark

- ultrasonic ending eliminates the sheath slippage

Color: white
 Weight: 72 g/m
 Strength: 33.4 kN
 Diameter: 10.5 mm
 Length: pack: 30, 40, 50, 60, 70, 80, 100 m
 spool: 100, 200 m
 CE 1019 • EN 1891 • 

SPELEO

L0240WR



Static rope developed especially for cave explorers.

- all-purpose rope providing a balance between flexibility and abrasion resistance that is ideal for your explorations
- great rope for wet and muddy conditions
- white color makes the rope easy to spot in the dark
- ultrasonic ending eliminates the sheath slippage

Color: white
 Weight: 71 g/m
 Strength: 29.4 kN
 Diameter: 10.5 mm
 Length: pack: 30, 40, 50, 60, 70, 80, 100 m
 spool: 100, 200 m
 CE 1019 • EN 1891 • 

DNA DRY 8.9



L3060CX

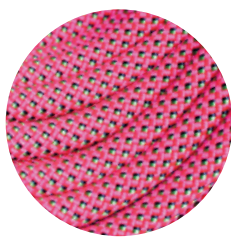

One rope for all your climbing activities. Suitable for sport climbing at the top level and also for mountaineering and glacier tours thanks to its lightness and water resistance.

- certificated as a single, twin and half rope for the widest range of use
- extremely lightweight, ideal rope for onsight, flash or redpointing your climbing projects where every small detail matters
- great rope for mountaineering, glacier tours or trad climbing

- rope is soft and easy to manipulate in all belay devices
- UIAA water repellent treatment achieved by revolutionary nanotechnology, this treatment gives the rope longer lifetime and water resistance
- thermotransfer end marking
- middle marking
- ultrasonic ending

CE 1019 • EN 892 • UIAA • ① 1/2 ∞

ICON DRY 9.3



L0384RX



Excellent single rope for high-level climbers or glacier/mountain usage thanks to its lightness and water resistance.

- extremely lightweight and robust; it is ideal for hard routes onsight, flash or redpointing where every gram counts
- produced on 44-carrier machine, Route 44, Singing Rock's patented technology
- with our special UIAA water repellent treatment Icon 9.3 Dry is ideal for rock climbing, pumpy routes or extreme ascents in the mountains

- DRY technology is applied on the ropes by revolutionary nanotechnology
- the sheath is more resistant against breakage, but on the other hand it is smoother
- DRY treatment
- Thermotransfer end marking
- Middle marking
- Ultrasonic ending

CE 1019 • EN 892 • UIAA • ①

ICON 9.3



L0380YX



Excellent single rope for high-level climbers.

- extremely lightweight and robust; it is ideal for hard routes onsight, flash or redpointing where every gram counts
- produced on 44-carrier machine, Route 44, Singing Rock's patented technology
- this unique technology gives to the rope great handling, low-weight and high durability
- the sheath is more resistant against breakage, but on the other hand it is smoother

- Thermotransfer end marking
- Middle marking
- Ultrasonic ending

CE 1019 • EN 892 • UIAA • ①

HERO DRY 9.6



L0524GW

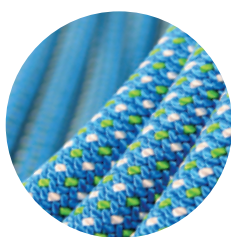

A top-class single rope with low weight and great handling qualities for high-level climbers.

- Single Tech construction provides increased resistance to abrasion and great handling qualities
- rope is soft and easy to manipulate in the belay devices
- although having a small diameter, this rope provides long lifespan
- special UIAA water repellent treatment provides longer lifetime during the usage

- DRY technology is applied on the ropes by revolutionary nanotechnology
- ideal for sport climbing and single pitch ice climbing
- DRY treatment
- Thermotransfer end marking
- Middle marking
- Ultrasonic ending

CE 1019 • EN 892 • UIAA • ①

HERO 9.6

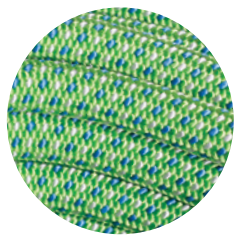

L0520GW

**Excellent single rope for sport climbers.**

- Single Tech construction provides increased resistance to abrasion, low weight and great handling qualities
- rope is soft and easy to manipulate in the belay devices
- even with a small diameter, this rope provides long lifespan
- Thermotransfer end marking
- Middle marking
- Ultrasonic ending

CE 1019 • EN 892 • • ①

KATA DRY 9.7

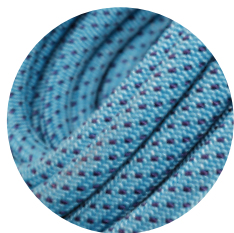

L0580AA

**High-end climbing single rope with high safety factors and extremely high durability. Suitable for both experienced climbers and beginners.**

- the unique patented InterCore technology provides maximum safety even in case of a damaged sheath
- narrow diameter and great handling provide easy manipulation in all belay devices
- thanks to the sandwich-type construction of braided layers and the use of specially

developed staple fibres the rope has super high resistance to abrasion.

- special UIAA water repellent treatment provides longer lifetime during the usage.
- Treatment is applied on the core and sheath by revolutionary nanotechnology.
- Thermotransfer end marking
- Middle marking
- Ultrasonic ending

CE 1019 • EN 892 • • ①

KATA 9.7

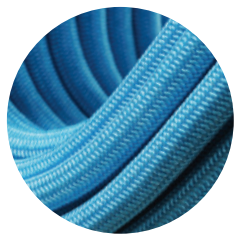

L057AA

**High-end climbing single rope with high safety factors and extremely high durability. Suitable for both experienced climbers and beginners.**

- narrow diameter and great handling provide easy manipulation in all belay devices
- the unique patented InterCore technology provides maximum safety even in case of a damaged sheath
- thanks to the sandwich-type construction of braided layers and the use of specially

developed staple fibres the rope has super high resistance to abrasion.

- Thermotransfer end marking
- Middle marking
- Ultrasonic ending

CE 1019 • EN 892 • • ①

STORM DRY 9.8

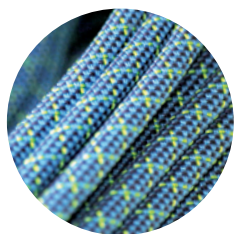

L3044AG00

**Single rope with great balance in weight, durability and use. Perfect choice for all-round climbing.**

- this rope provides great handling, low-weight and high durability
- DRY treatment provides longer lifetime during the usage
- special UIAA water repellent treatment is applied on the ropes by revolutionary nanotechnology which makes the top of the line impregnated ropes

- narrow diameter and higher UIAA fall rating (UIAA falls 9) help you to improve your climbing achievements
- ideal for all-round climbing, training hard routes and RP ascents.
- Thermotransfer end marking
- Middle marking
- Ultrasonic ending

CE 1019 • EN 892 • • ①

STORM 9.8

L3040GA00

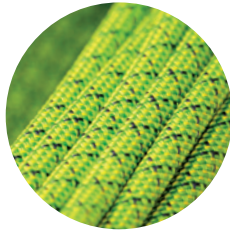

Single rope with great balance in weight, durability and use. Perfect choice for all-round climbing.

- narrow diameter and higher UIAA fall rating (UIAA falls 9) help you to improve your climbing achievements
- this rope provides great handling, low-weight and high durability
- the rope is very compact, durable and pleasant to use
- ideal for all-round climbing, training hard routes and RP ascents.

- Thermotransfer end marking
- Middle marking
- Ultrasonic ending

 €€ 1019 • EN 892 •  • ①

GYM 10.1

L3050RY00



Single rope specially invented for the climbing gyms, adventure parks or rope courses.

- this rope is designed for heavy usage with high safety factors and extremely high durability
- special technology of braided core gives the rope great resistance parameters
- braided core and compact sheath minimize the inter-fiber friction which give the result of the increased resistance to abrasion mainly when top-ropeing

- narrow diameter and great handling provide easy manipulation in all belay devices
- ideal for climbing schools, gyms, adventure parks and rope courses.
- thermotransfer end marking
- ultrasonic ending

 €€ 1019 • EN 892 •  • ①

SCORE DRY 10.1

L0364LA00



General use rope for your climbing activities. Suitable for climbing gyms or sport climbing.

- manufactured using Singing Rock's unique patented Route 44 technology
- this technology gives the rope excellent handling, low weight and long lifetime
- easy to tie and untie knots, pleasant to work with.
- rope is soft and easy to manipulate in all belay devices

- UIAA water repellent treatment achieved by revolutionary nanotechnology, this treatment gives the rope longer lifetime and water resistance
- Thermotransfer end marking
- Middle marking
- Ultrasonic ending

 €€ 1019 • EN 892 •  • ①

 SCORE 10.1 

L0360GG



Great rope for sport climbing with excellent visibility.

- made by Singing Rock patented technology R44, which gives to the rope well-balanced rate of weight and diameter
- this unique technology gives to the rope great handling, low-weight and high durability
- rope is very compact, durable and pleasant to use
- suitable for all belay devices on the market
- Thermotransfer end marking

- Middle marking
- Ultrasonic ending

 €€ 1019 • EN 892 •  • ①

DURAN 10.4 

L0340AX

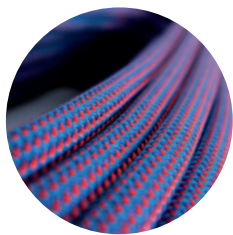
**Ideal rope for indoor climbing and crags with rough rocks.**

- made by Singing Rock patented technology R44, which gives to the rope well – balanced rate of weight and diameter
- rope is very compact, durable and pleasant to use
- rope has thicker sheath with perfect abrasion resistance still keeping good handling characteristics
- suitable for the most types of belay devices on the market

- Thermotransfer end marking
- Middle marking
- Ultrasonic ending

CE 1019 • EN 892 •  • ①

PATRON 11.0

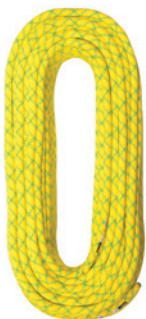
L0540YX
black – L0540BB00**Dynamic single rope with high safety factor and great durability.**

- designed for heavy usage in rope training centres, climbing schools and rescue situations
- rope has thicker sheath with perfect abrasion resistance
- suitable for the most types of the belay devices on the market
- Thermotransfer end marking
- Middle marking

- Ultrasonic ending
- suitable for IRATA cow's tails

CE 1019 • EN 892 •  • ①ACCORD DRY 8.3 

L0514

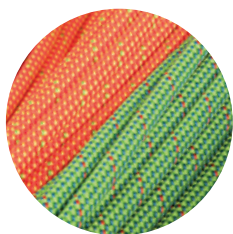
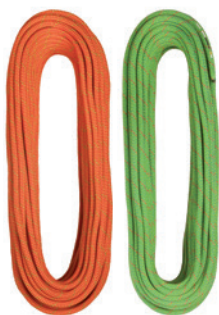
**Half and twin rope with excellent durability and special Teflon® treatment.**

- tested and certified according to the EN 892 standard requirements for half ropes and twin ropes.
- with our special UIAA water repellent treatment is ideal for ice climbing or wet conditions in the mountains
- UIAA water repellent treatment is applied on ropes by revolutionary nano-technology.

- weight, diameter and number of falls are balanced in such a way that can be used as a half and twin rope.
- used in pairs, the climber can choose between the twin rope technique or half rope technique. Whatever technique is required at the time.
- Thermotransfer end marking
- Ultrasonic ending

CE 1019 • EN 892 •  • 1/2 • ③

ACCORD 8.3

L0510

**Half and twin rope with excellent durability and lightness.**

- compact rope which has minimal interfiber friction, thereby increasing durability.
- tested and certified according to the EN 892 standard requirements for half ropes and twin ropes
- weight, diameter and number of falls are balanced in such a way that can be used as a half and twin rope
- used in pairs, the climber can choose between the twin rope technique or half

rope technique. Whatever technique is required at the time.

- Thermotransfer end marking
- Ultrasonic ending

CE 1019 • EN 892 •  • 1/2 • ③

GEMINI DRY 7.9



L3020



Half and twin rope for those who count every gram.

- lightweight rope with top parameters allows wide use: ice climbing, mix routes, glacier tours or mountaineering
- tested and certified according to EN 892 standard requirements as half rope and twin rope
- with our special UIAA water repellent treatment Gemini 7.9 is ideal for ice climbing or extreme ascents in the mountains
- UIAA water repellent treatment is applied on ropes by revolutionary nanotechnology

- used in pairs, the climber can choose between the twin rope technique or half rope technique. Whatever technique is required at the time
- DRY TREATMENT Treatment
- Thermotransfer end marking
- Ultrasonic ending

CE 1019 • EN 892 • UIAA • 1/2 • 10



Grimplay 2023, France • Michal Fanta

THERMOCUTTER

X0004GB



The ideal machine for cutting the ropes and accessory cords. Compact hand-held.

The blade heats quickly. For save and fast cutting the ropes.

ROPEMARKER

E0015XX



When you need to mark your rope, use SINGING ROCK Rope Marker

- with dark ink and easy-to-use design, you'll never be left wondering in those unsure situations
- when the middle marking fades you can mark it again with this specially formulated rope marker
- you can mark the center of ropes or any other part of the harness or sling

For use with: PA, PP, PES, PE.

COW'S TAIL

L0540C450
black - L0540B450



4,5m long piece of 11mm dynamic rope to create lanyards using figure eight knots according to IRATA recommendations.

Length: 4.5 m
Rope diameter: 11 mm
CE 1019 • EN 892 • 



HAMMER CORD

2 mm – L0002
3 mm – L0003



Durable, strong, easy to tie, for example for securing climbing equipment, backpack, tools or laces. Suitable for climbing purposes, guiding or work at height.

Strength: 1.2 kN / 1.9 kN

ACCESSORY CORD

L0041 – L0081



Suitable for a multitude of uses, SINGING ROCK accessory cords are strong and supple.

- easy handling
 - strong
 - multitude of uses
- Diameters: 4, 5, 6, 7 and 8 mm

CE 1019 • EN 564 • 

THROW LINE

L9031YX10



Perfect throwline providing high levels of efficiency to tree climbers.

- excellent sheath-core bond maintains a round cross-section, ensuring good rope glide through the tree
- high visible yellow color for better orientation in the treetop

Diameter: 3mm
Weight: 2,5 g/m
Strength: 0,8 kN
Material: PE (Polyethylen)

ATIKA ROPE PROTECTOR

RK900PP00



Very stable rope protector.

- made of stainless steel
- rubber layer on the lower side eliminates unwanted movement
- ensures safe work at height and load lifting over sharp edges

Weight: 1450 g / 51 oz
Material: stainless steel + rubber

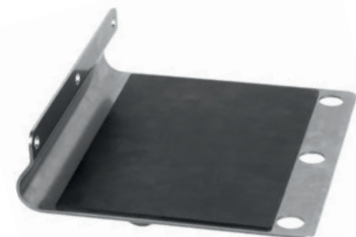

ROPE PROTECTOR

W8100B



Protects rope sheath against abrasion on rough surfaces.

50/70/100/120 cm • 20/28/40/48 in
Material: PVC
Colour: mix colours

DEFENDER

W1027B



Protects rope sheath against abrasion on rough surfaces.

Allows to put 2 ropes in.

80/120 cm • 32/48 in
Material: Cortex

EDGE ROLLER

set – K0050OS03



Compact light edge roller for rope protection made from aluminium alloy.

- suitable for working on the sharp edges
- protects a moving rope against the abrasion.
- fully adjustable to any work situation
- intended for safe work at height or heavy weights hauling
- parts are connected by maillons. Number of parts can be added as needed
- modular perfectly copy the terrain

- anodized side plates
- set includes 3 parts of edge roller and 4 maillons

Weight: 777g • 27.41 oz

EDGE ROLLER – PART

K0050OS01



- it is possible to extend the size of Edge Roller set by adding the separate moduls

Weight: 232g • 8.18 oz

DYNAMIC ROPES

		code	colour	length [m]	diameter [mm]	weight [g/m]	static elong. [%]	dynamic elong. [%]	falls	impact force [kN]	type
DNA DRY 8.9		L3060CX	pink	30 – 80, 100, 200	8,9	51	5 / 4	30 / 27 / 25	6 / 15 / 30	9,9 / 7,2 / 11,5	single / half / twin
ICON DRY		L0384RX	red	30 – 80, 100, 200	9.3	56	7.5	34	5	8.6	single
ICON		L0380YX	yellow	30 – 80, 100, 200	9.3	56	7.5	34	5	8.6	single
HERO DRY		L0524GW	blue	30 – 80, 100, 200	9.6	59	5.1	35	8	7.9	single
HERO		L0520GW	white	30 – 80, 100, 200	9.6	59	5.1	35	8	7.9	single
KATA DRY		L0580AA	azul	30-200	9.7	61	9.0	30	5	7.7	single
KATA		L057AA	azul	30-200	9.7	61	9.0	30	5	7.7	single
STORM DRY		L3044AG	blue	30 – 80, 100, 200	9.8	65	7.9	35	9	9.1	single
STORM		L3040GA	green	30 – 80, 100, 200	9.8	65	7.9	35	9	9.1	single
GYM		L3050RY	red	30 – 80, 100, 200	10.1	68	8.4	35	7	8.7	single
SCORE DRY		L0364LA00	mint	30 – 80, 100, 200	10,1	66	7	32	8	9,1	single
SCORE		L0360GG	green	30 – 60, 80, 100, 200	10.1	66	7	32	8	9.1	single
DURAN		L0340AX	blue	30 – 60, 80, 100, 200	10.4	70	7.1	31	9	9.1	single
PATRON		L0540YX	yellow	30 – 80, 100, 200	11.0	79	5.3	31	16	9.1	single
ACCORD DRY		L0514OG	orange	30 – 70, 100, 200	8.3	43	11 / 6.4	33 / 34	5 / 15	6.3 / 9.7	half / twin
		L0514GO	green	30 – 70, 100, 200	8.3	43	11 / 6.4	33 / 34	5 / 15	6.3 / 9.7	half / twin
ACCORD		L0510AG	blue	30 – 70, 100, 200	8.3	43	11 / 6.4	33 / 34	5 / 15	6.3 / 9.7	half / twin
		L0510GA	green	30 – 70, 100, 200	8.3	43	11 / 6.4	33 / 34	5 / 15	6.3 / 9.7	half / twin
GEMINI DRY		L3020	red	30 – 70, 100, 200	7.9	39	10.5/8	38/33	5/16	5.1/7.9	half / twin
		L3020	yellow	30 – 70, 100, 200	7.9	39	10.5/8	38/33	5/16	5.1/7.9	half / twin

CE • EN 892 • • packaging dynamic ropes: pack – 30. 40. 50. 60. 70. 80. 100 m • spool – 200 m

STATIC ROPES

		code	strength [kN]	knot breaking force [kN]	stitched eye strength [kN]	static elongation [%]	number of falls	weight [g/m]	type
STATIC R44 11.0		L0450	34,9	22,3	28,5	3,2	>20	77	A
STATIC R44 10.5		L0430	31,5	19,8	27,7	3,4	>15	72	A
STATIC 11.0		L0250	34,5	22,0	28,1	3,3	>20	80	A
STATIC 10.5		L0230	30,4	18,6	24,3	3,3	>10	69	A
STATIC R44 NFPA 10.5		R0430	32	–	–	3,5 / 7,2 / 9,9	–	72	general use
STATIC R44 NFPA 11.0		R0450	33,5	–	–	3 / 6,8 / 10,8	–	77	technical use
STATIC R44 NFPA 13.0		R0460	47	30	–	3,4 / 5,4 / 7,6	–	108,7	technical use
STATIC 9.0		L0220	24,4	13,6	–	3,3	>15	54	B
CONTRA 10.5		L026	30	18	–	2	>20	69	A
TILIA 11.5		L0460	30	18	15	3	>20	90	A

CE • EN 1891 • • packaging static ropes: pack – 30. 40. 50. 60. 70. 80. 100 m • spool – 100. 200 m

Static rope characteristic

Type A rope – low stretch kernmantel rope designed for general use by persons in rope access including all kinds of work positioning and restraint; in rescue and in caving Type B rope – low stretch kernmantel rope of a lower performance than type A ropes, requiring greater care in use (standard does not content other specification).

Static strength defined in the standard

22 kN for the ropes of type A • 18 kN for the ropes of type B
Another standard requirement says, the material used for rope production shall have the melting point higher than 195 °C, so polyethylene or polypropylene are not suitable for the production of the ropes.



Rope elongation

The rope elongation shall not be higher than 5%, tested by loading the rope for 3 min with 150kg load (pretension 50 kg)

Dynamic performance



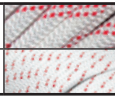

Fall test with two meters long rope terminated with figure-eight knots; fall factor 1. The testing mass 100 kg for type A ropes, 80 kg for type B ropes.

SPELEO ROPES

		strength [kN]	knot breaking force [kN]	static elongation [%]	number of falls	weight [g/m]
SPELEO R44 10.5		33.4	20	3.3	>15	72
SPELEO 10.5		29.4	17.2	4.5	>10	71

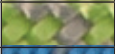
CE • EN 1891 •  packaging speleo ropes: pack – 30. 40. 50. 60. 70. 80. 100 m • spool – 100. 200 m

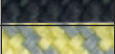
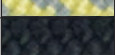
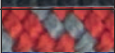
ACCESSORY CORDS

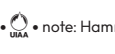
coil		diameter [mm]	weight [g/m]	strength [kN]	length [m]	ft
L0021		2	2.8	1.2	100	328
L0031		3	6.5	1.9	100	328
L0041		4	12.6	3.2	100	328
L0051		5	18.7	5	100	328
L0051BB		5	18.7	5	100	328
L0061		6	23.2	9	100	328
L0061BB		6	23.2	9	100	328
L0071		7	35.1	11.5	100	328
L0081		8	39.8	16	100	328

CE 1019 • EN 564 •  note: Hammer Cords L0002, L0003 do not fulfill EN standards and CE

ROPE TERMINOLOGY:

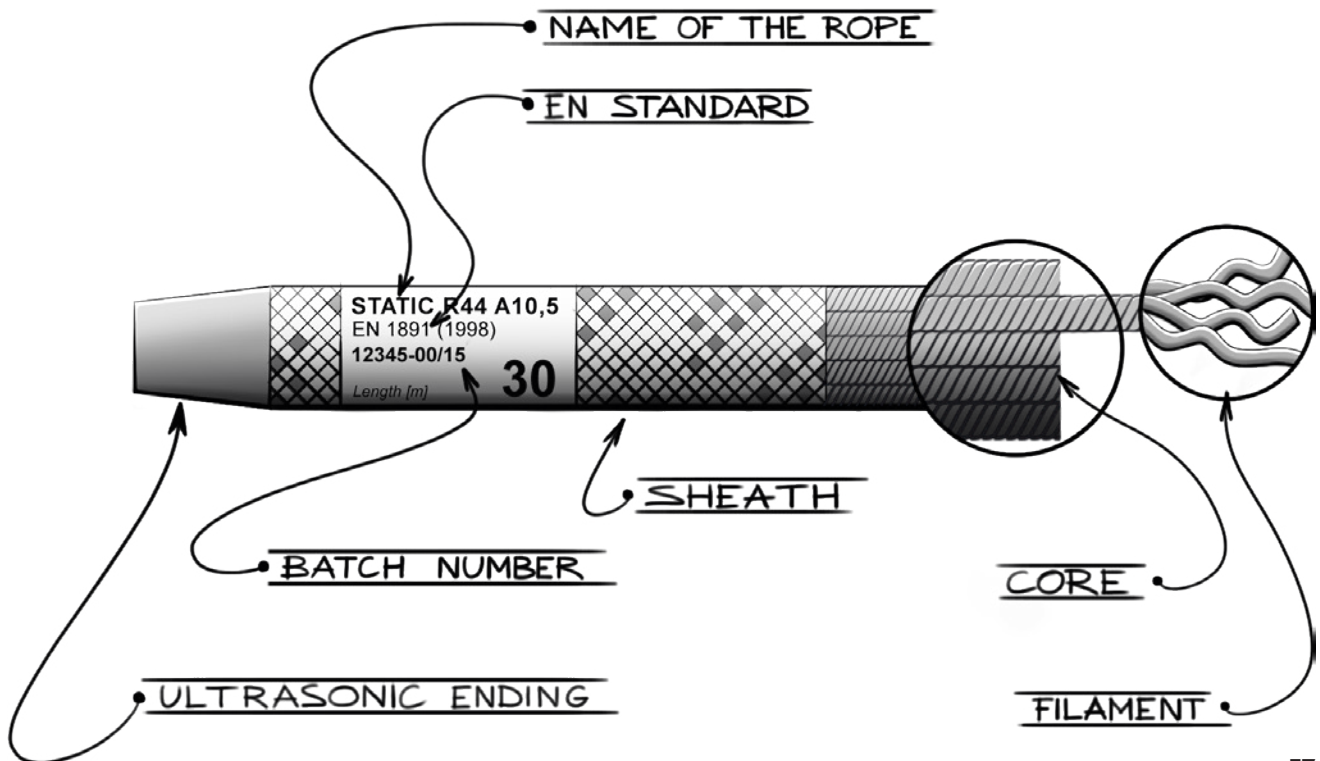





CONNECTORS

STEEL
LIGHT ALLOY
ACCESSORY
CARABINERS



HECTOR / SCREW HECTOR / TRIPLE LOCK

screw – K0114EE00
screw black – K0114BB00
triple lock – K0121EE00
triple lock black – K0121BB00



Large versatile pear-shaped HMS carabiner with screw/triple lock gate designed for multiple uses mainly for belaying or anchoring when working at height. Due to high strength and large gate opening it is mainly used as a central carabiner when anchoring.

- pear-shaped basket facilitates belaying with the MÜNTER hitch or other belay devices
- angled snag free Keylock nose for smooth clipping and unclipping maneuvers
- rough notches on the screw /triple locking sleeve for easy manipulation even with gloves
- each carabiner is individually tested for a strength of 10 kN
- large rope bearing area for better rope glide and reduced wear on the carabiner
- gate opening and basket area are large enough to easily accommodate a big anchor point or more slings
- hot-forged I-beam construction makes the carabiner extremely strong, stiff and light

- excellent ergonomic provides perfect handling with the carabiner
- anodized finishing increases corrosion resistance
- unique production number for better traceability and inspection

Strength: $\blacktriangleleft 30 \blacktriangleright 9 \blacklozenge 8$ kN
Gate opening (d): 26 mm
Weight: screw – 83 g / 2.9 oz
triple – 89 g / 3.1 oz

CE 1019 • EN 12275 • EN 362

HECTOR BC / SCREW HECTOR BC / TRIPLE LOCK

screw BC – K0114EC00
screw BC black – K0114BC00
triple BC – K0121EC00
triple BC black – K0121BC00



Large versatile pear-shaped HMS carabiner with screw/triple lock gate and removable captive bar designed especially as a fixed connector in anchor systems or lanyards.

- captive bar keeps the carabiner in its proper orientation
- bar is easily removable with an Allen key no. 3
- this carabiner keeps your gear well-arranged and minimizes the chance of cross loading
- unique production number for better traceability and inspection

Strength: $\blacktriangleleft 30 \blacktriangleright 9 \blacklozenge 8$ kN
Gate opening (d): 26 mm
Weight: screw – 85 g / 3 oz
Triple – 91 g / 3.2 oz

CE 1019 • EN 12275 • EN 362

BORA / SCREW, BORA / TWL
BORA / TRIPLE LOCK

screw – K0107EE00
screw black – K0107BB00
TWL – K0108EE00

TWL black – K0108BB00
triple lock – K0119EE00
triple lock black – K0119BB00



BORA screw

Versatile pear-shaped HMS locking biner designed for belaying, rappelling and anchor building.

- hot-forged I-beam construction makes the carabiner extremely strong, stiff and light
- large rope bearing area for better rope glide and reduced wear on the carabiner
- pear-shaped basket facilitates belaying with the Münter hitch or other belay devices
- angled snag free Keylock nose for smooth clipping and unclipping maneuvers
- opening and basket area are large enough to easily accommodate the clove hitch
- available with screw, twist and triple lock gate, all of them easy to handle
- for better gear management the screw gates are in different colors
- each carabiner is individually tested for the strength 10 kN
- unique production number for better traceability and inspection



Bora triple

Strength: ◀ 23 ▶ 8 ◻ 8 kN
Gate opening (d): 22 mm
Weight:
Screw 63 g / 2.22 oz
TWL/Triple lock 68 g / 2.4 oz
CE 1019 • EN 12275 • EN 362 • USA



Bora TWL

BORA GP / SCREW

K0107EP00
black – K0107BP00



HMS carabiner designed specifically to eliminate the dangers of cross loading.

- safety wire gate keeps the carabiner in its proper orientation
- hot-forged I-beam construction offers an improved strength/weight ratio
- large rope bearing area for better rope glide and reduced wear on the carabiner
- screw locking sleeve for great handling and effective locking
- very popular for climbing gyms and ropes centres

- each carabiner is individually tested for the strength 10 kN
- unique production number for better traceability and inspection

Strength: ◀ 23 ▶ 8 ◻ 8 kN
Gate opening (d): 22 mm
Weight: 64 g / 2.26 oz
CE 1019 • EN 12275 • EN 362 • USA

COLT / SCREW

K0112EE00
black – K0112BB00



Our smallest, super light locking carabiner. Ideal for belaying and anchor building on trad and alpine climbs.

- hot-forged I-beam construction makes the biner very light and still extremely strong with 11 kN gate open rating
- angled snag free Keylock nose for smooth clipping and unclipping maneuvers
- ergonomic shape and gate position designed to provide large opening and large basket area
- screw locking sleeve for great handling and effective locking
- for better gear management the screw gates are in different colors
- each carabiner is individually tested for the strength 10 kN
- unique production number for better traceability and inspection

Strength: \blacktriangleleft 26 \blacktriangleright 8 \square 11 kN

Gate opening (d): 18 mm

Weight: 48 g / 1.69 oz

CE 1019 • EN 12275 • EN 362 • 

COLT SCREW 3PACK

K0112XX30



Three super light and small locking carabiners for belaying and anchoring for reduced price.

- screw locking sleeve for great handling and effective locking
- for better gear management the screw gates are in different colors
- each carabiner is individually tested for the strength 10 kN

Strength: \blacktriangleleft 26 \blacktriangleright 8 \square 11 kN

Gate opening (d): 18 mm

Weight: 48 g / 1.69 oz

CE 1019 • EN 12275 • EN 362 • 

OXY / SCREW, OXY / TWL,
OXY / TRIPLE LOCK

Screw – K0122EE05
Screw black – K0122BB05
TWL – K0122EE06

TWL black – K0122BB06
Triple lock – K0122EE07
Triple lock black – K0122BB07



Hot-forged light alloy oval carabiners designed to be used especially with pulleys, ascenders and descenders.

- hot-forged I-beam construction makes the carabiner extremely strong, stiff and light
- rough notches on the locking sleeve for easy manipulation
- angled snag free Keylock nose for smooth clipping and unclipping
- almost oval shape makes the carabiner easy to turn around in device's attachment points, anchors or slings
- thanks to the oval shape, pulleys attached are loaded symmetrically
- large rope bearing area for better rope glide and reduced wear of the carabiner

- each carabiner is individually tested for a strength of 10 kN
- anodized finishing increases the corrosion resistance
- unique production number

Strength: ◀ 26 ⬥ 8 ◻ 7 kN
Gate opening (d): 21 mm
Weight:
Screw: 74 g • 2.61 oz
TWL/Triple lock: 81 g • 2.86 oz
CE1019 • EN 12275 • EN 362

OXY BC / SCREW, OXY BC / TWL
OXY BC / TRIPLE LOCK

Screw – K0123EC05
Screw black – K0123BC05
TWL – K0123EC06

TWL black – K0123BC06
Triple lock – K0123EC07
Triple lock black – K0123BC07



Hot-forged light alloy oval carabiner with a removable captive bar.

- captive bar keeps the carabiner in its proper orientation
- the bar is easily removable with an Allen key no. 2
- this carabiner keeps your equipment well-arranged and minimizes the chance of cross loading
- missing captive bar does not affect the strength of the carabiner and it is allowed to use the carabiner without a bar
- serial unique number for better traceability and inspection

Strength: ◀ 26 ⬥ 8 ◻ 7 kN
Gate opening (d): 21 mm
Weight:
Screw: 76 g • 2.68 oz
TWL/Triple lock: 83 g • 2.93 oz
CE1019 • EN 12275 • EN 362



OZONE / SCREW, OZONE /
TWL, OZONE / TRIPLE LOCK

screw – K0016AA00
screw black – K0016BB00

twist lock – K0017AA00
twist lock black – K0017BB00
triple lock – K0018AA00
triple lock black – K0018BB00



OZONE SCREW



OZONE TWISTLOCK

Oval carabiner with screw/twist/triple lock gate designed to be used with pulleys, ascenders and descenders.

- almost oval shape makes the carabiner easy to turn around in device's attachment points, anchors or slings
- angled snag free Keylock nose for smooth clipping and unclipping
- each carabiner is individually tested for a strength of 10 kN
- unique production number



OZONE TRIPLELOCK

Strength: ∇ 26 kN ∇ 10 kN ∇ 7 kN

Gate opening (d): 21 mm

Weight: 80 g – screw, 85 g – TWL, triplelock

CE 1019 • EN 362 • EN 12275

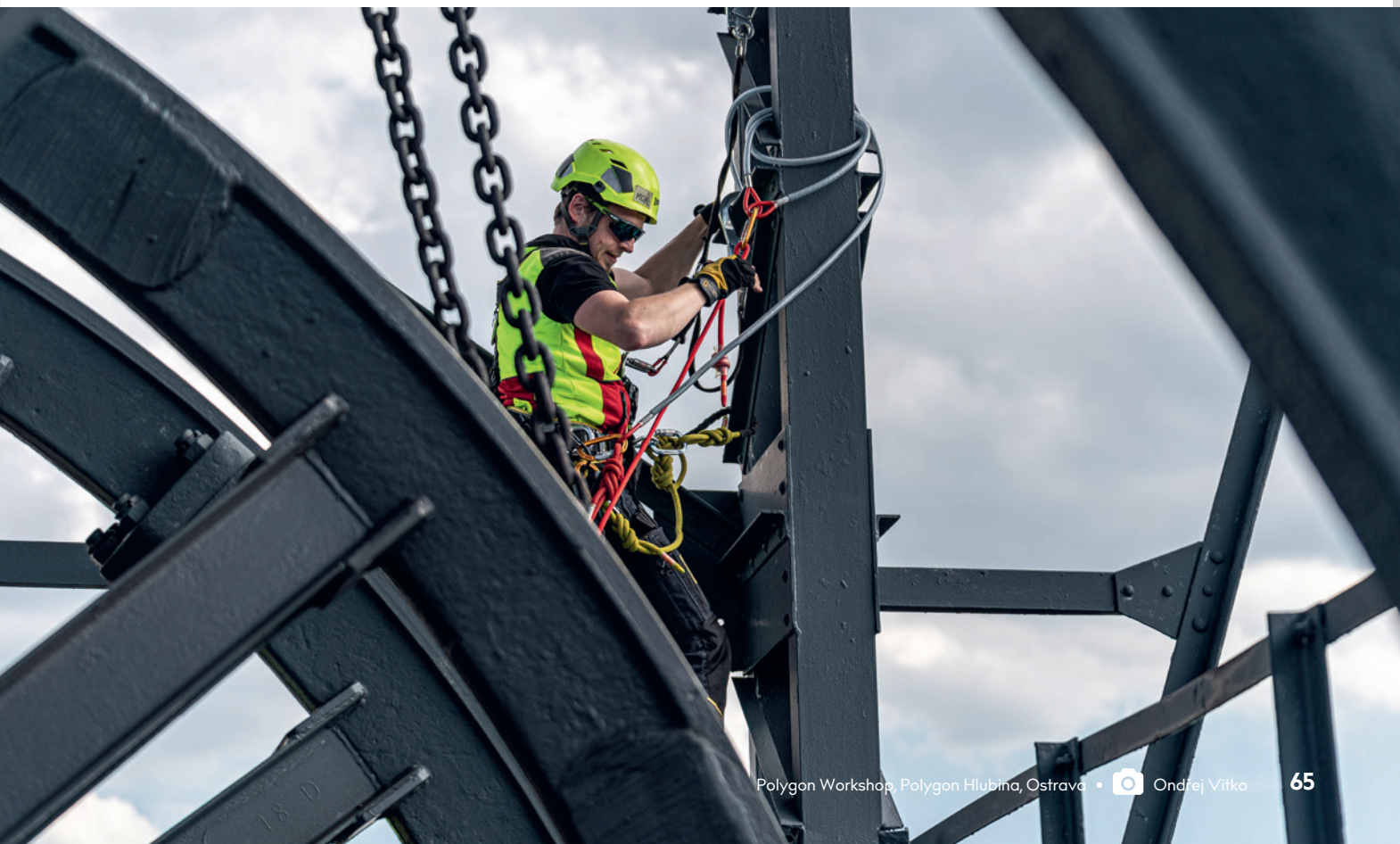

MAILLON MINI OVAL

K82006Z



D 6 mm • 4 kN
gate opening 7,5 mm
zinc-plated • 33 g

MAILLON SMALL OVAL

K82008Z



D 8 mm • 35 kN
gate opening 11 mm
zinc-plated • 77 g
CE 0082 • EN 12275
• EN 362 • 

MAILLON SMALL DELTA

K82207Z



D 7 mm • 4 kN
gate opening 8,5 mm
zinc-plated • 58 g

MAILLON BIG D

K82310Z



D 10 mm • 45 kN
gate opening 10 mm
zinc-plated • 153 g
CE 0082 • EN 12275
• EN 362 • 

MAILLON BIG DELTA

K82210Z



D 10 mm • 45 kN
gate opening 12 mm
zinc-plated • 153 g
CE 0082 • EN 12275
• EN 362 • 

BIG SQUARE

K82410Z



D 10 mm • 45 kN
gate opening 12 mm
zinc-plated • 166 g • 5.86 oz
CE 0082 • EN 12275
• EN 362 • 

BIG TWIST

K82508Z



D 8 mm • 32 kN
gate opening 17,5 mm
zinc-plated • 106 g • 3.74 oz
CE 0082 • EN 12275
• EN 362 • 

SMALL CONNECTOR

K3702PP
steel - K3690ZO



Small connector with double trigger
automatic locking
gate opening 21 mm • 25 kN
polished, Al • 150 g • 5.29 oz
unique production number
CE 0333 • EN 362

D STEEL / SCREW

K4080ZO



D steel connector / screw
with screw gate, key lock, zinc plated
◀▶50 kN ▲13 kN ◻20 kN
gate opening (d) 25 mm • 255 g • 9 oz
unique production number
CE 1019 • EN 362

D STEEL / TRIPLE LOCK

K4081ZO



D steel connector /triplelock
with triplelock gate, key lock, zinc plated
◀▶50 kN ▲13 kN ◻20 kN
gate opening (d) 25 mm • 267 g • 9 oz
unique production number
CE 1019 • EN 362

OVAL STEEL / TRIPLE LOCK

K4241ZO07



Oval steel connector /triplelock
with key lock and triplelock gate
◀▶30 kN ▲9 kN ◻8 kN
gate opening (d) 18 mm • 195 g • 6.9 oz
unique production number
CE 1019, EN 362

PALM CONNECTOR

yellow - K0124SY09
grey - K0124ST09



Light alloy double action carabiner
designed to be used especially on Via Ferrata routes, also certified as an industrial termination connector.

- hot forged gate
- double action opening system
- wear indicator shows when to retire the carabiner from use
- anodized finishing increases corrosion resistance
- carabiner is available in two color versions (with yellow or grey gate)
- each carabiner is individually tested for a strength of 10 kN
- unique serial number

OVAL STEEL / SCREW

K4241ZO05



Oval steel connector / screw
with screw gate, key lock, zinc-plated
◀▶30 kN ▲9 kN ◻8 kN
gate opening (d) 18 mm
176 g • 6,21 oz
unique production number
CE 1019 • EN 362

Weight: 117 g / 4.1 oz
Material: aluminum alloy, plastic, stainless steel
Strength: ▶ 28 kN ▲ 14 kN ◻ 7 kN
Gate opening (d): 28 mm
CE 1019 • EN 362/T • EN 12275/K

CONNECTOR GIGA

K3550PP00



with double trigger
automatic locking
gate opening 110 mm • 25 kN
polished, Al • 965 g • 34.04 oz
unique production number
CE 2777 • EN 362

BIG CONNECTOR

K3536PP00



with double trigger
automatic locking
gate opening 60 mm • 28 kN
polished, Al • 450 g • 15.87 oz
unique production number
CE 2777 • EN 362

PORTER XL

K9001BB00

NEW



Having the necessary equipment on hand is a prerequisite for efficient work. When working at heights, our patented large-volume material and tool carrier for work harnesses takes care of that.

- patented PRESS CLICK attachment system allows quick mounting/dismounting on the harness
- EASY WIRE function, leaving the carrier lock in the open position, allows you to simply remove and attach equipment with one hand
- nose on the top serves to organize your equipment and put tools away
- 40 mm gate opening allows for hanging e.g. a chainsaw directly by the handle
- maximum load capacity of 20 kg with a

safety factor of 5 allows heavy loads to be carried

- minimum breaking strength is 100 kg

Weight: 80 g • 2.82 oz

Material: plastic, steel

Gate opening: 40 mm

Max. load: 20 kg

Color: grey

WARNING: NOT FOR CLIMBING!
PORTER XL is not a strength carabiner or anchor point! Do not use it for fall arrest or belay. It is not PPE!

PORTER

K9000BB03



Plastic holder for racking ice screws, pitons and industrial tools.

- for racking ice screws, pitons and industrial tools on the harness
- easy clipping and un-clipping
- the nose on the upper part allows to set away some stuff in order to access stuff on the bottom.
- rubber part fixes the Porter on place and prevent it from rotation

WARNING: NOT FOR CLIMBING!
PORTER is not a strength carabiner or anchor point! Do not use it for fall arrest or belay. It is not PPE!

Gate opening: 23 mm

Max. load: 5 kg

Weight: 32 g • 1.13 oz



MINI PEAR

K5052EE00



accessory carabiners

mix colour • 16 g • 0.56 oz • gate opening (d) 11 mm

Not for climbing.

MINI D

K5182EE00



accessory carabiners

mix colour • 25 g • 0.88 oz • gate opening (d) 14 mm

Not for climbing.

MINI D SCREW

K0027YX00 bronze
K0027BY00 black

Practical accessory carabiner which you will appreciate when climbing or working at heights.

- with the screw lock, you won't lose valuable equipment that you hang on the carabiner.
- suitable as an accessory for keys, for hanging climbing shoes, for attaching a nut tool or water bottle to the harness
- also works well for attaching a hammer, saw or other tools and accessories for working at heights

This carabiner is not a personal protective equipment and is not used for securing persons!

Color: black, bronze
Weight: 28 g • 1 oz
Material: aluminium alloy (anodized)
Strength major axis: 3 kN
Gate opening (d): 12 mm



MINI D SCREW 40 PACK

K0027BY40



Accessory carabiner which you will appreciate when climbing or working at heights. Discounted price pack of 40 pcs in a practical plastic box.

- with the screw lock, you won't lose valuable equipment that you hang on the carabiner
- suitable as an accessory for keys, for hanging climbing shoes, for attaching a nut tool or water bottle to the harness
- also works well for attaching a hammer, saw or other tools and accessories for working at heights

This carabiner is not a personal protective equipment and is not used for securing persons!

Color: black, bronze
Weight: 28 g • 1 oz
Material: aluminium alloy (anodized)
Strength major axis: 3 kN
Gate opening (d): 12 mm

SCREW LOCK

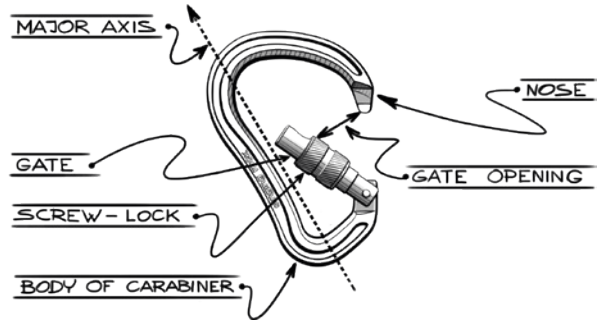

TWL- TWIST LOCK



TRIPLE LOCK

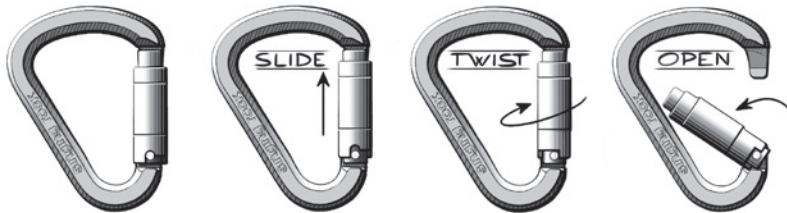

GATE OPENING (d)



TECHNOLOGY



KEYLOCK

for easy manipulation

Key lock is an extremely simple and ingenious locking system that solves the problems associated with the traditional design of carabiners. It eliminates any risk of ropes or slings becoming entangled in the gate or in the carabiner nose when it is being connected or released. Neither the gate, which is completely cylindrical, nor the nose has any sharp edges. Ropes and slings do not, therefore, come into the contact with any cutting edges.



HOT FORGING

the latest technology in manufacturing of light alloy hardware

Aluminum alloy is heated state when being forged into the final shape. This allows the metal to be formed more easily so it can be moved to areas where it is needed and removed from the areas where it is not needed.

In comparison with cold forged binners, the hot forged binners are lighter, more durable and stronger.























UNIQUE PRODUCTION NUMBER

identification of metal parts

For better traceability and inspection recording the Singing Rock metal parts are marked with the unique production number. Singing Rock metal parts marked with the unique production number are in this catalogue indicated with text "unique production number".



type	preview	code	colour / surface	material	EN12275 sport	EN362 work	↔ kN	⇕ kN	⊖ kN	gate open. [mm]	weight [g]	oz
D STEEL / SCREW		K4080ZO	zinc-plated	steel	✗	✓	50	13	20	25	255	8.9
D STEEL / TRIPLE LOCK		K4081ZO	zinc-plated	steel	✗	✓	50	13	20	25	267	9.4
OVAL STEEL / SCREW		K4241ZO05	zinc-plated	steel	✗	✓	30	9	8	18	176	6.2
OVAL STEEL / TRIPLE LOCK		K4241ZO07	zinc-plated	steel	✗	✓	30	9	8	18	195	6.9
COLT / SCREW		K0112EE00	mix	AL alloy	✓	✓	26	8	11	18	48	1.7
		K0112BB00	black	AL alloy	✓	✓	26	8	11	18	48	1.7
BORA / SCREW		K0107EE00	mix	AL alloy	✓	✓	23	8	8	22	63	2.2
		K0107BB00	black	AL alloy	✓	✓	23	8	8	22	63	2.2
BORA / TWL		K0108EE00	grey	AL alloy	✓	✓	23	8	8	22	68	2.4
		K0108BB00	black	AL alloy	✓	✓	23	8	8	22	68	2.4
BORA / TRIPLE LOCK		K0119EE00	orange	AL alloy	✓	✓	23	8	8	22	68	2.4
		K0119BB00	black	AL alloy	✓	✓	23	8	8	22	68	2.4
BORA GP / SCREW		K0107EP00	grey	AL alloy	✓	✓	23	8	8	22	64	2.3
		K0107BP00	black	AL alloy	✓	✓	23	8	8	22	64	2.3
HECTOR / SCREW		K0114EE00	blue	AL alloy	✓	✓	30	9	8	26	83	2.9
		K0114BB00	black	AL alloy	✓	✓	30	9	8	26	83	2.9
HECTOR / TRIPLE LOCK		K0121EE00	blue	AL alloy	✓	✓	30	9	8	26	89	3.1
		K0121BB00	black	AL alloy	✓	✓	30	9	8	26	89	3.1
HECTOR BC / SCREW		K0114EC00	blue	AL alloy	✓	✓	30	9	8	26	85	3
		K0114BC00	black	AL alloy	✓	✓	30	9	8	26	85	3
HECTOR BC / TRIPLE		K0121EC00	blue	AL alloy	✓	✓	30	9	8	26	91	3.2
		K0121BC00	black	AL alloy	✓	✓	30	9	8	26	91	3.2
OXY SCREW		K0122EE05	golden	AL alloy	✓	✓	26	8	7	21	74	2.6
		K0122BB05	black	AL alloy	✓	✓	26	8	7	21	74	2.6
OXY TWL		K0122EE06	golden	AL alloy	✓	✓	26	8	7	21	81	2.9
		K0122BB06	black	AL alloy	✓	✓	26	8	7	21	81	2.9

type	preview	code	colour / surface	material	EN12275 sport	EN362 work	↔ kN	⊕ kN	⊖ kN	gate open. [mm]	weight [g]	oz
OXY TRIPLE LOCK		K0122EE07	golden	AL alloy	✓	✓	26	8	7	21	81	2.9
		K0122BB07	black	AL alloy	✓	✓	26	8	7	21	81	2.9
OXY BC SCREW		K0123EC05	golden	AL alloy	✓	✓	26	8	7	21	76	2.7
		K0123BC05	black	AL alloy	✓	✓	26	8	7	21	76	2.7
OXY BC TWL		K0123EC06	golden	AL alloy	✓	✓	26	8	7	21	83	2.9
		K0123BC06	black	AL alloy	✓	✓	26	8	7	21	83	2.9
OXY BC TRIPLE LOCK		K0123EE07	golden	AL alloy	✓	✓	26	8	7	21	83	2.9
		K0123BB07	black	AL alloy	✓	✓	26	8	7	21	83	2.9
OZONE / SCREW		K0016AA00	blue	AL alloy	✓	✓	26	10	7	21	80	2.8
		K0016BB00	black	AL alloy	✓	✓	26	10	7	21	80	2.8
OZONE / TWL		K0017AA00	blue	AL alloy	✓	✓	26	9	7	21	85	3
		K0017BB00	black	AL alloy	✓	✓	26	9	7	21	85	3
OZONE / TRIPLE LOCK		K0018AA00	blue	AL alloy	✓	✓	26	9	7	21	85	3
		K0018BB00	black	AL alloy	✓	✓	26	9	7	21	85	3
SMALL CONNECTOR		K3702PP	silver	AL alloy	✗	✓	25			21	150	5.3
		K3690ZO	zinc-plated	steel	✗	✓	25			244	244	8.6
BIG CONNECTOR		K3536201	silver	AL alloy	✗	✓	28			60	450	15.9
GIGA CONNECTOR		K3550PP	silver	AL alloy	✗	✓	25			110	965	34
PALM CONNECTOR		K0124SY09	yellow	AL alloy	✓	✓	28	14	7	28	117	4.1
		K0124ST09	grey	AL alloy	✓	✓	28	14	7	28	117	4.1



singing
rock

SAFETY
FIRST

Wind turbine Liberec, Czechia •  Ondřej Vítko



HELMETS

WORK
SPORT



BLAST

W9607

NEW

Super comfortable and lightweight helmet for work at heights. Thanks to its well thought-out design and numerous features, it fits like a glove and you'll want to wear it all day long.

- lightweight construction with EPS liner, which is found in comfy sports helmets, will keep you comfortable even when working long hours
- optimally deep profile ensures better stability on the head
- you can tune the depth as needed with the height-adjustable forehead band, so the helmet won't fall backwards or into your eyes
- helmet is ventilated by vent holes which are covered by a steel grille
- side buckles under the ears with adjustable positioning ensure ideal routing of the straps around the ears and under the chin
- newly designed chin buckle is low-profile and works like a charm
- headband circumference can be easily adjusted between 53-61 cm using the rear rotary wheel
- for easy transport and storage, the back part of the headband with the adjustment wheel can be folded into the shell
- inner padding is removable and washable
- integrated universal 30 mm euro slots are compatible with most hearing protectors on the market as well as the Singing Rock LAMPFIX lamp holder
- smaller integrated slots are designed for connecting the Singing Rock COVER shield
- clips for attaching a head lamp are recessed thus snag-free when dressing or working
- thanks to reflective stickers, no one will miss you even in low visibility

- helmet can be used safely in temperatures ranging from -10 to +50 °C
- unique product number makes it easy to keep track of periodic inspections
- available in six colors, find yours

W9607MX00 BLAST BERRY BLUE
 W9607YX00 BLAST NEON YELLOW
 W9607BX00 BLAST ONYX BLACK
 W9607RX00 BLAST ORIENT RED
 W9607WX00 BLAST POLAR WHITE
 W9607ZX00 BLAST SAFFRON GOLD

CE, EN 397

Color: berry blue, neon yellow, onyx black, orient red, polar white, saffron gold

Weight: 410 g • 14.5 oz

Size: UNI (53-61 cm)

Material: main materials ABS/PC, EPS, POM, PP, PA



FLASH



Professional protective helmets designed with emphasis to comfortability and durability. Helmets are available in two models depending on the user's choice according the working situation.

- helmet construction with shock resistant ABS/PC shell and without EPS lining provides great ventilation and comfort for user
- fully adjustable headband with two side and two rear adjusting sleeves to regulate the length of the chin straps
- fast, easy and durable size adjustment mechanism on the back of the helmet with UNI size 53–63 cm
- suspension straps easily adjustable to 3 depth levels

- four head lamp holders for any head lamp available on the market
- inner padding fully removable and hand or machine washable at 30 °C (86 °F)
- helmets can be safely used in the temperatures ranging from –30 to +50 °C (–22 to 122 °F)
- universal 30 mm accessory slot is compatible with most of the visors and hearing protectors on the market
- certified with Hellberg safety ear muffs
- reflective stickers included
- unique number marking



FLASH INDUSTRY

red – W9601RX00
white – W9601WX00

yellow – W9601YX00
black – W9601BB00
high visible – W9601QX00



Professional safety helmet for industrial work and construction sites. Its main purpose is to protect the user against falling objects and voltage.

- safety chin strap in compliance with EN 397 is released at a load ranging between 15 and 25 daN (approx. 15–25 kg), which eliminates the risk of strangling
- suitable for working situations where, in case of fall, the risk of strangling is higher than risk of dropping the helmet
- fulfils EN 397 optional requirements: low temperature (–30°C), lateral deformation, electrical insulation (440V a.c.)
- five color variants
- fulfils side impact force requirements according to EN 12492

Weight: 455 g • 16.05 oz
Material: ABS/PC
Size: UNI (53–63 cm)
Color: yellow, white, red, black, high-visibility yellow
€€ 1015 • EN 397 (LD, 440V a.c., –30 °C)

FLASH ACCESS

red – W9603RX00
high visible yellow – W9603QX00



Protective helmet for work at heights, and rescue purposes. It is primarily intended for protection against falling objects and to protect against voltage.

- helmet has a solid chin strap that will withstand a load of at least 50 kg, which prevents the possibility of dropping the helmet in case of fall
- suitable for work at heights activities where, in case of fall, the risk of dropping the helmet is higher than risk of strangling
- partly meets the requirements the requirements of EN 397 and EN 12492
- fulfils EN 397 optional requirements: low temperature (–30°C), lateral deformation, electrical insulation (440V a.c.)

- fulfils side impact force requirements according to EN 12492

Weight: 455 g • 16.05 oz
Material: ABS/PC
Size: UNI (53–63 cm)
Color: red, high-visibility yellow
€€ (LD, 440V a.c., –30 °C)
€€ 1015

FLASH AERO

red – W9602RX00
high-visibility yellow – W9602QX00



Protective well ventilated helmet for work at heights, and rescue purposes. Suitable for physically hard working persons. Its main purpose is to protect the user against falling objects.

- helmet has a solid chin strap that will withstand a load of at least 50 kg, which prevents the possibility of dropping the helmet in case of fall
- suitable for work at heights activities where, in case of fall, the risk of dropping the helmet is higher than risk of strangling
- partly meets the requirements the requirements of EN 397 and EN 12492

- fulfils ventilation requirements according to EN 12492 which ensures better ventilation for physically hard working persons and persons working in excessively warm environments
- fulfils side impact force requirements according to EN 12492

Weight: 455 g • 16.05 oz
Material: ABS/PC
Size: UNI (53–63 cm)
Colors: red, high-visibility yellow
€€

PENTA

C0091



The second generation of the popular, lightweight, comfortable and ventilated climbing helmet. Due to its comfort and lightweight construction, it is ideal for sport climbing, trad climbing, mountaineering and via ferratas.

- the first climbing helmet on the market in three sizes (S 48-54 cm, M/L 52-58 cm, XL 56-62 cm) for the widest range of users
- 30 % larger vent area than the first generation ensures excellent ventilation even on the hottest summer days
- weight under 200 g (size M/L) ensures comfort for all-day climbing
- compact upper protects the user from falling objects, yet maintains a low profile
- hard PC shell protects against sharp objects, while PS foam absorbs the impact force
- thanks to its low profile, the helmet does not get in the way when climbing and fits neatly on the head
- comfortable and easy size adjustment system with straps that don't squeeze even after a full day of climbing
- soft and wide chin strap ensures maximum comfort and its length allows a scarf or hat to be worn under the helmet
- clips for attaching the head lamp are recessed to avoid catching them when removing the slings or hood from the jacket
- inner padding is in one piece to prevent the loss of smaller parts, holds better, is completely removable and washable
- available in 4 colors with a modern look

C0091YX02	PENTA S yellow gold
C0091YX03	PENTA M/L yellow gold
C0091YX05	PENTA XL yellow gold
C0091GX02	PENTA S mint green
C0091GX03	PENTA M/L mint green
C0091GX05	PENTA XL mint green
C0091SX02	PENTA S olivine gray
C0091SX03	PENTA M/L olivine gray
C0091SX05	PENTA XL olivine gray
C0091FX02	PENTA S spruce blue
C0091FX03	PENTA M/L spruce blue
C0091FX05	PENTA XL spruce blue

CE, EN 12492

Color: yellow gold, mint green, olivine gray, spruce blue

Weight: S 185 g • 6.5 oz,
M/L 195 g • 6.9 oz,
XL 205 g • 7.2 oz

Size: S (48-54 cm • 19-21 in),
M/L (52-58 cm • 20.5-23 in),
XL (56-62 cm • 22-24.5 in)

Material: PC, EPS, PA, POM, PE foam, rubber



PENTA JUNIOR

C0091JY02



Lightweight, comfortable and fully ventilated helmet for the smallest climbers. For its comfort and lightweight construction, it is ideal for sport climbing, mountaineering and via ferratas.

designed for child users with a small head circumference (48-54 cm)
with a weight of 185 g, your child will not know he/she is wearing a helmet
large vent area guarantees excellent ventilation even on the hottest summer days
compact top protects children from falling objects, yet maintains a low profile
hard PC shell protects against sharp objects, while PS foam absorbs the impact force
thanks to its low profile, the helmet does not get in the way when climbing and fits neatly on the head
soft, wide chin strap ensures maximum comfort and its length allows a scarf or hat

to be worn under the helmet
comfortable and easy size adjustment system with straps that do not squeeze even after a full day of wear
inner padding is in one piece to prevent the loss of smaller parts, holds better, is completely removable and washable
recessed clips for attaching any head lamp on the market
comes with stickers for your child to create their own unique design

Color: arnica yellow / dark teal

Weight: 185 g - 6.5 oz

Size: UNI (48-54 cm)

Material: PC, EPS, PA, POM, PE foam, rubber
CE • EN 12492



HEX



Durable, fully ventilated helmet for climbing, mountaineering and other rope activities. Due to its durability, ventilation and versatility, it is suitable for both sport and trad climbing, via ferrata or rope parks.

- durable EPP + ABS shell protects against falling objects and guarantees a high degree of protection against impact force, including repeated impact force
- the „OPEN CELL“ construction with 35 ventilation holes with a total area of 108 cm² guarantees maximum ventilation
- easy and quick size adjustment mechanism in the back of the helmet
- chin strap made of a soft and wide webbing provides maximum comfort
- inner padding is made as one piece, which prevents the loss of smaller parts and holds better
- inner padding is removable and washable
- integrated „EASY CLIP“ front clips for reliable attachment of a headlamp, their shape prevents jamming of a hood / slings
- the „UNI FIX“ elastic system on the backside simply attaches any headlamp or ski goggles
- available in two sizes (M 52/58cm a L 55/61cm)
- modern design and 5 colors

Size M (52-58 cm):

ice white	C0900WX03
arnica yellow	C0900YX03
garish blue	C0900MX03
mountain lake azure	C0900AX03
fox red	C0900RX03

Size L (55-61 cm):

ice white	C0900WX04
arnica yellow	C0900YX04
garish blue	C0900MX04
mountain lake azure	C0900AX04
fox red	C0900RX04

Weight: M 300 g • 10.6 oz,

L 330 g • 11.6 oz

CE • EN 12492





HELMETS

	name	code	color	head circumference (cm)	weight (g)	EN 397	EN 12492	CE						
	BLAST	W9607	yellow, black, white, red, gold	53-61	410	✓	✗	CE 1015	15-25 kg	440V a.c.	✗	-10 °C	✗	✗
	FLASH INDUSTRY	W9601	yellow, white, red, black, high-visibility yellow	53-63	455	✓	✗	CE 1015	15-25 kg	440V a.c.	✗	-30 °C	✓	✓
	FLASH ACCESS	W9603	red, high visible yellow	53-63	455	✗	✗	CE 1015	min. 50 kg	440V a.c.	✗	-30 °C	✓	✓
	FLASH AERO	W9602	red, high visible yellow	53-63	455	✗	✗	CE	min. 50 kg	✗	✓	-10 °C	✗	✓
	PENTA	C0091	yellow gold, mint green, olive gray, spruce blue	48-54 / 52-58 / 56-62	185 / 195 / 205	✗	✓	CE	min. 50 kg	✗	✓	-10 °C	✗	✓
	PENTA JUNIOR	C0091JY02	arnica yellow, dark teal	48-54	185g	✗	✓	CE	min. 50 kg	✗	✓	-10 °C	✗	✓
	HEX	C0900	ice white, arnica yellow, garish blue, mountain lake azure, fox red	52-58 / 55-61	300 / 330	✗	✓	CE	min. 50 kg	✗	✓	-10 °C	✗	✓

SAFE PC ELECTRIC ARC VISOR X0049XX00



Visor providing protection against electric arc up to 400 volts.

- approved to medium impact and suitable for electrical work
- visor is possible to attach with or without the earmuffs
- for attaching to the FLASH helmet SAFE 2 FLEX CARRIER and SECURE earmuffs or CLASSIC ADAPTOR are needed

Material: PC
Length: 200mm • Weight: 116g
Thickness: 1,5mm
CE • EN 166/1B389 • EN 170/2-1,2

SAFE NYLON MESH VISOR X0051XX00



Light weight and non-conductive visor which stays close to your face for great coverage.

- gives a comfortable airflow
- approved to low impact
- visor is possible to attach with or without the earmuffs
- for attaching to the FLASH helmet SAFE 2 FLEX CARRIER and SECURE earmuffs or CLASSIC ADAPTOR are needed

Light transmission 58–61%
Length: 185mm
Weight: 36g
CE EN 1731/F • ANSI Z87

SAFE STEEL MESH VISOR X0050XX00



The unique hexagon shaped etching provides superior light transmission for added safety in low-light conditions.

- stays close to your face for great coverage
- gives comfortable airflow
- approved to low impact and suitable for applications such as forestry work and grass/bush trimming
- visor is possible to attach with or without the earmuffs
- for attaching to the FLASH helmet SAFE 2 FLEX CARRIER and SECURE earmuffs or CLASSIC ADAPTOR are needed

Weight: 52g • Material: steel
Light transmission: 82–85,5%
Length: 185mm
CE • EN 1731/F • ANSI Z87

SAFE 2 FLEX CARRIER X0052XX00



Intended for attachment of the visors to helmet using earmuffs or adaptors.

- Compatible with Flash helmets.

CE • EN 166/1731 • ANSI Z87+

CLASSIC ADAPTOR (PAIR) X0053XX00



Allows attachment of the flex carrier for face shield without earmuffs.

- compatible with Flash helmets
- sold in pair

COVER

W9605XX00



Sight is the most important sense. The COVER shield for Singing Rock work helmets protects eyes from fast-moving particles. With this visor, no mess will hit your eye and you'll finish your job without a hitch.

- compatible exclusively with Singing Rock FLASH and Singing Rock BLAST helmets (cannot be used alone or with other helmets)
- designed for professional use, meets PPE Category II requirements
- provides increased protection against fast moving particles
- anti-scratch surface treatment ensures excellent optical performance

- durable positioning mechanism perfectly holds the shield in the open or closed position
- fabric pouch for transport and storage included

Weight: 110 g • 3.9 oz
Material: polycarbonate
CE • EN 166 1 F



COVER SMOKE

W9605TT00

NEW



Sight is the most important sense. The COVER shield for Singing Rock work helmets protects eyes from fast-moving particles and, in the SMOKE variant, from the harsh sun. With this visor, no mess will hit your eye and you'll finish your job without a hitch.

- compatible exclusively with Singing Rock FLASH and Singing Rock BLAST helmets (cannot be used alone or with other helmets)
- designed for professional use, meets PPE Category II requirements
- provides increased protection against fast moving particles
- level 2.5 filter protects eyes from sunlight
- anti-scratch surface treatment ensures excellent optical performance

- durable positioning mechanism perfectly holds the shield in the open or closed position
- fabric pouch for transport and storage included

Weight: 110 g • 3.9 oz
Material: polycarbonate
CE • EN 166 1 F • EN 172 5-2,5



1 C – X0048XX25
2 C – X0048XX29
3 C – X0048XX31

SECURE EARMUFFS



SECURE EARMUFFS 1C

The cap mounted earmuff is the ideal choice for any work that requires head and hearing protection.

- durable construction withstands rough environments
- slim design reduces the risk of snagging in confined areas
- available in three protection levels, clearly indicated with bright safety colours for easy identification and selection
- fully compatible with Safe Visor System
- universal 30 mm euro slot adaptor is compatible with most helmets on the market
- non-conductive
- smooth telescopic size adjustment
- certified with Flash helmets

Size: UNI • Weight: 250 g
SNR: 25 • NRR: 22 • SLC (80): 25
Suitable for: construction sites, engineering, forestry work, agriculture, mining
CE EN 352-3:2002

SECURE EARMUFFS 2C

Great choice for long term use in middle noise environment or for shorter use with high noise level.

The best choice for high frequency noise.
Weight: 271 g
NRR: 24 • SLC (80): 28
Suitable for: construction sites, engineering, forestry work, agriculture, mining
CE EN 352-3:2002

SECURE EARMUFFS 3C

Earmuffs suitable for extremely high noise environment.

The best choice for low oscillation frequency.

Weight: 300 g
SNR: 31 • NRR: 27 • SLC (80): 31
Suitable for: mining, car racing
CE EN 352-3:2002

XSTREAM LD

X0062XX00



Hellberg hearing protection with Bluetooth for music streaming. Your hearing is protected while you enjoy your favourite music with excellent sound quality, and the built-in speech microphone allows you to make phone calls.

- level dependent Active Listening microphones
- waterproof to IPX4
- easy to operate with push buttons
- voice assistant support
- USB charging
- battery power-save function
- fully compatible with Hellberg Safe Visor System
- certified with FLASH helmets

Technical data

- SNR: 28; NNR: 25; HML: 31-26-18
- operation temperature: -20°C / +55°C
- battery type: Li-Ion
- weight: 416 g (14.67 oz)
- Bluetooth® version: 4.1, A2DP 1.2, HSP 1.1, HFP 1.6
- run-time: 50 hours
- stand-by time: 100 hours
- charging time: 3 hours

1974 EN352-3, 4, 6, 8 • ANSI S-3.19-1974
• CSA Z94.2-02 ROHS • REACH • WEEE

LAMPFIX

W9606SX00



Lamp holder on the side of the working helmet.

- fits into universal 30 mm slot on the helmet
- suitable for the lamps with a diameter 18–23 mm (lamp not included)
- ideal with Flash helmet, compatible also with Petzl, Kask and other helmets on the market
- compatible with Hellberg hearing protection
- compatible with Cover protective eye shield also in combination with Hellberg hearing protection

Weight: 15g • 0.53 oz
Material: PA, rubber



FLASH PADDING

W9604BX00

Replacement foam padding for FLASH helmets.

- easy maintenance and replacing the padding

Weight: 6g
Material: PE



BLAST PADDING

W9608SX00

Replacement padding for the BLAST helmet.

- easy maintenance and replacing
- washable by hand or in a washing machine at 30° C

Size: UNI
Weight: 10g • 0.35 oz
Material: PES



PENTA PADDING

C0092XX

Replacement padding for the PENTA helmets

- easy maintenance and replacing
- washable by hand or in a washing machine at 30° C

Size: S, M/L, XL
Weight: 10g (M/L)
Material: PES



HEX PADDING

C0901SB

Replacement padding for the HEX helmet

- easy maintenance and replacing
- washable by hand or in a washing machine at 30° C

Size: M, L
Weight: 10g
Material: PES







HARDWARE

ANCHOR AND BELAY
DEVICES
ASCENDERS
DESCENDERS
PULLEYS
SELF BRAKING DEVICES
RETRACTABLE
FALL ARRESTERS



SIR

K032SIR00



Robust multifunctionality device for use in industrial rope access. Its functionality spans the range from rope descender and abseiling device through fall-arrest device to work positioning device for use on roofs and edges.

- unimpeded movement of the cam
- by pulling onto the working end of the rope the cam engages and jams the rope
- by pulling the lever the cam gradually releases the rope. If the lever is pulled down to its terminal position the double-stop function is triggered which blocks the rope again
- spring loaded pin for impeded swinging of the cam
- easy and intuitive installation of the device onto the rope. (watch the pictograms and read the instruction of use)
- no hidden mechanisms for easy inspection
- metal lever under all industrial conditions tested for 225 Kg according to EN 12841(rope access)

Weight: 365g • 12.88 oz
Rope diameter: 10–12mm
Working load: 225 kg

EN 341-A Singing Rock static rope
R 44 11 mm
EN 12841-C static rope 10–12mm
CE 0123



DOUBLE STOP PLUS

K031DSD00



Descender with anti-panic system in case of accidental loss of descent control.

- the descender doesn't have movable flanges. This makes it a robust and mistake-resilient device (quick insertion and release, no need to unclip it for rope insertion)
- new cam tested for higher loads – enhanced braking in both stop positions
- unique way of rope insertion. Diminished possibility of incorrect insertion of the rope. Even incorrect insertions will not result in a fall as the rope is blocked.
- sensitive and longer handle enables smooth descent without harmful rope twisting, gentle and progressive braking (enhanced press stop braking mode)
- rubberized handle provides pleasant feeling, non slip and thermal insulation.
- ergonomically improved curved edges and longer flanges provide the user with a comfortable grip with the handle
- integrated wear indicator
- high strength plain bearing added to the pivoting cam
- all parts in contact with the rope are

made of stainless steel – minimum possible wear

- rope diameter: 9–12mm
9 mm – max. rated load 130 kg
10–12 mm – max. rated load 200 kg

Weight: 421g • 14.85 oz • Breaking loads in excess of 22 kN.
Increased maximum rated load to 200 kg.
Reduced slippage of the rope to 600 daN.
Reduced force required on the handle.
CE 0123 • EN 12841 TypeC

INDY EVO PLUS

K0101BX00



Manually operated descender device with double auto-locking system, that locks both when the lever is released or when it is pressed.

INDY EVO is also a descender device (conform to EN 12841 type C) for working rope and it allows a descent at a controlled speed and stop at any time, hands free, on a static rope (EN 1891) or dynamic rope (EN 892).

It allows the lowering of two people at the same time.

Dimensions: 212x58x38 mm
 Weight: 480 g • 16.9 oz
 Rope Ø 10-12 mm (100 kg)
 Rope Ø 11-12 mm (200 kg)
 NFPA 1983 (2012 ED)
 Rope Ø 10-13 mm (one person only)
 CE 0426 • EN 341 • EN 12841



RAMA

grey – K0043SX00
 orange – K0043OX00



Intuitive single rope belay device with enhanced braking feature. Designed for gym or single pitch sport climbing.

- reliable locking geometry provides added level of safety to your belay
- operating is very simple, as it works without any moving parts or lever
- large clipping area for most common carabiner shapes, works best with BORA or OXY carabiner
- durable stainless steel braking surface provides longer lifetime and the smooth and secure control for gradual lowering
- functionality is according to the tube principle and is therefore suitable for lead and top-rope climbing
- compact geometry makes paying out rope even faster and easier, while the handle has a comfortable and firm grip.

Weight: 84 g • 3 oz
 Rope diameter: 8.7 – 11 mm
 Material: Light alloy, steel, plastic
 EN 15151-2



RAMA SET

M0201XX00

Single rope belay device with enhanced braking feature and hot-forged light alloy oval carabiner OXY TWL create a perfect set for lead or top-rope climbing.

Weight: 165 g • 5.82 oz
 Rope diameter: 8.7 – 11 mm
 Material: Light alloy, steel, plastic

SHUTTLE

K6140EE00
black matt – K6140BB00



Belay and rappel device

One device to do it all, the Shuttle offers maximum versatility. It has a groove, designed and shaped to provide equal friction for both thin and thick ropes.

When you're belaying from above, the "guide mode" lets you bring up one or two seconding climbers under control. For lowering, it has a small secondary hole that you can clinch carabiner or sling to release the device.

- designed for twin, half and single ropes
- lightweight and compact
- V-grooves for high friction when belaying the leader or rappeling
- only 65 g – one of the lightest belay devices on the market
- self locking function when belaying the second
- eye for releasing the weight
- possibility of simultaneous belaying two climbers
- weight: 65 g • 2.29 oz
- material: light alloy

Rope diameter:
 ①/2 7,8 – 10,5 mm
 ① 9 – 10,5 mm
 EN 15151-2



BUDDY

K6132EE
black matt – K6132BB



Light and compact belay tube.

For all-round climbers.
 Designed for ropes 7,8 – 11 mm
 mix color • 54g • 1.91 oz

EN 15151-2



FIGURE 8 L

K6031EE
black matt – K6031BB



Designed for ropes of bigger diameters.

30 kN • color mix • light alloy • 125 g • 4.41 oz

- for ropes of various diameters
- easy rappelling
- effective heat distribution

EN 15151-2

FIGURE 8 M

K6021EE
black matt – K6021BB



Designed for ropes of smaller diameters.

25 kN • color mix • light alloy • 104 g • 3.67 oz

EN 15151-2

RESCUE FIGURE EIGHT

light alloy – K6180BB



Special figure eight for the rescue situations and fast rappeling

Strength: 40 kN

Material: light alloy

Weight: 154 g • 5.43 oz

LIFT

LEFT – RK804BX0L
RIGHT – RK804BX0R



Hand ascender for safe and smooth ascent. Extra wide handle and attachment point for two carabiners will fit everyone from bigwall climbers to workers at height or special forces.

- available in two variants – for left and right hand
- stainless steel toothed cam for higher corrosion resistance and for any conditions (frozen or dirty ropes)
- overmolded grip and ergonomic upper part for a comfortable and powerful grip
- wide lower hole allows to connect two standard carabiners

- upper hole for clipping a carabiner around the rope
- trigger with a short descent feature

Weight: 190 g • 6.7 oz

Material:
body – light alloy
cam – stainless steel
trigger – plastic

EN 12841 Static rope Ø 10–13 mm
EN 567 Rope Ø 8–13 mm
€€ 1019 • EN 567 • EN 12841 type B

FOOT LIFT

Left – RK807BX0L
Right – RK807BX0P



Foot ascender to improve rope ascending in a rope access. Used in conjunction with LIFT and CAM CLEAN.

- stainless steel toothed cam for higher corrosion resistance and for any conditions (frozen or dirty ropes)
- cam / lever mechanism fully integrated into the body
- durable construction with stainless cast steel
- fully adjustable webbing to achieve the best comfort of use

- lower part is reinforced with tubular webbing for longer use
- quick and easy to adjust with O ring
- marked with unique production number
- for use with Ø 8-13 mm ropes, static and dynamic
- available in left and right version
- Foot Lift is not a PPE

Weight: 160 g • 5.6 oz

Working load: 120 kg
Material: light alloy, steel, plastic

CAM CLEAN

RK805BX00



Compact and lightweight chest ascender for safe and smooth rope ascent, rescue and special rope techniques.

- simple and quick manipulation
- lower hole angled to keep flat position on the harness
- stainless steel toothed cam for higher corrosion resistance and for any conditions (frozen or dirty ropes)
- Upper hole for attaching a PULLER shoulder strap to keep the rope clamp in a correct position
- trigger with a short descent feature

Weight: 125 g • 4.4 oz

Material:
body – light alloy
cam – stainless steel
trigger – plastic

EN 12841 Static rope Ø 10–13 mm
EN 567 Rope Ø 8–13 mm
€€ 1019 • EN 567 • EN12841 type B

STRAP FOR CAM CLEAN

W0085BB00



Strap for CAM CLEAN attachment to full body harnesses including plastic cover on the carabiner.

Weight: 15 g • 0.53 oz



PULLER

S1100BY

**Accessory webbing for chest ascender fixation**

- fixes chest ascender in right position
- fixed by accessory sling or a mailon carabiner to front/back
- attachment point on the harness

Color: black
Size: UNI
Width: 25 mm



LOCKER

W1010BB09

**Guided type fall arrester and work positioning device for 11 mm textile ropes (recommended Singing Rock Static 11).**

- Construction of the device allows to release it even when it is loaded
- parking cam for blocking in required position
- unopenable version together with 11 mm sewn-in rope available as SITE – work positioning lanyard
- unique production number

Color: black matt
Weight: 240 g • 8.5 oz
CE 1019 • EN 353-2 • EN 12841

LOCKER SLING

W1015B020

**Certified sling for connection the LOCKER with your harness**

Length: 20 cm • Width: 20 mm
Strength: 22 kN

CE 1019 • EN 354 • EN 566

BACK-UP

K04000BB

**Fall arrester that follows the user in both directions and stops the possible fall**

- safe and simple to use with one hand only
- shifting the special button on the lock mode, it can be used also as a positioning device or a normal locking device
- supports also the strongest stress in semi dynamic way and it avoids the shocking effects on the ropes caused by the traditional self-locking devices with toothed cams

- connector included
- it can be used also as a positioning device or a normal locking device by shifting the special button on the lock mode.

Weight: 205 g • 7.23 oz (without connector),
420 g • 14.82 oz (connector included)
Rope diameter: 10-12 mm
EN 353-2 • EN 358 • EN 567 • EN 12841 A/B
CE 0426

PULLEY TWIN

 RK802EE00
 black version – RK802BB00

Large double pulley for textile ropes for those who need great hauling efficiency, durability and still lightweight pulley.

- designed and optimized for use with a Prusik friction knot or any clamps
- sealed ball bearing and large diameter of the sheave provides great efficiency 94%
- top attachment point accepts up to three carabiners
- durable and lightweight high-efficiency single pulley for industrial use and hauling systems
- formed side plates provides protection of rope against contact with a surrounding
- fixed-by-forging sheave and anti dust cover of ball bearing provides great lifespan

- side plate holes enable cleaning of the ball-bearing surrounding

bottom attachment point: 12 kN
 strength: 36 kN
 working load: 4x3 kN
 max. Ø rope: 13 mm
 static and dynamic ropes
 sheave: aluminium alloy
 side plates: aluminium alloy
 sealed ball bearing: steel
 axle: stainless steel
 weight: 421 g • 14.9 oz
 unique production number
 €€ 1019 • EN 12278

PULLEY EXTRA

 RK801EE00
 black version – RK801BB00

Large single pulley for textile ropes for those who need great hauling efficiency, durability and lightweight pulley.

- durable and lightweight high-efficiency single pulley for industrial use and hauling systems
- sealed ball bearing and large diameter of the sheave provides great efficiency 94%
- designed and optimized for use with a Prusik friction knot or any clamps
- top attachment point accepts up to three carabiners
- formed side plates provides protection of rope against contact with a surrounding
- fixed-by-forging sheave and anti dust cover of ball bearing provides great lifespan

- side plate holes enable cleaning of the ball-bearing surrounding

strength: 32 kN
 working load: 2x3 kN
 max. Ø rope: 13 mm
 static and dynamic ropes
 sheave: aluminium alloy
 side plates: aluminium alloy
 sealed ball bearing: steel
 axle: stainless steel
 weight: 257 g • 9.1 oz
 unique production number
 €€ 1019 • EN 12278

PULLEY EXTRA PLUS

 RK808OS00
 black version – RK808BB00

Large pulley for those who need great hauling efficiency, durability and light weight.

- durable and lightweight single pulley for industrial use and hauling systems
- for use with static and dynamic textile ropes
- sealed ball bearing and large diameter of the sheave provide great efficiency 94%
- designed and optimized for use with Prusik friction knot or any clamps
- top attachment point accepts up to three carabiners
- formed side plates provide protection of rope against contact with a surrounding
- fixed-by-forging sheave and anti dust cover of ball bearing provide great lifespan
- side plate holes enable cleaning of ball bearing surrounding

- bottom attachment point strength 32 kN
- unique production number marking

Strength: 32 kN
 Working load: 2x3 kN
 Material Composition: 78% Light alloy, 21% steel, 1% plastic
 Max. Ø rope: 13 mm static and dynamic ropes
 Sheave: aluminium alloy
 Side plates: aluminium alloy
 Sealed ball bearing: steel
 Axle: stainless steel
 Weight: 276 g • 9.7 oz
 €€ 1019 • EN 12278

TANDEM PULLEY

RK803BB00



Double pulley for Tyrolean traverses and zip-lines with two stainless steel sheaves for both textile ropes (13 mm) and steel wire cables (12 mm).

Each sheave is equipped with a pair of sealed ball bearings for great durability. Hard aluminium alloy body is balck anodized and protects the sheaves from damage. Large attachment point can accommodate up to three carabiners. Second attachment point for back-up carabiner or tackle systems building.

strength: 25 kN
max. \varnothing rope: 13 mm
static and dynamic ropes
12 mm steel cable
Sheave: stainless steel
side plates: aluminium alloy
sealed ball bearing: steel
axle: stainless steel
weight: 290 g • 10.2 oz
unique production number

CE 1019 • EN 12278

PULLEY SMALL

RK800EE00

black version – RK800BB00



Small pulley for textile ropes for those who occasionally need to build simple hauling systems or manipulate with the objects.

- lightweight single pulley for hauling and rescue
- brass self lubricating bearing ensures reliable efficiency up to 81%
- suitable for use with a Prusik friction knot

strength: 22 kN
max. \varnothing rope: 13 mm
static and dynamic ropes
sheave: aluminium alloy
side plates: aluminium alloy
axle: stainless steel
friction bearing: brass
weight: 92 g • 3.3 oz
unique production number
CE 1019 • EN 12278

PULLEY MIKY

RK806BB00



Lightweight pulley with two attachment holes Designed for tree climbing application. Suitable for use with Prusik friction knot.

- two attachment holes with strength 28 kN
- anodized aluminum alloy side plates
- aluminum alloy sheave for textile ropes and auxiliary cords up to 13 mm in diameter
- bronze self lubricating bearing ensures reliable efficiency up to 81%
- unique production number marking

Weight: 105 g (3.7 oz)Material: sheave and side plates - aluminium alloy, bearing - bronze, axle - stainless steelStrength: 28 kNMax. diameter of rope: 13 mmBearing: friction
CE 1019, EN 12278

EASY LIFT

RK809SO00



Rescue pulley for cableway evacuation.

- designed to connect directly on the carrying steel cable of the cableway
- it is used during rescue operations and is used for the rescuer's crossing from the cableway support to the seat/cabin and rescued persons
- thanks to two sheaves construction it does not jump even on a rough steel cable
- lighter about 50 g than previous Easy Lift
- bigger gate opening allows to use the pulley on a thicker rope and more massive seat feet, eg. six seat cableways
- for steel rope with max. diameter 60 mm
- marked with a unique production number for better traceability and inspection

Weight: 1350 g • 3 lb
 Strength: 30 kN
 Max. diameter of steel rope: 60 mm
 Max. speed: 2 m/s
 Working load: max. 6 kN
 Sheave: POM
 Material: light alloy, POM, stainless steel
 CE 1017

RIGGING PLATE 3/5

RK714BB00



Aluminium alloy device for multi-point anchoring.

- provides efficient force distribution at different load directions
- low profile of the plate makes the connection as short as possible
- provides plenty of attachment holes
- rounded holes allow direct attachment of the ropes and slings to the rigging plate
- all attachment points are big enough to allow locking sleeves of most carabiners passing through

Weight: 145 g • 5.1 oz
 Material: light alloy
 Strength: 50 kN • Thickness: 8 mm
 CE 1019

RIGGING PLATE 1/3

RK713BB00



Aluminium alloy device for multi-point anchoring.

- helps to organize carabiners at the anchor point
- provides efficient force distribution at different load directions
- rounded holes allow direct attachment of ropes and slings to the rigging plate
- central attachment point can accommodate up to three carabiners

- all attachment points are big enough to allow locking sleeves of most carabiners passing through

Weight: 65 g • 2.3 oz
 Material: light alloy
 Strength: 36 kN • Thickness: 6 mm
 CE 1019

RINGO

K7002BX46



Detachable ring for arborists and workers at height. Intended for semi-permanent connection. Can be loaded in any direction.

- strong and light body made of aluminium alloy
- minimum strength 20 kN in any direction
- inner diameter: 46 mm
- 10 mm clipping gap
- steel bolt
- unique serial number

Weight: 75 g • 2.6 oz
Strength: 20 kN
Gate opening (d): 10 mm
CE 1019 • EN 362

Spare part: K7003XX00 Bolt for Ringo (2 pcs)

RING

RK400BB



Load sharing rings used by a person for fall protection for work at height or mountaineering.

- anodized surface
- unique number marking
- two sizes, with inner diameter 28 or 46 mm

Weight: 39 g • 1,4 oz (28 mm), 57 g • 2,0 oz (46 mm)
Material: light alloy
Strength: 25 kN
CE 1019

PILOT R3

X0069XXR3

NEW

Pilot R3 Concrete Anchor is a reusable, safe, and secure anchorage solution for horizontal, vertical, or overhead anchoring applications.

- A rapid quick-release button allows users to easily install and remove, boosting productivity.
- Built with a rigid tri-wedge design and diamond-hard carbon coating, it enhances durability in all types of concrete applications.
- The anchor incorporates an omni-directional design allowing the connector to rotate 360 degrees, and flip back and forth 180 degrees, to increase connector compatibility.

- Secure one-hand operation with push-to-stop installation
- Cycle tested to 5,000 uses
- Corrosion-resistant stainless-steel tri-wedge design
- Forged stainless steel swivel D-Ring
- For one user only

Diameter of a hole: 20 mm (3/4")
Weight: 350 g • 12.4 oz

Material: light alloy
Strength: 22 kN
CE 0161 - EN 795:2012 Type B • ANSI Z359.18 Type A

REDBLOCK

K0006RP00



Anchor device, that extends lifetime of the rope when toppling

- ideal partner for adventure parks, rope courses and climbing gyms
- allows to be installed in two axes
- for better traceability and inspection recording the RedBlock is marked with the unique production number

Color: red
 Weight: 375 g • 13.23 oz
 Material: light alloy
 Sheave: stainless steel
 Max. diameter of rope: 12 mm
 Strength: 26 kN
 CE 1019

TWISTER

K0030OG00



Innovated rotating anchor

Placed between a load and either rope or cable, the twister avoids severe rope twisting while the load turns.

Working load: 4 kN
 Color: anthracite / yellow
 Strength: 22 kN
 Weight: 88 g • 3.1 oz
 CE 0321 • EN 354

SITE

200 cm – W1011WB02
 400 cm – W1011WB04

200 cm + K370 – W1012WB02
 400 cm + K370 – W1012WB04



The work positioning lanyard with great handling makes your work safe and efficient.

- 11 mm rope sewn-in unopenable version of LOCKER – rope clamp (fall arrester)
- rope covered with tubular webbing
- parking cam for blocking in required position
- also available with stitched-in connector in accordance with EN 362 (K370)

Weight: 560 g (with connector), 410 g (without connector)
 Length: 200 cm, 400 cm
 CE 1019 • EN 358 • EN 353-2

SITE LANYARD

200 cm – W1014WB02
400 cm – W1014WB04

**Spare part for SITE positioning system.**

CE 1019 • EN 353-2 • EN 358

- suitable only with the LOCKER device for creating your positioning lanyard
- with an unopenable version of LOCKER certified in accordance to EN 353-2 and EN 358
- 11 mm rope covered with a tubular webbing
- one end of the rope is ended by a sewed eye, the 2nd one must be ended by a safety knot (see instructions of use)



Telecommunication site inspection, Sweden •  Pavel Nesvadba

STAINLESS HANGER PLATE / WITH BOLT

10 mm RK702XX10
12 mm RK702XX12

10 mm w/bolt RK715XX10
12 mm w/bolt RK715XX12



Stainless steel hanger plates and bolts for permanent anchor points. Available in two different bolt sizes.

- recommended for outdoor, wet environment. Not recommended for aggressive environment (e.g. sea water, chlorinated pool water, chemically polluted environment, etc.)

Plate thickness: 3 mm
Bolt length: 84 mm
Length of the hole: 75 mm
Strength: 25 kN
Weight:
Hanger plate 42 g • 1.48 oz
10 mm w/bolt 112 g • 3.95 oz
12 mm w/bolt 140 g • 4.94 oz
EN 795 • EN 959

ZINC PLATED HANGER PLATE / WITH BOLT

10 mm RK704XX10
12 mm RK704XX12
10 mm w/bolt RK716XX10
12 mm w/bolt RK716XX12



Zinc plated steel hanger plates and bolts for permanent anchor points. Available in two different bolt sizes.

- recommended for indoor, dry environment

Plate thickness: 4 mm
Bolt length: 84 mm
Length of the hole: 75 mm
Strength: 25 kN
Weight:
Hanger plate 62 g • 2.19 oz
10 mm w/bolt 100 g • 3.53 oz
12 mm w/bolt 125 g • 4.41 oz
EN 795 • EN 959

GLUE IN ANCHOR

RK703XX10



Stainless steel durable permanent anchor point.

- works also in soft or pocketed stone
- smooth eye allows safe rope threading for retreat
- made of welded, grade AISI 316 stainless steel
- for drilled hole with diameter 12 mm
- recommended glue: UPM 44 or FIS 360V, resin capsule RM10

Diameter: 10 mm
Length of shaft: 80 mm
Weight: 120 g 3.18 oz
Strength: \blacktriangleright 30 kN \blacktriangleleft 25 kN
EN 959 • EN 795 Type A

D – MOBILE

A0002SS01



Door or window anchor point

- an indispensable anchor point protect against sudden falls
- the safety traverse offers in connection with the rope perfect safety solution when working in wall openings and on balcony support plates
- no tools are needed to fix the traverse in doorways, the opening of which may be up to 1100 mm wide for one person for two persons can be maximum opening up to 900 mm

- fast adjustment by pressing the pawl
- star grip to clamp the safety traverse
- bearing surfaces coated with synthetic material

Strength: 22 kN • Weight: 11 kg
Dimensions: 141 x 13 x 13 cm
CE 0123 • EN 795 Type B

VERTICAL FIXED BEAM CLAMP

X0077XX00



Fixed I-beam anchor is designed to clamp onto a vertical or horizontal I-beam to create a fixed anchor point.

- zinc plated components
- stainless Steel D-Ring Mount
- static tensile strength: 22kN
- maximum capacity 140kg when used as a single point anchorage

Span: 100–350 mm
 Maximum load: 140 kg
 Weight: 3105 g • 109.5 oz

Strength: 22 kN
 CE 0321 • EN 795:2012 • ANSI Z359.18
 • ANSI Z359.7 • OSHA 1910.66/
 • OSHA 1926.503

SNAKE BRACE

S 300 – W2018Y030
 S 600 – W2018A060



Anchor point for through holes, designed to function as a link between the structure and the fall arrest, work positioning, rope access or rescue systems.

- intended for through holes whose minimum and maximum diameter corresponds to the type of Snake Brace in relation to the actual thickness of the current structure
- the opening need not be entirely regular but the minimum diameter must be flat. There must be a minimum space for installation behind the hole
- intended for a single user
- the maximum strength can be used only if the structure in which the anchor hole is located can withstand the load in all directions
- the minimum strength of the construction should be designed according to EN 795 (if not in accordance with EN 795, the load bearing capacity may be reduced)

- Snake Brace can be loaded in any direction only if also allowed by the construction in which is anchored
- can be used only with compatible connectors with locking mechanisms according to EN 362

Strength: 18 kN
 Length: 30, 60, 90, 120 cm
 Weight: (S 300) 162 g • 5.71 oz /
 (M 300) 395 g • 13.93 oz
 Material: S – dyneema, alloy, steel /
 M – PAD, alloy, steel
 CE 1019 • EN 795 Type B

type	strength	hole Ø min. (mm)	construction thickness (mm)						min. open space behind the hole (mm)
			>5	≥ 50	≥ 100	≥ 150	≥ 200	≥ 300	
			hole Ø max. (mm)						
S	18 kN	17,7	50	65	75	80	85	90	≥ 200
M	18 kN	22	175	195	210	225	235	255	≥ 450

BANTAM BEAMER

X0075XX14



Removable anchor point for construction girders

- designed for fall protection and rope access work positioning
- lighter, smoother, and easier to use
- constructed with lightweight aircraft aluminum bars and 360° swivel D-ring connection
- the clamps attach without tools to construction girders either overhead or underfoot
- intended for one person only

Span: 89 - 355 mm
 Strength: 22 kN
 Weight: 1504 g • 3.3 lb
 CE 0161 • EN 795:2012 Type B • ANSI Z359.18
 Type A • ANSI Z359.7-2019 • OSHA 29 CFR 1926.502 • OSHA 29 CFR 1910.140



RETRACTABLE TYPE FALL ARRESTERS:

This part of your safety system allows you to move freely within a certain distance during your work and absorbs the impact in the event of a fall. All devices are certified according to EN 360:2002, some of them are suitable for rescue purposes according to EN 1496:2007. SRL (self-retracting lanyard) devices are self-retractable, while winches are manually operated.

IKAR line is an ultimate hi-end range with a variety of solutions to cover all possible needs. These sturdy, low-maintenance height safety devices with webbing or galvanized steel lifeline are offered mainly in aluminium case featuring a rotational attachment swivel to better ergonomics and long lifetime. IKAR devices function in any location position and have been

tested in a simulated fall trial over an edge according to CNB 11.060 2008 sharp edge type A (with exception of HRA series). Connectors incorporate a fall indicator for easier inspection.

IKAR HWB

IKAR HWB 1.8 – A4000W018
IKAR HWB 2,8 – A4000W028
IKAR HWB 3.5 – A4000W035



Retractable fall arrester with webbing lifeline and built-in shock absorber featuring rotating attachment point and double action connector.

- lightweight aluminium housing with a webbing lifeline
- swivel eye attachment point
- sewn in load indicator on lifeline
- additional testing against falls over edges ($r \geq 0,5\text{mm}$)
- light alloy double action hook on end of lifeline
- device can be attached to an anchorage point or safety harness

- HWB 1.8 can be used as protection against falls in working cages of lifting platforms under specific conditions

Weight: 0.7 kg / 0.8 kg / 1.1 kg
Length: 1.8 m / 2.8 m / 3.5 m
Working load: 136 kg
CE 0229, EN 360

IKAR HWS

IKAR HWS 6 – A4000S060
IKAR HWS 9 A4000S090

IKAR HWS 12 – A4000S120
IKAR HWS 24 – A4000S240



Self-retractable arrester featuring a rotating attachment swivel and a connector with fall indicator and double action swivel hook.

- lightweight aluminium housing with a galvanised steel cable lifeline
- swivel eye anchor attachment point
- additional testing against falls over edges ($r \geq 0,5\text{mm}$)
- light alloy double action hook on end of lifeline

Weight: 3 kg / 3.7 kg / 5.4 kg / 8.4 kg
Length: 6 m / 9 m / 12 m / 24 m
Working load: 136 kg

CE 0229, EN 360

IKAR H

 IKAR H 33 – A4002BS33
 IKAR H 42 – A4002BS42

Self-retractable arrester featuring a connector with fall indicator and double action swivel hook.

- lightweight aluminium housing with a galvanised steel cable lifeline
- fixed handle anchor attachment point
- additional testing against falls over edges ($\geq 0,5\text{mm}$)
- light alloy double action hook on end of lifeline

Weight: 18 kg / 27.2 kg
 Length: 30 m / 40 m
 Working load: 136 kg

CE 0229, EN 360

IKAR HRA

 IKAR HRA 12 – A4004BS12
 IKAR HRA 18 – A4004BS18
 IKAR HRA 33 – A4004BS33

Self-retractable arrester with built in two-way rescue/ recovery mechanism. Fall arrest device with rescue lifting and lowering facility, equipped with a recovery mechanism operated by a device mounted handle. After an arrested fall, or if the user becomes incapacitated at the bottom of a shaft, the recovery mechanism can easily be engaged by a second person to raise or lower the person to a place of safety.

- lightweight aluminium housing with a galvanised steel cable lifeline
- fixed handle anchor attachment point
- equipped with a release pin and a recovery mechanism operated by a device mounted handle
- light alloy double action hook on end of lifeline

HRA is not suitable for use over a leading edge and has not been edge tested.
 Weight: 11.5 kg / 21 kg • Length: 18 m / 33 m
 Working load: 136 kg

Weight: 7 kg / 11.5 kg / 21 kg
 Length: 12 m / 18 m / 30 m
 CE 0229, EN 360, EN 1496

PROTECTIVE SLEEVE FOR SRL

A4072YX



PVC protective covers for self-retracting lifelines.

- sealed seamless construction protects a whole SRL from precipitation or aggressive environments
- prevents scratching or damage to labels when using a SRL horizontally
- equipped with a label access transparent window for easy pre-use inspections
- available in three sizes to suit different SRLs

A4072YX02 S
 IKAR HWB 1.8; HWB 2.8
 and HWB 3.5 or similar
 A4072YX03 M
 IKAR HWS 6; HWS 9
 and HWS 12 or similar
 A4072YX04 L
 bigger fall arresters like
 IKAR HWS 24 or similar

Weight: S 160 g • M 250 g • L 400 g
 Size: S, M, L • Material: PVC
 Dimensions: S 25x40 cm • M 30x60 cm
 • L 40x70 cm



DAVIT

Davit has a modular design that allows to build a system, which would precisely fit all possible applications in every confined environment. The swivelling davit sets are free standing or attachable to walls, tanks or other entrances. A simple plug-in mechanism allows quick and purposeful installation. In order to build your davit system, order a cantilever arm, choose from a range of fixed or temporary bases and sleeves and add required consoles for IKAR HRA self-retracting lanyards or PLW winch attachment. Designed with an integrated, easy to set fall brake system and the ability to mount mechanical devices as winches and retractable fall arresters, IKAR davits provide the customer with peace of mind for years to come.

IKAR AAS-1 CANTILEVER ARM

X4005XX00



Cantilever arm with permanent angle of 49° is developed for stationary use in safety and rescue cases for two persons, as well as for lifting and lowering loads.

- built-in 3 pulley systems redirect wire ropes from attachment point of the winch and SRL to confined space entry
- Cantilever arm is made from high quality V4A stainless steel
- Suitable for fast relocation from one sleeve to another due to foldable design of 2 detachable parts – upper davit and lower mast.

- Additional attachment point provides a possibility of attaching an SRL or fall absorber with lanyard to secure a cantilever arm operator or assistant.
- Suitable for two persons with load capacity of 300 kg

Height: 2,01 m • Reach: 0,74 m
Weight: 28,7 kg

€€ 0299 • EN 795:2012 Type B
CEN/TS 16415:2013

IKAR GROUND SLEEVE

X4006XX00

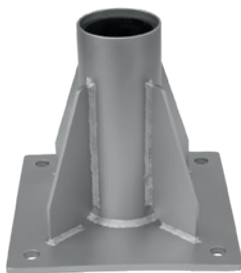

Sleeve is designed to be installed onto the ground with pivot bearing made of durable PA.

Sleeve can be mounted on existing concrete surfaces using the recommended composite anchor system Type MKT VMZ-AA4 145 M16-30 / 200 or steel constructions with screw connections M 16 grade 8.8.

Material: stainless steel 1.4571 (V4A), PA
Dimensions: 300 x 240 x 280 mm
(length x width x height)
Weight: 13,5 Kg
EN 795:2012 Type A
CEN/TS 16415:2013

IKAR WALL SLEEVE

X4007XX00



Sleeve is designed to be installed onto the wall with pivot bearing made of durable PA.

Sleeve can be mounted on existing concrete surfaces using the recommended composite anchor system Type MKT VMZ-AA4 145 M16-30 / 200 or steel constructions with screw connections M 16 grade 8.8.

Material: stainless steel 1.4571 (V4A), PA
Dimensions: 290 x 300 x 410 mm
(length x width x height)
Weight: 14,9 Kg
EN 795:2012 Type A • CEN/TS 16415:2013

IKAR LOWER GROUND SLEEVE

X4009XX00



Flush floor sleeve with 1 1/2" drainage pipe connection can be mounted to rebar before pouring concrete.

A concrete quality of at least B25 concrete must be ensured.

Material: stainless steel 1.4571 (V4A), PA
 Dimensions: 280 x 420 mm (width x height)
 Weight: 12 Kg
 EN 795:2012 Type A • CEN/TS 16415:2013

IKAR LOWER GROUND SLEEVE CORE HOLE

X4010XX00



Flush floor sleeve with 3/8" drainage pipe connection to be installed to existing concrete by core-drilling and resin fix.

A suitable shrink-free grout is PCI swelling mortar with the designation „Grout 100“.

Material: stainless steel 1.4571 (V4A), PA
 Dimensions: 160 x 335 mm (width x height)
 Weight: 4,6 Kg
 EN 795:2012 Type A • CEN/TS 16415:2013

FIXING MATERIAL FOR GROUND AND WALL SLEEVE

X4008XX00



Composite anchor system Type MKT
 VMZ-AA4 145 M16-30 / 200 for IKAR
 ground and wall sleeve.

IKAR MOBILE GROUND BASE

X4011XX00



Free standing base featuring quick and easy assembling on site.

The base consists of a central socket, height adjustable pairs or front and back legs secured with ball-lock pins. Cantilever arm rotates 360°.

Material: stainless steel 1.4571 (V4A), PA
 Dimensions: 1763 x 2228 x 450 mm
 (length x width x height)
 Weight: 23,4 Kg for central socket,
 front leg 8,1 kg each, back leg 9,2 kg each
 € 0299 • EN 795:2012 Type B • CEN/TS
 16415:2013

IKAR MOBILE ATTICS BASE

X4012XX00



Sleeve is designed to sit on the top of a concrete bund wall 200mm–400mm or container edges.

It is ideal for work areas where frequent assembly and disassembly is required.
Material: stainless steel 1.4571 (V4A)

Dimensions: 350 x 729 x 335 mm
(length x width x height)

Weight: 35 kg

CE 0299 • EN 795:2012

Type B • CEN/TS 16415:2013

IKAR WINCH CANTILEVER ARM CONSOLE

X4015XX00



Stainless steel bracket designed to fit IKAR PLW Winch to cantilever arm.

Bolts directly onto the davit's arm and comes complete with fixings and stainless-steel fixing pin for the PLW winch.

Material: aluminium

Dimensions: 200 x 130 x 82,5 mm
(length x width x height)

Weight: 2,4 kg

CANTILEVER ARM CONSOLE

IKAR HRA 12-24 – X4013XX00

IKAR HRA 33 – X4014XX00

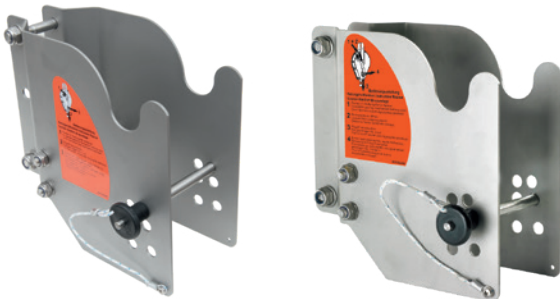

Stainless steel bracket designed to fit IKAR HRA recovery devices to IKAR Davit's mast.

Bolts directly onto the davit' mast and comes complete with fixings and stainless-steel fixing pin for the device.

Material: stainless steel 1.4571 (V4A)

Dimensions: 264 x 162 x 250 mm
(length x width x height)

Weight: 3,5 kg (5 kg for HRA 33 version)

IKAR DB-A3 TRIPOD

X4002XX00



Portable tripod with adjustable locking legs and 3 intergated pulleys. Head construction allows a variety of leg angles and a safety-chain-free design. Ideal for economical compliance in many basic confined space, fall arrest applications and rescue.

- Up to 2,54 m high aluminium tripod with corrosion-resistant coating featuring 3 bolts-in anchor points
- 1,56 m in collapsed setup for transportation, weight is 24 kg
- 2 stage independently adjustable telescopic legs with stainless steel pins and foldable rubber shoes with spiked edges. The individually adjustable legs

are advantageous as they can be used on uneven ground

- 3 pulleys built into a die casted head
- Tripod is designed to be used without support safety chain, which reduces a risk of tripping
- Suitable for two persons with load capacity of 300 kg
- Console and IKAR HRA not included

Height: min. 1,43 m, max. 2,54 m

Diameter: min. 0,64 m, max. 2,19 m

Weight: 24 kg

CE 0299 • EN 795:2012-10 Typ B • CEN/TS 16415:2013

IKAR WINCH TRIPOD CONSOLE

X4004XX00



Aluminium bracket to connect an IKAR PLW Winch to IKAR DB-A3 tripod.

Dimensions: 200 x 130 x 82,5 mm

(length x width x height)

Weight: 2.0 Kg

IKAR HRA TRIPOD CONSOLE

X4003XX00



Universal aluminium bracket to connect an IKAR HRA (up to 60m) to an IKAR DB-A3 tripod.

Dimensions: 255 x 165 x 78 mm

(length x width x height)

Weight: 1.8 Kg



IKAR PLW WINCH

A4064XX30



Hand crank winch for easy and jerk-free lifting and lowering of persons and loads according to Directive 2006/42/EG with 30 m stainless steel rope of \varnothing 6 mm (min. breaking load 18.76 kN). SWL is 300 Kg.

Material: stainless steel 1.4571 (V4A), PA
Dimensions: 230 x 336 x 200 mm (length x width x height)

Weight: 18,5 kg

CE • EN 1808:2015

EVAQ HUB II

W152IX000



Descender and rescue device with lifting function for height rescue by fire fighters, industrial climbers and others when exposed to a danger at great heights such as cable cars, outdoor parks, wind power plants or skyscrapers. Also suitable for quick and easy rescue and even for self-rescue of many threatened people. Certified according to EN 341:2011 class 1A (2 persons), EN 1496:2017 class B (2 persons), ANSI Z359.4:2013 (1 person), EN 12841:2006 Typ C (1 person)

- designed for a working load of 225 kg (2 persons)
- automatic and redundant brake system consists of 2 fly wheel brakes
- brake drums are made of steel for high resistance
- equipped with a handwheel made of durable plastic for easy and save operation even in hard conditions and under a full load
- three stainless steel eyebolts ensure smooth descend speed control and multiple operation modes
- back side rope clamp facilitates lifting operation
- to make the lifting easier the device is equipped with a 10 mm hexagon adapter for accu-drill connection

- attachment point is equipped with a steel double trigger automatic locking connector with a gate opening of 21 mm
- static polyamide kernmantle rope can be up to 500 m long
- both ends of the rope are equipped with a stitched eye and a steel double trigger automatic locking connector with a gate opening of 21 mm
- for a storage and transport we recommend a shock and waterproof plastic PROTECTIVE CASE in two sizes with a volume of 17 and 46 litres or a storage RESCUE BAG with a volume of 30 litres
- when the device is stored in a sealed protective case an annual inspection is easier without the necessity of dismantling this device. It may be carried out by a competent person.

Weight: 3.9 kg (138 oz) + rope

Working load: 30 – 225 kg (66 – 495 lb)

designed for 2 persons

Length: descent height max. 500 m (1640 ft)

Descending speed: 1,0 m/s with 85kg and

approx. 1,5 m/s with 170kg

Temperature range: -40 °C to +65 °C

CE 1019 • EN 341:2011 – 1A, EN 1496:2017 – B, EN 12841 Type C, ANSI Z359.4:2013

EVAQ ROPE

W1520X



Rope for the EvaQ II a EvaQ HUB II rescue devices

- length according to the customer's request, max. 500 m
- both ends of the rope are equipped with a stitched eye and a steel double trigger automatic locking connector with a gate opening of 21 mm

Material: polyamide

Diameter: 9.6 mm

EN 1891A

EVAQ CASE WITH SEALING

with EVAQ HUB II - W1522



Singing Rock offers devices for height rescue EVAQ II and EVAQ HUB II stored in a sealed PROTECTIVE CASE. Sealing is used to avoid laborious annual inspections of the complex rescue device. Only a visual inspection by a competent inspector without the necessity of dismantling the device is needed in case the seals are not damaged.

W1522S / EvaQ HUB II, Protective case **17**, seals – **up to 40 m of rope**
W1522L / EvaQ HUB II, Protective case **46**, seals – **40-120 m of rope**

For bigger size case option, please contact Singing Rock.

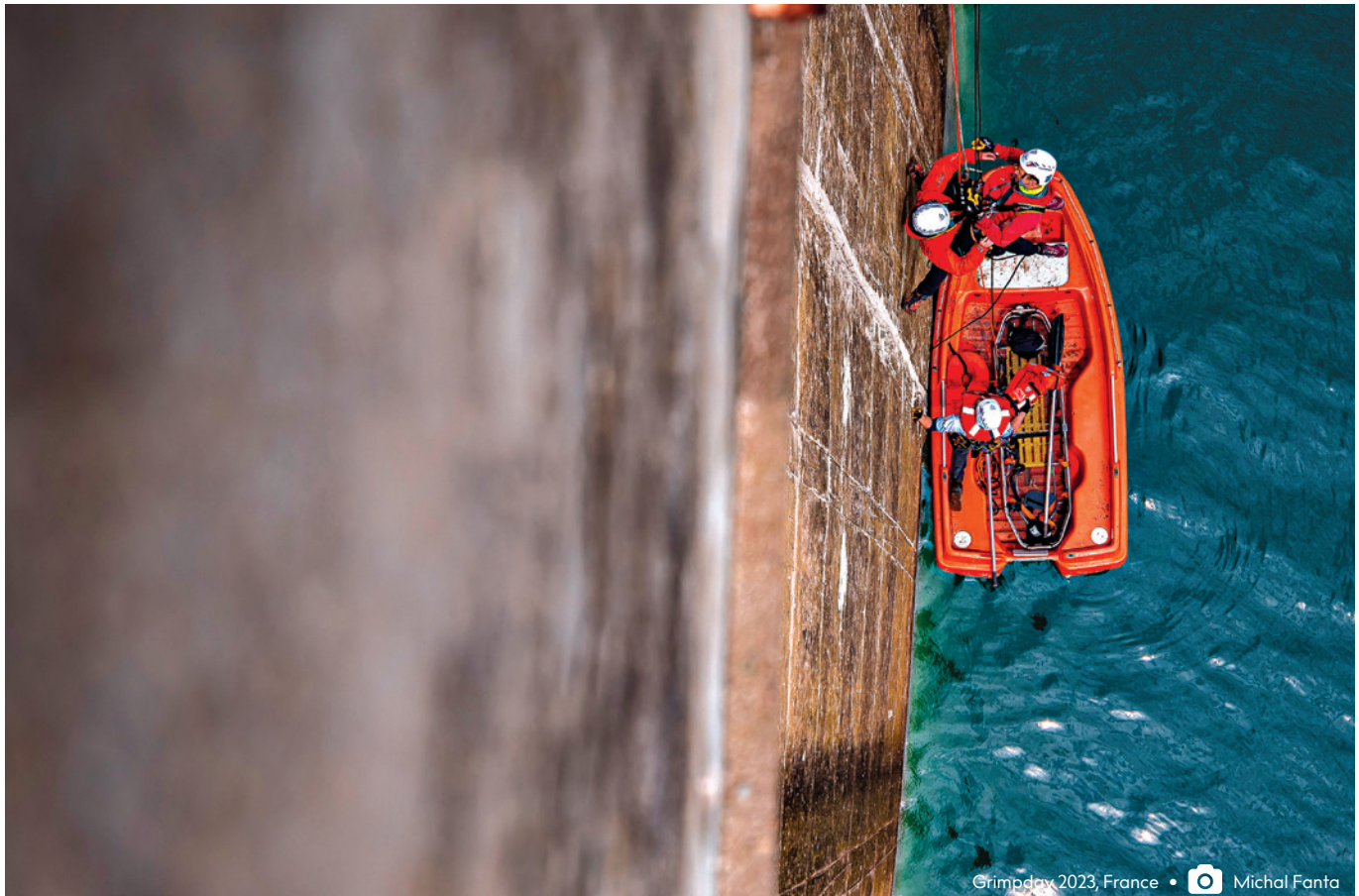

© Grimpey 2023, France •  Michal Fanta





SLINGS & LANYARDS

MOBILE ANCHORING
SYSTEM
FALL ABSORBERS



OPEN SLING 14MM

W2005

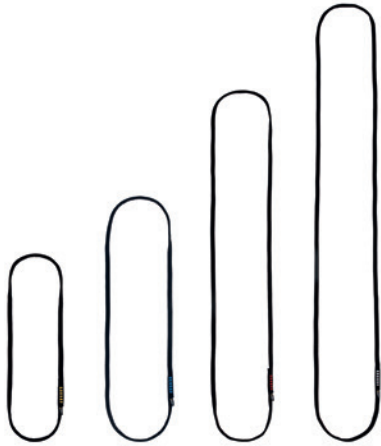

Compact sewn loop made of two-layer material.

- minimalist, strong and durable
- constructed from two parts, where the strength core is woven into the cavity
- the outer material protects the colored core, in case of damage is visible
- sewing color according to length
- suitable for anchoring and connecting when working at heights
- available also in black only (anthracite sewing)

Width: 14 mm
Strength: 25 kN
Material: 90% PES, 10% PA
Deviation in length: 60, 80 cm +/- 2 cm;
120, 150 cm -2 / + 4 cm

code	length	sewing color
W2005Y060	60 cm	yellow
W2005A080	80 cm	blue
W2005R120	120 cm	red
W2005W150	150 cm	white
W2005B060	60 cm	anthracite
W2005B080	80 cm	anthracite
W2005B120	120 cm	anthracite
W2005B150	150 cm	anthracite

CE 1019 • EN 354 • EN 795B • EN 566

OPEN SLING

W2001



Sewn sling for creating the anchor point.

Width: 20 mm
Strength: 22 kN
Length deviation: 60, 80 cm +/- 2 cm
120, 150 cm -2/+4 cm
Material: PA

	[cm]	[in]	kN	type
W2001*060	60	24	22	
W2001*080	80	32	22	
W2001*120	120	47	22	
W2001*150	150	60	22	

CE 1019 • EN 566 • EN 795B • EN 354

EYE SLING

W2004



Sewn sling from two layers of webbing and with a wear indicator.

Width: 23 mm
Strength: 30 kN
Length deviation: 60, 80 cm +/- 2 cm
120, 150 cm -2/+4 cm
Material: PA

	[cm]	[in]	kN	type
W2004*060	60	24	30	
W2004*080	80	32	30	
W2004*120	120	47	30	
W2004*150	150	60	30	

CE 1019 • EN 354 • EN 795B

SLING LANYARD

W2001



Sewn sling from two layers of webbing and with a wear indicator.

Width: 23 mm

Strength: 22 kN

Length deviation: 60, 80 cm +/- 2 cm

120, 150 cm -2/+4 cm

Material: PA

	[cm]	[in]	kN	type
W2016*060	60	24	22	
W2016*080	80	32	22	
W2016*120	120	47	22	
W2016*150	150	60	22	

CE 1019 • EN 354 • EN 795B

LANYARD "I"

W230



Lanyard „I“ for creating the anchor point or the connection device.

Available also with sewn connectors K370 and K353.

Rope diameter: 10.5 mm

Length deviation: 60,

80 cm -2/+3 cm

120, 150 cm -3/+5 cm

Strength: 22 kN

	[cm]	[in]	kN	type
W2300*060	60	24	22	
W2300*080	80	32	22	
W2300*120	120	47	22	
W2300*150	150	60	22	
W2301*060	60	24	22	K3702PP
W2301*080	80	32	22	K3702PP
W2301*120	120	47	22	K3702PP
W2301*150	150	60	22	K3702PP
W2303*060	60	24	22	K3536PP00
W2303*080	80	32	22	K3536PP00
W2303*120	120	47	22	K3536PP00
W2303*150	150	60	22	K3536PP00

CE 1019 • EN 354 • EN 795B

LANYARD "V"

W2200



Lanyard „V“ to create the connection device.

Rope diameter: 10.5 mm

Length deviation: 25/45, 25/65 cm -2/+3 cm

100/100 cm -3/+5 cm

Strength: 22 kN

	[cm]	[in]	kN	type
W2200*001	25/45	10/17	22	
W2200*002	25/65	10/30	22	
W2200*100	100/100	40/40	22	

CE 1019 • EN 354

TIMBER ACCESSORY CORD

8 mm – W2608
10 mm – W2610

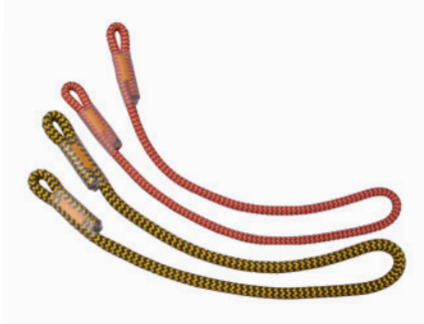

With sewn eyes.

- rope diameter 8 and 10 mm
 - the use of the PES/TECHNORA material combination results in a better thermal and mechanical resistance of the sheath
- Length:
diameter 8 mm – 75, 80, 85, 100 cm
diameter 10 mm – 80, 85, 90, 100 cm

Strength:
18 kN (8 mm)
20 kN (10 mm)

CE 1019 • EN 795B

PRUSIK SLING

8mm – W2601R085
10mm – W2602Y085

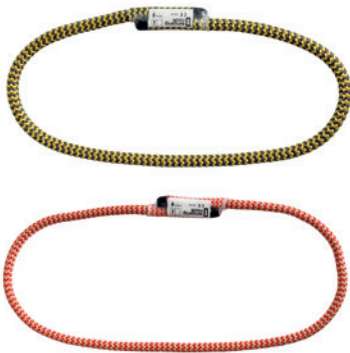

Sewed accessory cord with a diameter 8 and 10 mm for wide use at tree care and rescue operations.

- well knotted for easier work at height and for more comfortable installation of Prusik knot
- suitable also as an anchor sling, adjustment sling and for the hauling systems

Color: red/white (8 mm), yellow/black (10 mm)
Diameter: 8 and 10 mm
Length: 38 cm • 15 in
Strength: 18 kN
Working load: max. 1 person
Material: PES, Technora
Weight: 48 g • 1.7 oz (8 mm), 70 g • 2.5 oz (10 mm)

CE 1019 • EN 795B

PULLEY SLING

W2603YB00



Prusik sling with the stitched pulley SMALL for creating the anchor point.

- sling with the pulley is suitable to use as a textile blocking device for wide use mainly at the tree care and rescue operations
- spare part for BARK PULLEY SAVER
- suitable also for other work at height as an anchor point

Strength: 18 kN
Length: 40 cm • 15.7 in
Diameter: 10 mm
Working load: max. 1 person
Material: PES, Technora, light alloy
Weight: 160 g • 5.6 oz
CE 1019 • EN 795B

RING SLING

W2604RR00



Well knotted prusik sling with stitched ring with 28 mm diameter for creating the anchor point.

- sling with the ring is suitable to use as a textile blocking device for wide use mainly at the tree care and rescue operations
- spare part for BARK RING SAVER
- suitable also for other work at height as an anchor point

Strength: 18 kN
 Length: 40 cm • 15.7 in
 Diameter: 10 mm, ring 28 mm
 Working load: max. 1 person
 Material: PES, Technora, light alloy
 Weight: 115 g • 4 oz
 CE 1019 • EN 795B

JINGLE II

steel ring – W1040R
 ALU ring – W1041R
 without ring – W1042R



Cambium saver intended for use in tree climbing as anchor device and belay anchor. The different size of the rings enables easy and quick installing and removing of the sling from the ground. As well suitable in industry as an anchor device.

- length of the slings with "O" ring – 100, 120, 150 cm
- strength 25 kN
- inside and outside diameter of "O" rings:
 ALU: big 46/70 mm, small 28/52 mm
 steel: big 58/78, small 38/57

- 3 layers of webbing sewn together
- red colour of webbing for better visibility
- available with aluminium "O" rings or without "O" rings.

CE 1019 • EN 795B



Tree care in Poniklá, Czech republic • Marta Mendřická

W2113Y
ALU RING – W2111Y
STEEL RING – W2112Y

PATRON LANYARD



Dynamic rope lanyard with stitched eyes at the ends for work positioning and anchoring at the tree care.

- suitable to use with the mechanical adjustment devices and also with friction hitches (Prusik knot)
- dynamic rope 11 mm guarantees smooth adjustment and in case of fall higher impact force absorption
- strength stitching is covered with plastic cover for higher abrasion resistance and easier pulling from the tree top
- suitable also for other work at height as the anchor device
- available in 3 versions, with light alloy ring, steel ring or without a ring

Color: yellow

Strength: 22 kN

Working load: max. 1 person

Material:

PATRON LANYARD ALU RING

– PA, light alloy, PVC

PATRON LANYARD STEEL RING

– PA, steel, PVC

PATRON LANYARD – PA, PVC



Length and weight:

PATRON LANYARD ALU RING 1.25 / W2111Y125 / 125 cm • 49 in, 215 g • 7.6 oz

PATRON LANYARD ALU RING 1.50 / W2111Y150 / 150 cm • 59 in, 235 g • 8.3 oz

PATRON LANYARD STEEL RING 1.25 / W2112Y125 / 125 cm • 49 in, 292 g • 10 oz

PATRON LANYARD STEEL RING 1.50 / W2112Y150 / 150 cm • 59 in, 315 g • 11 oz

PATRON LANYARD 3.5 / W2113Y350 / 350 cm • 11.5 ft, 345 g • 12 oz

PATRON LANYARD 5.5 / W2113Y550 / 550 cm • 18 ft, 540 g • 19 oz

PATRON LANYARD 60 / W2113Y060 / 60 cm • 24 in, 105 g • 3.7 oz

PATRON LANYARD 80 / W2113Y080 / 80 cm • 31.5 in, 120 g • 4.2 oz

PATRON LANYARD 120 / W2113Y120 / 120 cm • 47 in, 155 g • 5.5 oz

PATRON LANYARD 150 / W2113Y150 / 150 cm • 59 in, 185 g • 6.5 oz

CE 1019 • EN 795B • EN 354

BARK PULLEY SAVER

W2115



Adjustable cambium saver intended for use in tree care operations.

- adjustable length and possibility to exchange the parts of the cambium saver in case of damage
- pulley sling allows smooth and fast movement in a tree top
- steel plush (22 mm diameter) with accessory cord allows to remove the cambium saver from the ground
- available in two lengths

Length: 1.25 and 1.5 m • 4 and 4.9 ft.

Weight: 470 and 495 g • 16.6 and 17.5 oz

Set includes:

- W2112 PATRON LANYARD STEEL RING
- W2603YB00 PULLEY SLING
- sheckl
- W2118XX00 retrieval plaque with accessory cord

BARK RING SAVER

W2116

**Adjustable cambium saver intended for use in tree care operations.**

- adjustable length and possibility to exchange the parts of the cambium saver in case of damage
- removing the sling with pulling ball with a diameter 32 mm or tying a barrel knot at the end of the rope
- available in two lengths

Length: 1.25 and 1.5 m • 4 and 4.9 ft.
Weight: 318 and 340 g • 11.2 and 12 oz

Set includes:

- W2112 PATRON LANYARD STEEL RING
- W2604RR00 RING SLING

ARBO SITE

W2117

**Work positioning lanyard specially intended for tree care operations.**

- allows smooth length adjustment thanks to the use of friction knots (Prusik knot) and pulleys
- the advantage of this set are two strength stitched eyes which allow to create two independent work positioning lanyards
- the set is delivered in two lengths and is ready to use
- each component is replaceable in case of damage

Work positioning set includes:

- W2117 PATRON LANYARD
- W2608 TIMBER ACCESSORY CORD
- RK806BB00 pulley MIKY
- K0122BB07 2x carabiner OXY / TRIPLE LOCK

Length: 3.5 and 5.5 m • 11.5 and 18 ft.
Weight: 638 a 860 g • 22.5 and 30 oz
CE 1019

Note: This set is not certified according to EN 358, as it consists of removable components. However, it is generally recognized according to Arboricultural Organizations (ISAs) and working practices.

TREE ANCHOR

W2114

**Connection and anchor device for work at height. Multipurpose anchor device for creating the anchor point mainly on the tree. Designed for the arborists and rescue.**

- static rope with a diameter 11 mm
- stitched steel ring (diameter 38 mm) at one rope end for variable use
- strength stitching is covered with plastic cover

Strength: 22 kN
Diameter: rope 11 mm, ring 38 mm
Working load: max. 1 person
Material: PA, steel, PVC
Length: 5 m
Weight: 525 g • 18.5 oz
CE 1019 • EN 795B • EN 354

TRACK PLUS

W1036W130



Adjustable anchoring strap and work positioning lanyard

- length adjustment from 80 to 130 cm

CE 1019 • EN 354 • EN 358 • EN 795 B

ADJUST

W1047Y100



Adjustable lanyard with steel single buckle and textile handle which allows adjusting a length under the tension.

- strong and resistant 25 mm wide webbing, eye with a protector for any EN 362 connector, big steel buckle for adjusting a length of the lanyard
- full strength textile handle for easy adjusting a length of the lanyard (guaranteed safety of this loop in case of wrong attachment)
- attachment light alloy ring with the inner diameter of 28 mm
- identification label for product traceability

Weight: 240 g • 8.5 oz
 Material: PES • Strength: 22 kN
 Width: 25 mm • 1 in
 Length: 80–145 cm • 32–57 in
 CE 1019 • EN 354 • EN 358 • EN 795 B

FLAT WEBBING

C0035AO12



- width of webbing 16 mm (0.63 in)
- made of low stretch PES
- max. length 120 m (393 ft)
- weight: 37,7 g/m
- strength: 15 kN

CE 1019 • EN 565

TUBULAR WEBBING

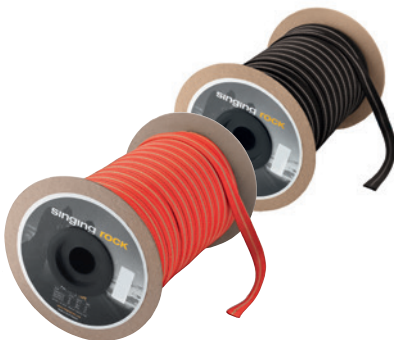
 black – C0037BB12
 red – C0037RR12

- width of webbing 20 mm (0.79 in)
- made of low stretch PES
- max. length 120 m (393 ft)
- weight: 38,2 g/m (black), 39,4 g/m (red)
- strength: 16 kN (black), 17 kN (red)

CE 1019 • EN 565

FINE LINE

MOBILE ANCHORING SYSTEM

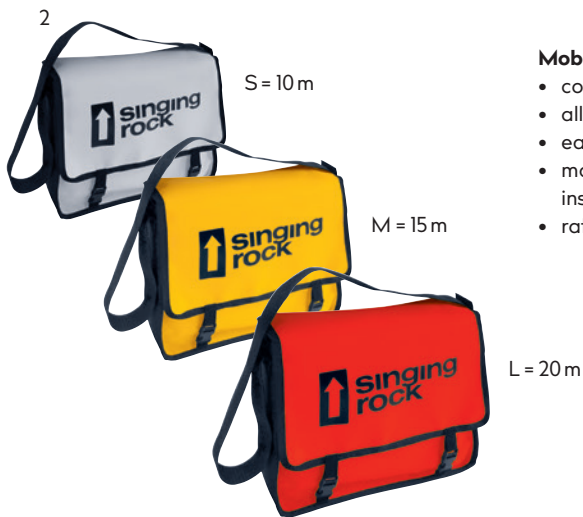

Mobile anchoring system

- colour distinction of the lengths
- allows 2 persons movement
- easy to adjust and manipulate
- manpower sufficient for fastening when installing the system
- ratchet does not damage the webbing

W1001WW10	Fine line 10 (1)
W1001WW15	Fine line 15 (1)
W1001WW20	Fine line 20 (1)
W1002WS10	Fine line bag 10 (2)
W1002WY15	Fine line bag 15 (2)
W1002WO20	Fine line bag 20 (2)

CE 1019 • EN 795 B

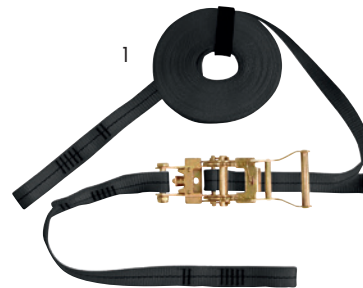

RESCUE RATCHET

W1052XX00



Quick and easy to deploy haul lanyard with ratchet for rescue purposes. It is intended to lift up the victim from the fall protection line.

Color: red
Weight: 680 g • 24 oz
Material: PES, galvanized steel
Strength: 22 kN
Width: 35 mm
Length: 25–115 cm • 31–45 in
CE 1019 • EN 354

AXILLAR

W0003BY09



Rescue sling to secure evacuated persons against accidental fall during the rescue action

(e.g. ski lift evacuation).
Weight: 385 g
EN 1498 type A



STEEL ANCHOR

300 cm – RK851XX03
500 cm – RK851XX05



Steel anchoring device ideal for tree care or welding at height.

- Steel wire cable with the diameter 6 mm is protected by thick PVC tube. Outer diameter of the tube is 13 mm.
- available in two lengths with different loop colors

Material: zinc plated steel covered by PVC
Strength: 15 kN

Length: 300, 500 cm • 9.8 ft, 16.4 ft

Weight: 730 g • 25.8 oz

1150 g • 40.6 oz

CE 1019 • EN 795B

STEEL LANYARD "I"

yellow – RK850X100
blue – RK850X130
red – RK850X180



Steel connecting and anchoring device ideal for tree care or welding at height.

- Steel wire cable with the diameter 6 mm is protected by thick PVC tube. Outer diameter of the tube is 13 mm.
- both ends finished with a fixed eye
- combination of very good strength and durability
- available in three lengths with three different loop colors
- unique production number

Material: zinc plated steel covered by PVC
Strength: 15 kN

Length: 100, 130 and 180 cm • 39, 51 and 71 in

Weight: 295 g • 10.4 oz • 350 g • 12.3 oz •

460 g • 16.2 oz

CE 1019 • EN 354 • EN 795B

JACOB DYNEEMA

C2151BY00



Versatile and ultra light ladder.

- used for aid climbing and work at height
- any cell may be loaded in any directions, which can become useful in emergency situations
- strength of each loop – 22 kN
- may be also used as an open sling for the anchoring

Length: 140 cm (55 in)
Weight: 140 g • 4.9 oz
CE 1019 • EN 566 • EN 354

JACOB

C2150BY



Ultra light six step ladder.

Steps reinforced with a plastic to hold its shape even under the load.

Maximum load: 500 kg.
Maximum load for grab loop 100 kg.
Length: 150 cm (59 in)
Weight: 210 g • 7.4 oz

FOOTER II

W1024BX
complete – W1025BX



Ascender webbing for rope access.

- big loop for easy releasing the webbing
- small loop for the attachment to the carabiner
- reinforced step loop
- FOOTER II COMPLETE is including the mini D screw connector

Min. length: 40 cm (16 in)
Max. length: 140 cm (55 in)
Weight: 90 g • 3.2 oz / 125 g • 4.4 oz (complete)
Max. load: 150 kg

FOOTER XP

W1051BX



Lightweight ascender loop made from 6 mm accessory cord.

- webbing in the buckle simplifies the length adjustment
- XP buckle allows to adjust the length even when loaded
- big hole in the buckle for the attachment with any type of carabiner
- reinforced step loop is equipped with an elastic strap which keeps the proper position of the foot

Min. length: 30 cm (12 in)
 Max. length: 170 cm (67 in)
 Weight: 105 g (3.7 oz)
 Max. load: 180 kg
 Material: PAD, light alloy

TOOL HOLDER

W1028BY00



Elastic sling to attach the tools to the harness which makes the loss of the tool impossible.

- designed to provide comfortable work while working with the tools at height
- high durability and flexibility
- steel weldet eye
- length of the sling can be extended up to 130 cm

Material: PES, PAD, steel, elastic fibre
 Load capacity: 25 kg
 Weight: 30 g • 1.06 oz
 Length: 70 cm, (130 cm fully extended)

Never use this sling for belaying!

TOOL HOLDER MAX

W1054BR00



Elastic sling for attaching heavier tools to the work harness.

- prevents tools from falling when working at heights
- stainless steel ring with 40 mm inner diameter for connection to the harness material carabiner (PORTER)
- suitable for chain saws and other tools up to a maximum weight of 10 kg

Length: 85–150 cm • 33,5–59 in
 Weight: 95 g • 3,4 oz
 Load capacity: 300 kg • 660 lb
 Material: PAD, elastic fibre, steel

REACTOR 140

W4400WW00



Shock absorber used primarily by workers on a structures, ladders and pylons.

Lightweight, practical shape does not restrict users at the work. Newly designed for users with a maximum weight of 140 kg (including equipment).

- designed to safely capture a person weighing 140 kg (including equipment)
- maximum active breaking length of shock absorber is 175 cm
- optional length of lanyards for diverse work
- zipper around the perimeter of the cover for easy inspection of the energy absorber
- intact, orange indicator of energy absorber activation

- any EN 362 certified connector can be sewn into the attachment loop
- orange indicator is threaded through the attaching loops and indicates an actual damage
- cover is made from black synthetic rubber and Cordura with PU coating
- oval shape for easy grip
- different webbing lengths are produced on customer's request

Weight: 170 g • 6 oz (without any connector and lanyards)

WLL: 140 kg

€ 1019 • EN 355



Telecommunication site, Sweden • Jan Špiroch

	Type	Code	Connector	Length [cm]	Weight [g]	RFU 11.074
	„I“ 85 cm	W4410W085		85	250	✓
		W4411W085	K370	100	400	✓
		W4412W085	K353	110	750	✓
		W4413W085	K355	120	1230	✓
	„I“ 155 cm	W4410W155		155	290	✓
		W4411W155	K370	170	440	✓
		W4412W155	K353	180	830	✓
		W4413W155	K355	190	1270	✓
	„Y“ 85 cm	W4420W085		85	210	✓
		W4421W085	2x K370	100	610	✓
		W4422W085	2x K353	110	1290	✓
		W4423W085	2x K355	120	2210	✓
	„Y“ 155 cm	W4420W155		155	390	✓
		W4421W155	2x K370	170	690	✓
		W4422W155	2x K353	180	1390	✓
		W4423W155	2x K355	190	2310	✓
	EYE „Y“ 155 cm	W4430W155		155	390	✓
		W4433W155	2x K355	190	2310	✓
	RING „Y“ 155 cm	W4440W155		155	530	✗
		W4441W155	2x K370	170	830	✗
		W4442W155	2x K353	180	1510	✗
	ROPE „I“ 85 cm	W4450X085		85	290	✗
		W4452X085	K353	110	790	✗
		W4453X085	K355	120	1260	✗
	ROPE „I“ 155 cm	W4450X155		155	370	✗
		W4452X155	K353	180	870	✗
		W4453X155	K355	190	1340	✗
	ROPE „Y“ 85 cm	W4460X085		85	400	✗
		W4462X085	2x K353	110	1400	✗
		W4463X085	2x K355	120	2340	✗
	ROPE „Y“ 155 cm	W4460X155		155	520	✗
		W4462X155	2x K353	180	1520	✗
		W4463X155	2x K355	190	2460	✗
	ADJUST	W4470Y100		100–160	420	✗
		W4471Y100	1x K370	115–175	570	✗
		W4472Y100	1x K353	125–185	920	✗
		W4474Y100	1x K0124	115–175	537	✗
	FLEX „Y“ 85 cm	W4480X085		85	330	✗
		W4482X085	2x K353	110	1355	✗
		W4483X085	2x K355	120	2255	✗
		W4484X085	2x K0124	100	565	✗
	FLEX „Y“ 155 cm	W4480X155		155	430	✗
		W4482X155	2x K353	180	1425	✗
		W4483X155	2x K355	190	2350	✗
		W4484X155	2x K0124	170	665	✗

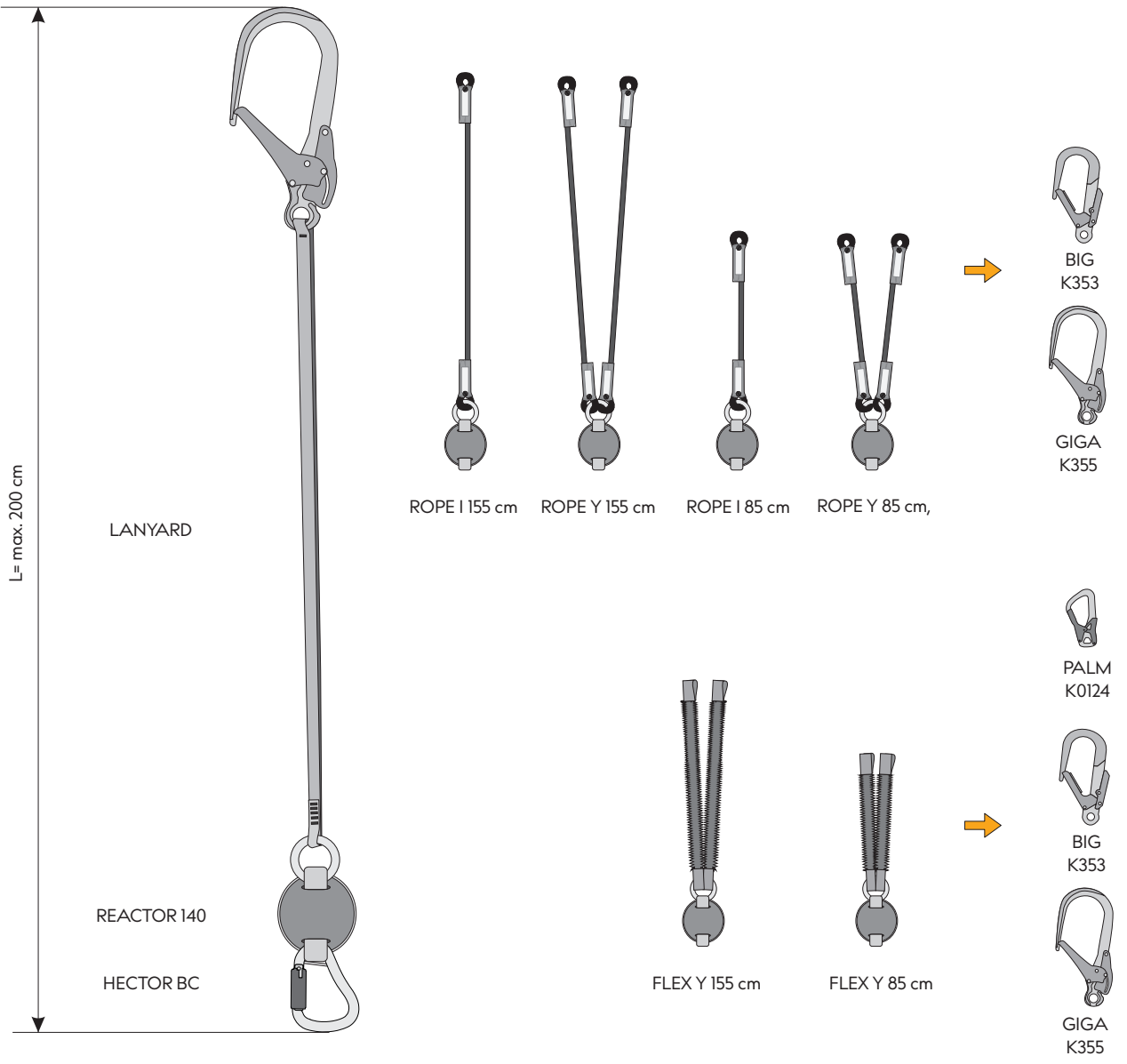
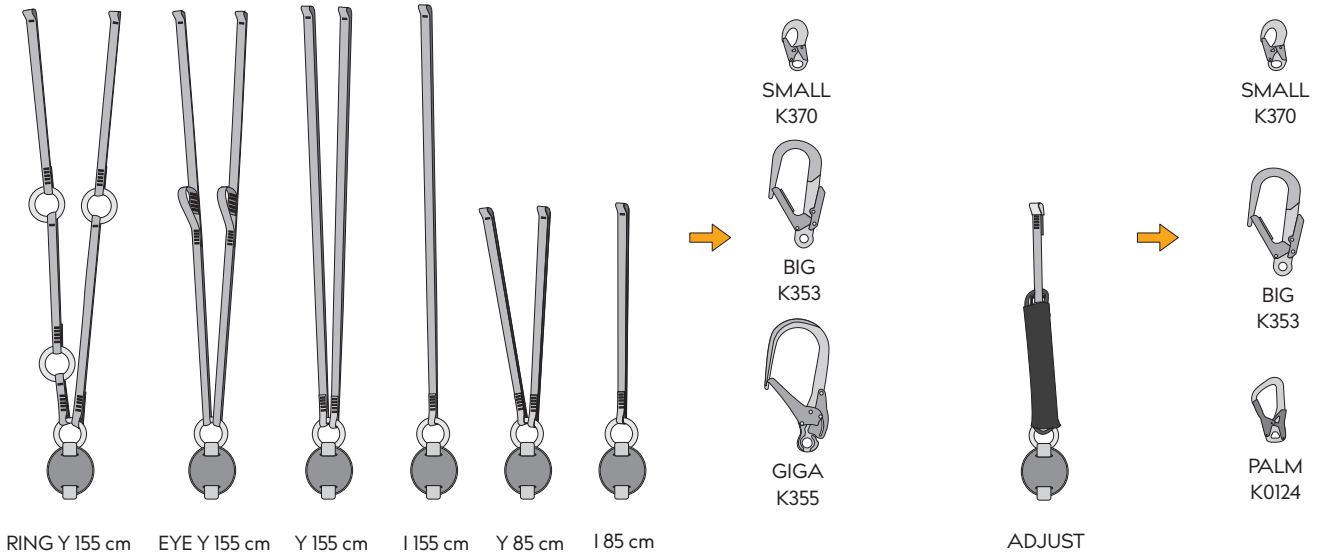

JOULE

70 cm – W4100Y070
 120 cm – W4100Y120
 160 cm – W4100Y160



Fall absorber

The fall absorber Joule presents optimal solution for securing persons working on horizontal constructions and roofs. Joule is activated after reaching the load of 2 kN (200 kg). Minimal guaranteed strength after the breaking action is 15 kN.

CE 1019 • EN 355

JOULE 70 is possible to use with the fall absorber LOCKER, for working situation which requires longer distance from the safety line.

EN 353-2, EN 355

This is not a final product, this set is necessary to set up from the separate parts.

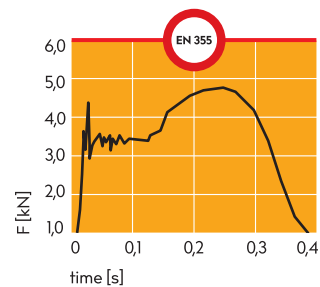

Work at height at night, Kladno, Czech Republic • Jiří Bošek

ROOFER SET

ROOFER SET 10 – M0020X1
ROOFER SET 20 – M0020X2

Roofer set is ideal for those, who are fully devoted to roofing. It allows you to position yourself on a roof with up to 45° angle to prevent a possible fall due to slippage or breaking of a structure.

Set contains:

- | | |
|-----------|--|
| W0091BY | ROOF MASTER |
| W1011WB20 | SITE – Locker+Static 11mm,
(ROFER SET 10 – 10 m,
ROFER SET 20 – 20m) |
| W2016X120 | Sling lanyard 120, 22 kN
(double safety sling) |
| K0122EE07 | OXY triple lock |
| K4241ZO07 | STEEL OVAL carabiner,
Triple Lock |
| S9000YY35 | GEAR BAG 35 L YELLOW |

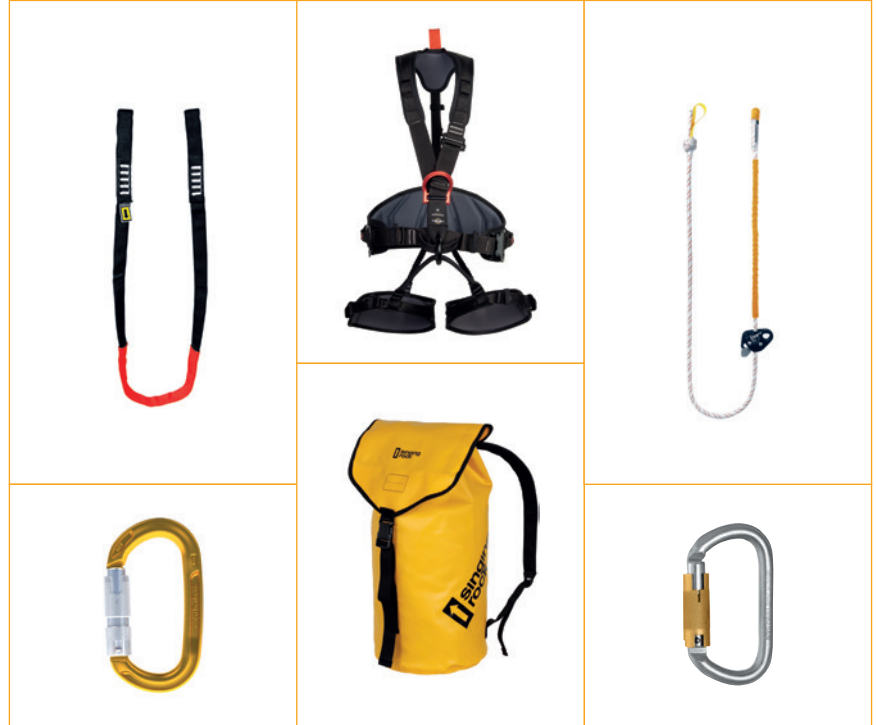

FALL ARRESTER SET

M0022XX

Set intended for work restraint situations or attaching to anchor lines. Versatile and lightweight set contains:

Set contains:

- | | |
|-----------|------------------|
| W0089SY | BASIC HARNESS |
| W4100Y160 | JOULE 160 |
| | Fall absorber |
| K4241ZO05 | STEEL OVAL |
| | CARABINER, SCREW |
| | GATE 2x |
| W0052B010 | WORKING BAG 10L |

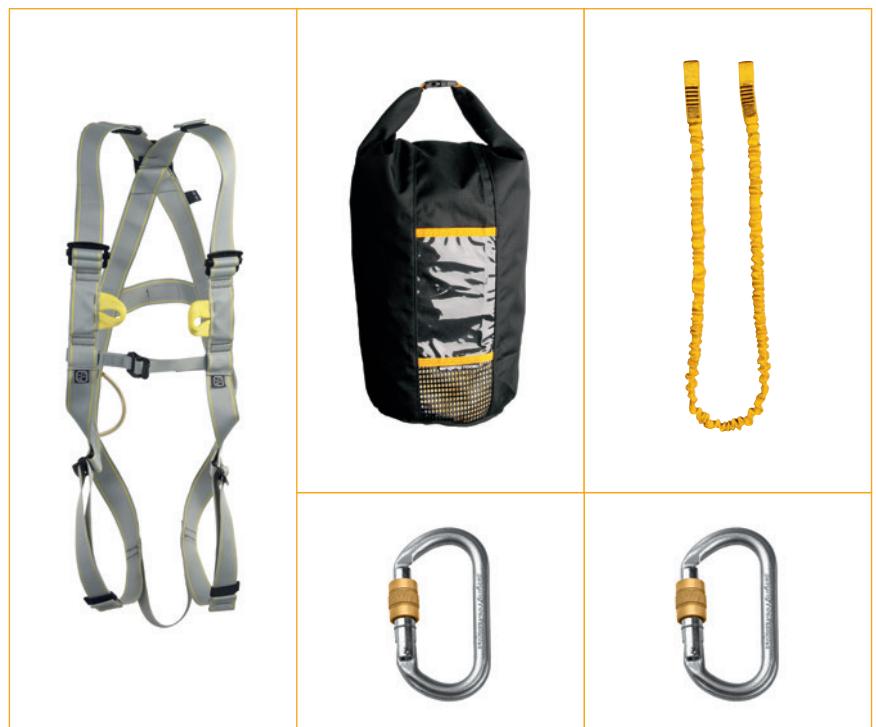

SCAFFOLDER SET

M0021XX

Scaffolder set is intended for those, who install scaffolds or work on tall structures and towers. It allows you to reach safely a place of work and position there for work.

Set contains:

W0063BB	Technic harness
W4442W155	Reactor 140 RING „Y“ 155 cm + 2xK353
W1012WB02	SITE 2M + K370
K0122EE07	OXY triple lock
K4241Z007	STEEL OVAL CARABINER, TRIPLELOCK
W1023YY00	MONTY BAG YELLOW

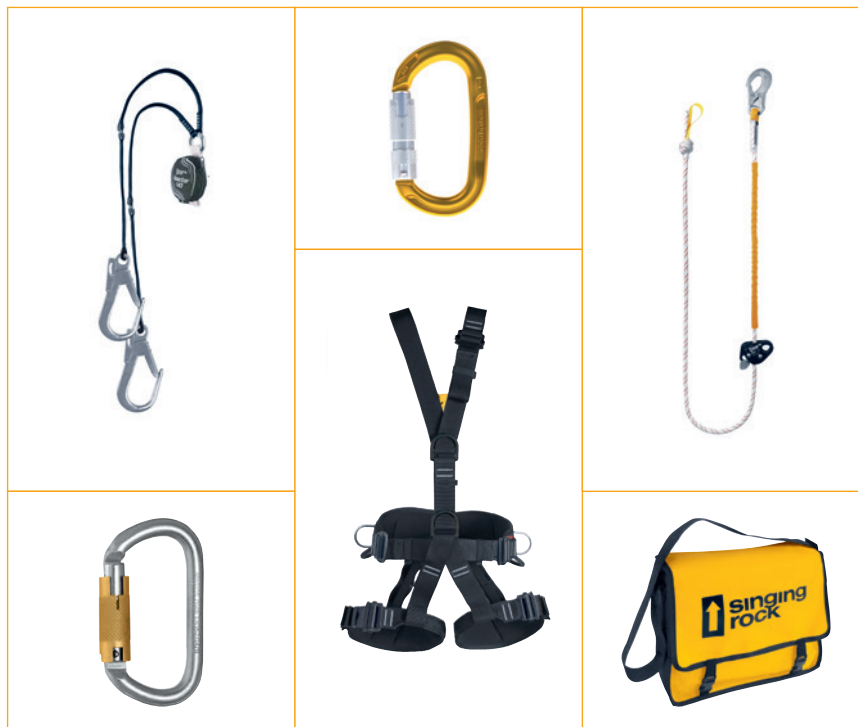

PPE INSPECTION SET

equipment for periodic PPE control

M0000XSET

W1023	Monty bag
X0013XX02	Wire (diameter 2 mm)
X0015XX00	Marker of textile PPE
X0016XX00	Gas Hot Knife
X0017XX00	Sliding Gauge
X0018XX00	Measuring Tape
X0023X200	Silicone oil
X0020XX00	Illuminated magnifier
X0004GB00	Thermocutter
L9991WB	Periodic control labels + plastic films
X0014XX00	File
X0021XX11	Sticker PPE inspection next control
X0022XX11	Sticker PPE inspection unsatisfactory



CABLEWAY EVACUATION SYSTEM

MK006

Complete evacuation set of personal protective equipment for work at heights for one rescue team carrying out the evacuation of persons from a chairlift or gondola.

- evacuation system is designed to be used by two rescuers
- set includes the EASY LIFT rescue pulley
- basic recommended gear is completed with optional equipment according to client's specific needs
- adequate knowledge of the safeguards and methodologies for using the products included in the system is essential for safe ski lift evacuation
- fulfils the Regulation EP and R (EU) 2016 / 424

CE 1017



Set includes:

fullbody harness
fall absorber Y
small maillon oval
Giga connector
HMS carabiner
Easy Lift pulley
Maillon
Figure eight

Evacuation triangle
Sling
chest sling Axillar
Static rope 11 mm
Helmet
Gear bag
Protective gloves

Additional gear according the type of cableway:

Descender
Static rope 11 mm, 5m, 2 years for descender SIR
HMS carabiner
Baby Rescue Bag
Laika - dog rescue harness



RESCUE SET

with 30 m rope – M0030X030
 with 50 m rope – M0030X050
 with 100 m rope – M0030X100

Rescue set is a perfect easy-to-use solution for rescuing the casualty from the fall arrest line and lowering him/her safely down.

Set contains:

- Rescue ratchet
- SIR
- Static R44 1l red with one stitched eye and one sealed rope end
- 1x Oval Steel Connector Triple Lock
- 1x Hector Triple lock black connector
- Maillon Big Delta
- STEEL LANYARD „I“ 130cm
- GEAR BAG red - 35l for 30 and 50 m rope, 50l for 100 m rope







ACCESSORIES & PROMOTIONAL



35 l black – S9000BB35
 35 l yellow – S9000YY35
 35 l red – S9000RR35

50 l black – S9000BB50
 50 l yellow – S9000YY50
 50 l red – S9000RR50

GEAR BAG



Transport bag for your gear

- waterproof, durable and washable
- very convenient to carry your gear
- takes up little space and stays dry
- transparent pocket (A4) on the top flap for your documents
- intended for speleology and working at heights
- minimum amount of seams
- main seams feature HF welding

Colors: yellow, red and black
 Capacity: 35 and 50 litres
 Material: PVC
 Weight: 700 g • 24.7 oz – 35 l version

TARP DUFFLE

70 litres – C0046BB70
 90 litres – C0046BB90
 120 litres – C0046B120



Tarp duffel 120 l

Tarp duffel 70,90 l

Expedition bag 70, 90, 120 l

It's not your average duffel bag... Made from a durable laminate material, the TARP DUFFLE is an almost indestructible bag. Resilient enough to be roughed up in-flight, or to be transported up a mountain via a yak or off-road vehicle, this is one burly duffel bag. For longer trips, grab the 120 litres size so you have enough room for all your gear

- Alpine-cut shoulder straps
- Dual daisy chains
- Twin haul handles on ends
- Rugged construction with extra bartacks and double stitching
- Four compression straps

- Internal mesh pockets
- Pocket on top

Capacity: 70 l, 90 l, 120 l
 Color: black
 Max. load: 20 kg, 23 kg, 23 kg
 Weight: 1820 g (70 l), 2270 g (90 l), 2720 g (120 l)
 Material: PVC

MOVEMENT BAG

C0073BY00



Resistant traveling bag with the wheels for your climbing adventures, business trips or work at height missions.

- large u-shaped opening with heavy duty double zippers provides easy access to contents. Zippers can be easily locked with a padlock
- convenient side pocket allows you to keep e.g. footwear separate from clothing
- durable webbing straps and grab handle with reinforced stitching
- smooth rolling with all-terrain wheels for effortless mobility
- durable internally constructed push button locking handle adjusts to multiple heights for comfort whether gliding or pulling the bag

- side organization pocket for all of your travel needs
- heavy-duty PVC fabric backing
- rubberized, textured corner protectors guard against wear and tear at critical contact points
- plastic piping reinforce high friction zones
- one internal accessory pocket provide easy packing organization

Dimension: 77 x 39 x 38 cm
 • 30.3 x 15.4 x 15.0 in
 Capacity: 110 litres
 Max. load: 23 kg
 Weight: 4600 g (10.1 lb)

CARRY BAG

C0001YY00



Practical bag intended for storage and transport of ropes as well as other gear.

- made from durable and washable material
- plastic reinforcements keep the bag self-standing
- due to its shape it is easy to store the rope and rigging tools properly
- very convenient to carry your gear
- reinforced ergonomic plastic handle to haul the bag
- loop on the bottom to shake out the gear and dirt
- water resistant
- side pocket for the accessories
- 2 steel rings for shoulder strap to carry the bag easily
- fast closing system

Color: yellow /black
 Dimension: 30x40(58) cm
 Max. load: 28 kg
 Capacity: 28 + 10 l
 Material: PVC
 Weight: 940 g • 33.16 oz

CUBE

W9005YB00

NEW



If you're a fan of cubes, origami, and the colors yellow and black - this is the perfect product for you! In this folding box, your throw line won't get tangled and will always be ready for use.

- tilt-up divider allows easy storage and transport of 2 throw lines
- 4 internal mesh pockets are available for storing throw bags
- interior also offers 2 velcro straps for securing the end of lines and 4 textile loops for other equipment
- free-standing construction and large opening ensure easy handling of contents
- bottom is made from water-resistant material
- reinforced seams and heavy-duty fabric sides ensures a long lifetime

- closure in folded state is secured by plastic buckles
- this box will keep your throw line kits clean and prevent their tangling during transport
- you can also use it to store other stuff in your car or workshop

Dimension: 36,5 x 36,5 x 36 cm • 14.4 x 14.4 x 14.2 in
 folded: 36,5 x 36,5 x 4 cm • 14.4 x 14.4 x 1.6 in
 Weight: 1185 g • 41.8 oz
 Volume: 48 l
 Max. load: 5 kg • 11 lb
 Color: yellow /black
 Material: PES, PVC, velcro, plastic

DRY BAG

S9001YX40 - 40 l
 S9001BX60 - 60 l



Dry bag with detachable shoulder straps intended for complete waterproof protection of your gear.

- classic rolling system with an additional guide bar
- retaining rings against unwanted opening of the closure buckle
- washable extra-durable PLASTEL® fabric, UV and waterproof resistant
- metal D-ring for safety attachment
- easily detachable foam padded shoulder straps
- color differentiation of the bag volume

Color: yellow (40 l), black (60 l)
 Weight: 750 g • 26.5 oz (± 15 g • 0.5 oz) (40 l)
 Material: PVC, PE
 Volume: 40 or 60 litres

DRY DUFFLE

40 litres, yellow – S9003YY40
60 litres, black/yellow – S9003YB60



Water resistant dry duffel that opens fully across its length so you can get to your compartment without having to unload half your stuff.

- Classic rolling system with additional guide bar
- Large top access to the compartment
- Quality fasteners to fix the closure and adjust the volume
- Daisy chain for fixing and attaching further gear
- Closure buckles on both sides to prevent unwanted opening
- Additional handle for short distance transfers
- Removable foam padded shoulder strap
- Colour differentiation of the bag volume

Color: yellow (40 L), black/yellow (60L)
Weight: 780 g • 27.5 oz (40L) 1040 g • 36.7 oz (60L)
Size: side Ø 27 cm, length 55 cm [40L] side Ø 30 cm, length 70 cm [60L]
Material: PVC, PE
Volume: 40 or 60 litres

RESCUE BAG

W9003RX45



Storage bag with a capacity of 30 litres

- ideal for long term storage of rescue equipment
- made of waterproof and washable material
- zippered transparent pocket on the side for documents/list of contents in A4 format
- adjustable shoulder strap
- fast opening/closing with a durable toggle

Weight: 1000 g (35.3 oz)
Material: PVC
Volume: 30 litres

PROTECTIVE CASE

17 litres – W9002XX17
46 litres – W9002XX46



Shock and water proof plastic box for your gear.

PROTECTIVE CASE 17 litres:

Outside dimensions

L x W x H: 40 x 30 x 22.3 cm

Inside dimensions

L x W x H: 34.3 x 22.3 x 20.5 cm

Lid + bottom depth: 3.9 + 16.6 cm

Weight: 1.74 kg

PROTECTIVE CASE 46 litres:

Outside dimensions

L x W x H: 60 x 40 x 27.8 cm

Inside dimensions

L x W x H: 51.8 x 31.8 x 25.9 cm

Lid + bottom depth: 4.8 + 21.1 cm

Weight: 3.44 kg

MONTY BAG

W1023

**Bag for your gear and documents**

- adjustable shoulder strap
- made of high resistant and durable fabric POLYMAR
- washable
- durable material
- colors: grey, yellow, orange, red

TRIPOD BAG

A4070XX00

**Durable bag with a reinforced bottom to protect a tripod from mechanical damage during transport and against weather conditions.**

- shoulder straps allow easy transport of a tripod to a workplace
- zippered top access into the bag
- durable material for higher mechanical resistance due to double-layer PVC sheath

Material: PES + PVC 600g/m²
 PES with double-layer PVC 1400g/m²
 (reinforced bottom)
 Dimension: 160 x 30 cm
 Max. load: 30 kg
 Volume: 110 l
 Weight: 2 kg - 4.4 lb

TOOLKIT

W9004YX00

**Special bag to carry fasteners and tools for work at height.**

- Belt loop to attach the toolkit to the worker at height.
- Slots for a carpenter's square.
- Closure system of the pockets to prevent falling of small items when working at heights.
- Hammer loop.
- Pockets for small items.
- Two-level loops to attach the toolkit to the harness.
- Main compartment for tools.
- Side organizer for a utility knife, a screwdriver, pencils etc.
- It is possible to carry the toolkit on a belt.

Color: yellow-black
 Dimension: 23 x 20 x 8 cm – main compartment + outside slots and pockets
 Max. load: 10 kg
 Weight: 650 g (23 oz)

TOOL BAG

W0008BS



Hardware carrier and organizer

- made of high resistant and durable fabric POLYMAR
- inside and outside pockets for hardware
- intended to be attached directly to the harness via carabiner or using additional waist belt
- well arranged
- easy to maintain
- Max. load: 10 kg
- Dimension: 23 x 23 x 9 cm



WORKING BAG

W0052B010
XL – W0052B012



Transport bag for working harnesses – also suitable as a gear bag for tools

- made from high abrasion resistant material PES 600 g/m²
- simple closing system with a plastic buckle
- net on the bottom for better airflow (the bag is not waterproof)
- transparent pocket for the name tag or instruction of use
- wide opening for easier putting in the harness or gear
- inside stitching covered by lace webbing
- suitable for 30m rope (10.0 mm)

Color: black
Weight: 125 g / 130 g • 4.4 oz / 4.6 oz
Material: PES
Capacity 10 / 12 litres

URNA

W1026BB



Leg rope bag

- for rappelling in the extreme conditions to have the rope under the control
- can be also used as a tool bag when working at the height
- easy to put on the user's leg and the harnesses with the plastic buckle
- made from high quality material
- max. length of the rope 50m of the diameter 11,5mm
- inside loop to tie the end of the rope
- easy closing system allows to feed the rope slowly

- the bag can be completely closed to avoid loosing the tools
- side pocket for small items or for the notebook

Color: black
Capacity: 11 litres
Weight: 240 g • 8.5 oz

ROPE BAG

C0001BB



With removable sheet.

- sheet dimensions 137 x 137 cm
- hidden pocket for keys and money
- well-padded shoulder straps
- abrasion resistant material

Weight: 620 g • 21.87 oz



FIRST AID BAG – LARGE

C0058RR00



(without the content)

- ideal for all of those who wish to choose -their own content
- bright colour increases the visibility in a bad weather or inside the backpack
- big attachment loop
- insert compartments in different sizes
- zipped big mesh pocket
- inside buckle with the emergency whistle
- high-durable material for the use in demanding conditions.

Dimension: 22 x 18 x 5 cm
Material: polyamid, polyester
Weight: 189 g • 6.7 oz



FIRST AID BAG

C0053RW



(without contents)

Compact and light first aid bag for minimalists

- ideal for all of those who wish to choose their own contents.
- all-round zip fastener with reflective component guarantees a good overview and easy access.
- two attachment loops;
- insert compartment in different sizes; zipped mesh pocket
- velcro attachment loop on the harness or a hip strap of backpack
- easily removable from the harness by one hand
- emergency whistle included

Dimension: 13 x 10 x 5 cm
Material: polyamid, polyester
Weight: 61 g • 2.14 oz



RESCUE POLE

W8000BX00



Retractable Pole for attaching an anchor remotely

- Remote rescues
- Pole has a 2.5 m reach
- Slim fit shoulder bag with an additional pocket for heads storage
- Available with four different heads for connectors

Weight: 390 g • 13.8 oz
 Length Extended: 250 cm
 Length Retracted: 71 cm
 Diameter: 2.8 cm
 Material: fibre glass, brass bush, PVC rubber, stainless steel heads attachment

Head for connectors:

- W0024XX01 – for BORA/HECTOR
- W0024XX02 – for BIG CONNECTOR
- W0024XX03 – for GIGA CONNECTOR
- W0024XX04 - for SMALL CONNECTOR

Heads and connectors are not included.

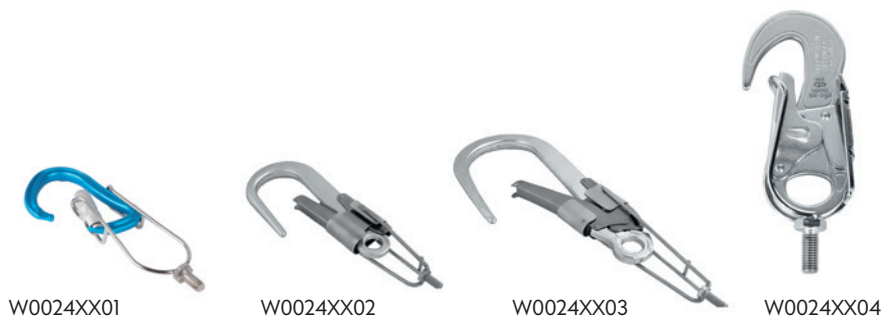

TREEMOUSE

W9500Y



Arboristic throwing bag for tree climbing

- suitable for installation of the anchor point in a treetop using cambium saver (JINGLE)
- used for dropping small branches down from the tree top
- suitable for installation of the working rope to the places with complicated access

Material: high endurance synthetic fabric PES
 steel welded ring of 3 cm in diameter
 polyamid webbing
 Colour: yellow, blue/yellow, blue

TREEMOUSE 300

300 g / yellow / code: W9500Y300

TREEMOUSE 350

350 g / blue / yellow / code: W9500Y350

TREEMOUSE 400

400 g / blue / code: W9500Y400



FALCONER FULL

C0012YB



Lightweight gloves featuring great grip, dexterity and ability.

- durable double layer of artificial and split cow grade A leather on the palm
- additional reinforcement of the high-wear area between forefinger and thumb,
- breathable abrasion resistant nylon on the back
- neoprene cuff with a reinforced attachment hole

Size: 8, 9, 10, 11
EN 420

FALCONER TACTICAL

C0013YB



Lightweight gloves with uncovered tops of thumb, forefinger and middle finger making manipulation of metalwork simpler.

- durable double layer of artificial and split cow grade A leather on the palm
- additional reinforcement of the high-wear area between forefinger and thumb
- breathable abrasion resistant nylon on the back
- neoprene cuff with a reinforced attachment hole.

Size: 8, 9, 10, 11
EN 420

FALCONER 3/4

C0014YB



Lightweight gloves with removed tops of fingers making manipulation of metalwork simpler.

- durable double layer of artificial and split cow grade A leather on the palm
- additional reinforcement of the high-wear area between thumb and index finger
- breathable abrasion resistant nylon on the back
- neoprene cuff with a reinforced attachment hole
- two special pull-off half-loops on top of middle and ring fingers to secure an easy put off.

Size: 8, 9, 10, 11
EN 420

GRIPPY

C0006BH



Made out of quality leather. Reinforced palm area. Closed fingers. Abrasion resistant.

Gloves are easy to put on thanks to special pull-on loop.

Kevlar thread • Size: 8, 9, 10, 11
EN 388, EN 420

GRIPPY 3/4

C0006HH



Made out of quality leather. Reinforced palm area and lower part of finger area.

Exposed fingertips allow you to keep your sense of touch and manipulate your gear. Gloves are easy to put on thanks to a special pull-on loop.

Kevlar thread • Size: 8, 9, 10, 11
EN 388, EN 420



Solar panel installation, Přichovice, Czechia •  Marta Mendřická

WORK KNIFE

A0031BS



Pocket knife with first class stainless steel blade.

- blade length 80 mm
- one hand operation and safety lock of opened knife
- stainless steel flexible clip for belt fixation, hole for the accessory cord fixation

Material:

blade and clip – stainless steel, plastic handle

Weight: 83 g • 2.9 oz

RESCUE KNIFE

A0030Y



Special rescue knife with first class stainless steel ejection blade.

- blade length 80 mm and safety lock of opened knife
- special shape of the blade with the hook at the end for cutting of ropes or webbing
- other features: glass cutter, hammer for glass window breaking, opener of electrical cases – wrench
- stainless steel flexible clip for belt fixation

Material:

Blade and clip – stainless steel, plastic handle

Weight: 196 g • 6.9 oz

CULTER

A0050HH00



Reliable knife for daily work or emergency situations including belt cutter and window breaker.

- half-serrated 80 mm blade made of 420B stainless steel
- handle made of stainless steel and red G10 fiber
- one hand opening and closing, safety lock
- G10 line of fiber materials is not electrically conductive

- G10 fiber exhibits superior mechanical and dimensional stability and doesn't shrink, it can also resist high temperature (up to 180 °C)

Color: red

Weight: 208 g • 7.34 oz

Material: stainless steel, G10 material

OVERALL

W9803BY



Working overall combining durability, working comfort and maximum freedom of the movement. Specially intended for work at height, easy and quick to take off even without taking the shoes off.

- 21 % polyester, 70 % cotton 250 g/ m², 9 % Cordura 500D
- bright colors and reflective strips increase the worker's visibility
- high durability even when it's washed at high temperatures (90° C)
- full-length overall with two zippers to guarantee high comfort, practicality and a high speed when putting-on
- adjustable waist for optimum working comfort
- elastic fabric in the armpits and crotch
- two large breast pockets
- on the left sleeve pocket with compartments for mobile phone, pens, small items

- on the left leg extremely large pocket for plans, gloves, etc.
- on the right leg pocket for rescue knife supplemented by two rings of rubber for protection against falling
- on the back zipper pocket for small items
- all pockets marked with bright color for greater comfort
- pants, collar and sleeves ending with adjustable Velcro against heat loss, the penetration of dirt, snow, etc.
- pants tested in the fields of work at height, rescue, arboriculture
- made in the Czech republic

Size: S, M, L, XL • EN ISO 13688

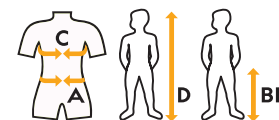

overall			
size	chest C [cm/in]	height D [cm/ft]	length E [cm/in]
S	90/35	172/5.6	102/40
M	94/37	175/5.7	105/41
L	100/39	180/5.9	110/43
XL	106/42	185/6	115/45

note: length after sewing (is added due to shrinkage), shrinkage after washing according to the processing instruction sheet is about 4% of the length

WORKING PANTS

W9801BY



Lightweight and highly flexible pants specially intended for work at heights.

- perfect combination of durability, working comfort and maximum freedom of the movement
- contrast colours and reflective strips increase the worker's visibility
- material ELASTAN guarantees a very high comfort during movement
- jeans low cut for comfortable fit
- higher back for comfortable fit with a working harness
- zippered pockets to secure any items needed in the pocket
- large zippered pocket for mobile phone or small tools, including a loop to secure tools against the fall
- in the side seam pockets for a knife, pencil, screw driver and other small tools
- on the back part deep pocket for any items
- loops for 50 mm wide belt
- large two loops for braces

- front part reinforced with CORDURA
- pants ending with adjustable velcro against heat loss, the penetration of dirt, snow, etc.
- pants tested in the fields of work at height, rescue, arboriculture
- bottoms of the pants are equipped with the mettalic hooks.

Color: black + yellow and reflexive strips

Size: S, M, L, XL

Material: 98% cotton/2% elasthan (250 g/ m²)

+ Cordura 500D
EN ISO 13688

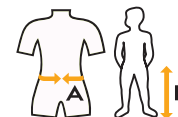

working pants		
size	waist A [cm/in]	length B [cm/in]
S	78-82/30-32	105/41
M	82-86/32-34	110/43
L	88-94/35-37	113/44
XL	96-104/38-41	115/45

note: length after sewing (is added due to shrinkage), shrinkage after washing according to the processing instruction sheet is about 4% of the length



APOLLO PANTS

CI034SS0

Men's technical pants for movement in the vertical world and for daily wear to work or school.

- the ergonomic REGULAR FIT cut with shaping at the knees and the inset gusset at the crotch guarantee maximum freedom of movement
- made of a blend of high quality cotton and spandex that guarantees breathability, durability and flexibility
- fastening of the pants with a high-quality YKK metal zipper and a metal button with the Singing Rock logo
- the possibility to tighten the width of the legs with an elastic band hidden inside the legs
- elastic band in the side seam for attaching a brush for cleaning the holds
- 2 front and 2 back comfort pockets
- the pants are finished with an enzymatic wash that makes them soft to the touch, shrunken and maximally comfortable

Size: S-XXL

Material: 96% cotton, 4% spandex

Colour: anthracite

Weight: 430 g • 15.2 oz

APOLLO SHORTS

CI035SS0

Men's technical shorts for movement in the vertical world and for daily wear to work or school.

- the ergonomic RELAX FIT cut with the inset gusset at the crotch guarantee maximum freedom of movement
- made of a blend of high quality cotton and spandex that guarantees breathability, durability and flexibility
- fastening of the shorts with a high-quality YKK metal zipper and a metal button with the Singing Rock logo
- elastic band in the side seam for attaching a brush for cleaning the holds

- 2 front and 2 back comfort pockets



- the shorts are finished with an enzymatic wash that makes them soft to the touch, shrunken and maximally comfortable

Size: S-XXL

Material: 96% cotton, 4% spandex

Colour: anthracite

Weight: 275 g • 10 oz

PANTS / SHORTS	Code	Style	Size	Color	Material	Weight g/oz	Waist width cm / in	Hip width cm / in	Thigh width cm / in	Knee width cm / in	Step length cm / in	Total length from waist cm / in	Width of leg edge cm / in
 APOLLO PANTS	CI034SS02	men's	S	anthracite	96 % cotton, 4 % spandex	420 14.82	86 33,9	101 39,8	50 19,7	45 17,7	82 32,3	105 41,3	37 14,6
	CI034SS03		M			430 15.17	88 34,7	104 40,9	55 21,7	47 18,5	82 32,3	106 41,7	38 15
	CI034SS04		L			440 15.52	89 35	107 42,1	58 22,8	47 18,5	82 32,3	106 41,7	39 15,4
	CI034SS05		XL			455 16.05	95 37,4	112 44,1	60 23,6	47 18,5	82 32,3	107 42,1	40 15,8
	CI034SS06		XXL			475 16.76	102 40,2	117 46,1	60 23,6	50 19,7	82 32,3	108 42,5	40 15,8
	 APOLLO SHORTS		CI035SS02			men's	S	anthracite	96 % cotton, 4 % spandex	265 9.35	85 33,5	101 39,8	59 23,2
CI035SS03		M	275 9.70	89 35	101 39,8		62 24,4				27 10,6	53 20,9	51 20,1
CI035SS04		L	285 10.05	92 36,2	104 40,9		63 24,8				27 10,6	53 20,9	51 20,1
CI035SS05		XL	300 10.58	98 38,6	107 42,1		63 24,8				27 10,6	53 20,9	52 20,5
CI035SS06		XXL	320 11.29	100 39,4	112 44,1		65 25,6				27 10,6	53 20,9	52 20,5

T-SHIRT BACKBONE

men – C1013BB
women – C1014BB



T-shirts made of 100% cotton with short sleeves and classic round collar.

- very comfortable to wear for daily use
- made in the Czech Republic
- tag less label

Style: men/women

Size: XS – XL

Weight: 170 g/m²

T-SHIRT ROCKET

men – C1028VX
women – C1029VX



Comfortable t-shirt made of top quality cotton with elastan, ensures the freedom of movement when climbing or wearing it everyday.

- tag less label
- relaxed fit
- made in the Czech Republic

Color: purple

Size: XS, S, M, L, XL

Material 96% cotton, 4% elastan

Weight: 170 g/m²

T-SHIRTS BLUE MOUNTAIN

men – C1032MM
women – C1033MM

Comfortable t-shirt designed by climbers for climbers. Made of top quality cotton with elasthan, keeps you moving freely at the crag or at the mountains.

- tag less label
- relaxed regular fit
- classic round collar
- made in the Czech Republic

Color: blue

Size: XS, S, M, L, XL

Material: 96% cotton,
4% elasthanWeight: 170 g/m²

POLO T-SHIRT

W9802BY



Pique style of polo t-shirt that is sure to look great with any outfit.

The polo features a regular short sleeves and collar with a three button placket for a comfortable fit. The top is finished with split sides and an embroidered Singing Rock logo for an instantly recognizable branded look.

- polo shirt with short sleeves
- regular collar
- Singing Rock branding
- machine washable

Style: UNisex

Size: S, M, L, XL

Material: 100% pique cotton

ROCKLIFE T-SHIRT LONG SLEEVE

C1036VX – man
C1037AX – woman



Comfortable long-sleeved T-shirt for your climbing activities or everyday wear in a COMFORT FIT cut in a very pleasant meliert material.

- minimalist print and woven label on the sleeve
- women's model with a deeper V-neck
- printed size label
- made in the Czech Republic

Size: S – XL (men's), XS-XL (women's)

Material: 40 % cotton, 50 % polyester, 10 % elasthan

Color: burgundy red (men's), blue (women's)

T-SHIRT COOL

W9806BX



Men's functional T-shirt made of cool material for working at heights or sports activities even on the hottest summer days.

- NILIT® Breeze® ensures a cool feeling when worn, special nylon fibres ventilate perfectly and maintain an optimal temperature
- flat seams and compression fit guarantee comfort even under the most strenuous physical work
- CoolMax fresh FX prevents overheating thanks to the active thermoregulation of the material
- T-shirt has antimicrobial protection with silver ions to slow down the decomposition of bacteria during physical activities
- made in the Czech Republic

Size: S – XXL

Material: 100 % nylon (front NILIT® Breeze®, back CoolMax fresh FX)

Color: black

T-SHIRT ACTIVE LONG SLEEVE

W9805BX



Comfortable functional long-sleeved T-shirt for cooler days when working at heights or sporting activities.

- specially developed quick-drying material and cut ensure thermal comfort during physical activities
- extended compression fit, prevents pilling during work or sports
- hybrid cut fits both men and women
- side panels ensure body temperature regulation during exercise
- flat seams guarantee wearing comfort
- T-shirt has antimicrobial protection with silver ions to slow down the decomposition of bacteria during physical activities
- made in the Czech Republic

Size: S – XXL

Material: 92% PAD supplex, 8% lycra (front and back),

92% PES, 2% PAD, 6% lycra (side panels)

Style: UNisex

Color: black

HOODY

CI018BY



Warm, cozy and comfortable hoody with a kangaroo pocket and a big hood.

Style: UNisex

Size: XS, S, M, L, XL

Material: 90% cotton,

10% soft polyester

Color: black and yellow

HOODY FULL ZIP

C1019BY – man
C1020BY – woman



Warm, cozy and comfortable hoody with two pockets, hood and full zipper

- longer sleeves and special cut for climbers guarantee maximal comfort when climbing or working at height

Style: Men, Women

Size: S, M, L, XL, XXL (XXL- man only)

Material: 90 % cotton, 10 % soft polyester

Color: black and yellow



T-SHIRT MONKEY

C1030Y



Fun, comfortable climbing t-shirts made from top quality cotton for your youngest climbing stars.

- Tagless size label
- Relaxed fit
- made in the Czech Republic

Color: yellow

Size: 116, 122, 128

Material: 100 % cotton, (170 g / m²)

KIDS HOODY

CI031M



Warm, cozy and comfortable hoody for the youngest climbers.

- fits both boys and girls
- with a kangaroo pocket and a big hood

Color: blue

Size: 116, 122, 128

Material: 90 % cotton,
10 % polyester (300 g/m²)

T – SHIRT BACKBONE JUNIOR

CI038B

NEW



Comfortable t-shirt for everyday wear, school, sports and other activities.

It combines comfort, quality and SINGING ROCK style.

- relaxed fit for boys and girls
- t-shirt features the SINGING ROCK logo on the front and back
- proudly made in Czechia guaranteeing high quality manufacturing and materials with a grammage of 170 g/m²

Color: black

Size: 140, 146, 152

Material: 100 % cotton

HOODY JUNIOR

CI039B

NEW





















Made from cosy material to keep teenagers warm and comfortable. With Singing Rock logo and distinctive arrow on the front.





- large hood protects the head from cold and wind while providing comfort and a cozy feeling
- features a handy kangaroo pocket on the belly, perfect for warming your hands
- Singing Rock logo on the back of the hoodie and a smaller logo on the sleeve
- large Singing Rock arrow on the chest

Color: black (hood yellow inside)

Size: 140, 146, 152 (unisex)

Material: 90 % cotton, 10 % soft polyester

T- SHIRTS		Code	Style	Size	Color	Material	Back length cm / in	Front length cm / in	Chest width cm / in	Waist width cm / in	Bottom width cm / in	Leeve circumference cm / in	Sleeve length cm / in	Neck width cm / in
BLUE MOUNTAIN 		C1032MM02	men's	XS	blue	96 % cotton, 4 % elasthan (170 g/m ²)	65 25,6	65 25,6	93 36,6	90 35,4	88 34,7	27 10,6	34 13,4	22 8,7
				S			65 25,6	65 25,6	98 38,6	96 37,8	96 37,8	29 11,4	34 13,4	24 9,5
				M			68 26,8	67 26,4	104 40,9	102 40,2	102 40,2	32 12,6	37 14,6	24 9,5
				L			71 28	70 27,6	110 43,3	107 42,1	107 42,1	32 12,6	37 14,6	25 9,8
				XL			72 28,4	71 28	116 45,7	112 44,1	112 44,1	35 13,8	38 15	25 9,8
BLUE MOUNTAIN 		C1033MM02	women's	XS	blue	96 % cotton, 4 % elasthan (170 g/m ²)	58 22,8	58 22,8	73 28,7	67 26,4	80 31,5	29 11,4	18 7,1	22 8,7
				S			59 23,2	59 23,2	77 30,3	69 27,2	87 34,3	30 11,8	20 7,9	24 9,5
				M			61 24	61 24	83 32,7	77 30,3	92 36,2	30 11,8	20 7,9	26 10,2
				L			62 24,4	62 24,4	92 36,2	84 33,1	101 39,8	32 12,6	23 9,1	26 10,2
				XL			64 25,2	64 25,2	96 37,8	88 34,7	106 41,7	33 13	24 9,5	28 11
ROCKET 		C1028VX02	men's	XS	purple	96 % cotton, 4 % elasthan (170 g/m ²)	66 26	66 26	93 36,6	89 35	89 35	35 13,8	28 11	22 8,7
				S			66 26	66 26	95 37,4	93 36,6	93 36,6	35 13,8	28 11	24 9,5
				M			68 26,8	68 26,8	103 40,6	100 39,4	100 39,4	35 13,8	31 12,2	24 9,5
				L			70 27,6	70 27,6	108 42,5	105 41,3	106 41,7	35 13,8	32 12,6	26 10,2
				XL			74 29,1	74 29,1	113 44,5	110 43,3	110 43,3	37 14,6	34 13,4	26 10,2
ROCKET 		C1029VX02	women's	XS	purple	96 % cotton, 4 % elasthan (170 g/m ²)	60 23,6	60 23,6	74 29,1	69 27,2	82 32,3	29 11,4	18 7,1	22 8,7
				S			60 23,6	60 23,6	78 30,7	73 28,7	88 34,7	30 11,8	19 7,5	26 10,2
				M			62 24,4	62 24,4	85 33,5	77 30,3	93 36,6	30 11,8	19 7,5	26 10,2
				L			64 25,2	64 25,2	90 35,4	82 32,3	100 39,4	32 12,6	21 8,3	28 11
				XL			68 26,8	68 26,8	94 37	85 33,5	105 41,3	32 12,6	24 9,5	28 11
BACKBONE 		C1013BB01	men's	XS	black	100 % cotton	67 26,4	66 26	89 35	91 35,8	94 37	30 11,8	30 11,8	23 9,1
				S			69 27,2	68 26,8	100 39,4	101 39,8	103 40,6	32 12,6	35 13,8	25 9,8
				M			71 28	70 27,6	107 42,1	107 42,1	110 43,3	34 13,4	35 13,8	25 9,8
				L			72 28,4	71 28	115 45,3	115 45,3	120 47,2	38 15	38 15	26 10,2
				XL			75 29,5	74 29,1	125 49,2	125 49,2	128 50,4	39 15,4	38 15	26 10,2
BACKBONE 		C1014BB01	women's	XS	black	100 % cotton	60 23,6	60 23,6	73 28,7	69 27,2	83 32,7	28 11	23 9,1	24 9,5
				S			62 24,4	62 24,4	77 30,3	75 29,5	90 35,4	30 11,8	23 9,1	26 10,2
				M			65 25,6	64 25,2	86 33,9	80 31,5	95 37,4	32 12,6	25 9,8	26 10,2
				L			69 27,2	68 26,8	90 35,4	86 33,9	100 39,4	32 12,6	25 9,8	28 11
				XL			69 27,2	68 26,8	96 37,8	91 35,8	105 41,3	33 13	27 10,6	29 11,4
BACKBONE JUNIOR 		C1038B140	children's	140	black	100 % cotton	50 19,7	50 19,7	74 29,1	74 29,1	76 29,9	30 11,8	21 8,3	20 7,9
				146			51 20,1	52 20,5	77 30,3	77 30,3	79 31,1	32 12,6	23 9,1	20 7,9
				152			55 21,7	56 22	78 30,7	80 31,5	82 32,3	32 12,6	23 9,1	22 8,7
MONKEY 		C1030Y116	children's	116	yellow	100 % cotton, (170 g/m ²)	44 17,3	43 16,9	60 23,6	62 24,4	63 24,8	24 9,5	16 6,3	18 7,1
				122			46 18,1	45 17,7	64 25,2	65 25,6	66 26	24 9,5	18 7,1	18 7,1
				128			52 20,5	52 20,5	68 26,8	67 26,4	71 28	26 10,2	20 7,9	20 7,9
POLO T-SHIRT 		W9802BY02	men's	S	black	100 % cotton	72 28,4	71 28	100 39,4	97 38,2	99 39	31 12,2	30 11,8	21 8,3
				M			72 28,4	71 28	106 41,7	100 39,4	104 40,9	31 12,2	32 12,6	23 9,1
				L			74 29,1	73 28,7	114 44,9	108 42,5	114 44,9	33 13	35 13,8	26 10,2
				XL			77 30,3	76 29,9	122 48	116 45,7	120 47,2	38 15	37 14,6	26 10,2

ROCKLIFE long sleeve		C1036VX02	men's	S	burgundy red	40 % cotton, 50 % PES, 10 % elastan	68 26,8	67 26,4	96 37,8	94 37	98 38,6	25 9,8	67 26,4	18 7,1
		C1036VX03		M			69 27,2	69 27,2	102 40,2	96 37,8	102 40,2	25 9,8	68 26,8	18,5 7,3
		C1036VX04		L			70 27,6	70 27,6	106 41,7	100 39,4	106 41,7	25 9,8	69 27,2	19 7,5
		C1036VX05		XL			72 28,4	72 28,4	112 44,1	106 41,7	112 44,1	25 9,8	70 27,6	19,5 7,7
ROCKLIFE long sleeve		C1037AX01	women's	XS	blue	40 % cotton, 50 % PES, 10 % elastan	61 24	61 24	86 33,9	78 30,7	86 33,9	19 7,5	60 23,6	20 7,9
		C1037AX02		S			62 24,4	62 24,4	90 35,4	82 32,3	90 35,4	19 7,5	61 24	20 7,9
		C1037AX03		M			63 24,8	63 24,8	94 37	86 33,9	94 37	19 7,5	62 24,4	21 8,3
		C1037AX04		L			64 25,2	64 25,2	98 38,6	90 35,4	98 38,6	20 7,9	63 24,8	21 8,3
		C1037AX05		XL			65 25,6	65 25,6	102 40,2	94 37	102 40,2	20 7,9	63 24,8	21 8,3
ACTIVE long sleeve		W9805BX02	UNI	S	black	front and back: 92 % PAD supplex, 8 % lycra side panels: 92 % PES, 2 % PAD, 6 % lycra	68 26,8	66 26	94 37	74 29,1	86 33,9	19 7,5	70 27,6	20 7,9
		W9805BX03		M			69 27,2	69 27,2	100 39,4	82 32,3	93 36,6	20 7,9	71 28	21 8,3
		W9805BX04		L			69 27,2	69 27,2	111 43,7	90 35,4	100 39,4	22 8,7	73 28,7	22 8,7
		W9805BX05		XL			72 28,4	72 28,4	114 44,9	93 36,6	104 40,9	22 8,7	74 29,1	23 9,1
		W9805BX06		XXL			74 29,1	72 28,4	120 47,2	99 39	110 43,3	23 9,1	75 29,5	23 9,1
COOL		W9806BX02	men's	S	black	100 % nylon (front NILIT® Breeze®, back CoolMax fresh FX)	76 29,9	76 29,9	101 39,8	96 37,8	98 38,6	35 13,8	37 14,6	24 9,5
		W9806BX03		M			78 30,7	78 30,7	106 41,7	101 39,8	103 40,6	36 14,2	38 15	24 9,5
		W9806BX04		L			80 31,5	80 31,5	111 43,7	106 41,7	108 42,5	37 14,6	39 15,4	26 10,2
		W9806BX05		XL			83 32,7	83 32,7	116 45,7	110 43,3	113 44,5	38 15	40 15,8	26 10,2
		W9806BX06		XXL			86 33,9	86 33,9	121 47,6	115 45,3	118 46,5	39 15,4	41 16,1	26 10,2

HOODIES						Back length cm / in	Front length cm / in	Chest width cm / in	Waist width cm / in	Bottom width cm / in	Sleeve circumference cm / in	Sleeve length cm / in	Neck width cm / in	
HOODY		C1018BY01	UNI	XS	black/yellow	90 % cotton, 10 % PES	67 26,4	65 25,6	92 36,2	92 36,2	88 34,7	17 6,69	68 26,8	28 11
		C1018BY02		S			67 26,4	65 25,6	98 38,6	94 37	91 35,8	18 7,1	71 28	28 11
		C1018BY03		M			69 27,2	68 26,8	105 41,3	100 39,4	96 37,8	20 7,9	75 29,5	30 11,8
		C1018BY04		L			72 28,4	70 27,6	110 43,3	107 42,1	100 39,4	20 7,9	78 30,7	30 11,8
		C1018BY05		XL			72 28,4	73 28,7	118 46,5	114 44,9	108 42,5	20 7,9	82 32,3	30 11,8
HOODY FULL ZIP		C1019BY02	men's	S	black/yellow	90 % cotton, 10 % PES	66 26	65 25,6	109 42,9	100 39,4	87 34,3	18 7,1	73 28,7	30 11,8
		C1019BY03		M			70 27,6	69 27,2	117 46,1	107 42,1	95 37,4	18 7,1	76 29,9	30 11,8
		C1019BY04		L			72 28,4	70 27,6	122 48	114 44,9	100 39,4	18 7,1	78 30,7	30 11,8
		C1019BY05		XL			76 29,9	75 29,5	130 51,2	120 47,2	105 41,3	20 7,9	80 31,5	30 11,8
		C1019BY06		XXL			79 31,1	77 30,3	135 53,2	125 49,2	115 45,3	20 7,9	82 32,3	30 11,8
HOODY FULL ZIP		C1020BY02	women's	S	black/yellow	90 % cotton, 10 % PES	66 26	66 26	98 38,6	83 32,7	86 33,9	18 7,1	74 29,1	24 9,5
		C1020BY03		M			68 26,8	68 26,8	107 42,1	90 35,4	92 36,2	18 7,1	76 29,9	24 9,5
		C1020BY04		L			70 27,6	70 27,6	114 44,9	95 37,4	100 39,4	20 7,9	80 31,5	24 9,5
		C1020BY05		XL			72 28,4	72 28,4	120 47,2	105 41,3	108 42,5	22 8,7	84 33,1	24 9,5
HOODY JUNIOR		C1039BI40	children's	140	black/yellow	90 % cotton, 10 % PES	51 20,1	50 19,7	92 36,2	88 34,7	84 33,1	24 9,5	55 21,7	24 9,5
		C1039BI46		146			53 20,9	51 20,1	95 37,4	93 36,6	88 34,7	26 10,2	57 22,4	24 9,5
		C1039BI52		152			55 21,7	54 21,3	98 38,6	96 37,8	90 35,4	26 10,2	59 23,2	26 10,2
KIDS HOODY		C1031MI16	children's	116	blue/yellow	90 % cotton, 10 % PES (300 g/m²)	44 17,3	43 16,9	60 23,6	62 24,4	63 24,8	24 9,5	16 6,3	18 7,1
		C1031MI22		122			46 18,1	45 17,7	64 25,2	65 25,6	66 26	24 9,5	18 7,1	18 7,1
		C1031MI28		128			54 21,3	53 20,9	70 27,6	68 26,8	65 25,6	18 7,1	53 20,9	23 9,1

SNAPBACK HAT

C0074BY00



Cool Singing Rock cap for your head.

- flat bill is a classic among snapback caps
- solid crown and front panels are reinforced in perfect shape
- mesh in the back perfectly ventilates even in warmer weather
- easy adjustment with a snap strap

Weight: 94 g

Material: 65% PES, 35 % cotton, flap 100 % cotton, net 100 % Nylon

TRUCKER HAT

C0089SX00



Trucker hat for casual wear, work or climbing trips.

- mid-crown trucker hat with a six-panel design
- Singing Rock original embroidery
- adjustable snap closure

Weight: 82 g

Color: grey

Material: flap 97 % cotton / 3 % elasthan, front panel 100 % cotton, net 100 % PES

BASEBALL HAT

black – C0051BH
brown – C0051HH



Square-shaped visor. Logo on front.
Website singingrock.com on back.

BASEBALL HAT LIGHT

C0070SL00



Cool hat for hot sunny days to cool down your head.

BEANIE

BEANIE LOGOS – C0054BX
 BEANIE BLACK ARROW – C0055BX



- made from microfibre polyester fabric that keeps its shape well, as well as being breathable, warm, soft and lightweight
- keep your head warm and dry during vertical activities
- fits very well under the helmet
- suitable also for running, skiing, biking and other outdoor activities

Size: S-M, L-XL

Material: 100% Polyester

BEANIE PRO

C0087SB



Protective beanie for cold and windy conditions.

- upper part made of breathable, warm, soft and lightweight micro fiber polyester fabric
- lower section is made of windproof micro fleece fabric to protect against wind in cold environments
- fits very well under a helmet
- lateral perforations in ear areas ensure hearing during work or other activity
- machine washable up to 30° C, not suitable for tumble dry
- available in two sizes

Weight: 21g • 0.74 oz

Size: S-M (49–53 cm • 19–21 in),

L-XL (54–58 cm • 21–23 in)

Material: 100% Polyester

BEANIE POLAR

C0090BB00



Warm Polartec® Power Stretch® beanie for sport and work activities.

- made of very warm stretch functional material that can wick away sweat and is more resistant to wind and abrasion compared to conventional materials
- fits well under the helmet for all vertical activities
- flat seams do not disturb when wearing the helmet
- suitable also for other outdoor activities – skiing, snowboarding, running, etc.
- machine washable up to 30 °C, not suitable for tumble dry
- available in one size, fits men & women

Size: UNI

Material: 100% PES

BALACLAVA PRO

C0088SB



Balaclava for the ultimate protection of the head, face and neck at cold and extreme conditions.

- provides great comfort due to stretchy, breathable fabric protecting your face while wicking moisture away
- designed for wearing under a helmet during all vertical activities
- you can wear it as a balaclava, half ski mask or neck gaiter. Just don't wear it in an airport or bank!
- suitable also for skiing, snowboarding, mountainbiking
- machine washable up to 30 °C
- fits men & women, available in two sizes

Size: S-M (52-55 cm), L-XL (56-59 cm)
Material: 52% polyamide, 42% polypropylene, 6% elasthan

BEANIE HAT

C0069



C0069BG00
NANUK BLUE



C0069PB00
NANUK purple

A Wool/acrylic mix of beanies, featuring a double layered headband and embroidered design.

- fits well under the helmet
- fleece double layered headband for colder conditions

Size: UNI
Material: wool, acrylic

SCARF

BLACK ARROW – C0079BX00
LOGOS – C0080BX00

Multifunctional scarf 8 in 1 with a wide variety of uses for your protection against wind and cold.

- can be used as a balaclava, cap, mask, scarf, beanie, shawl, ear warmer, etc.
- made from elastic high-tech 100% polyester microfibre fabric that keeps its shape well, as well as being breathable, warm, soft, lightweight, of a very high quality and antibacterial.
- machine washable at 30 °C, cannot be tumble dried, air dry very quickly

Size: UNI (approx. 25 cm wide x 46 cm long)
Weight: 35 g • 1.24 oz



Wind farm Liberec, Czechia •  Ondřej Vitko

PITCHER

0.5l – P0010X050
0.3l – P0010X030



Classical beer pitcher 0.5l or 0.3l
for all who likes climbing and all activities on our vertical playground.

BEER MAT

SQUARE – P0047XX01
CIRCULAR – P0047XX02



Wooden beer mats under your favorite glass of beer or cup of tea and coffee.

- perfect way to protect the surface of your table from the wet beer mugs or coffee cups
- made of very durable, high quality birch plywood coated with transparent varnish

Weight: 50 g • 1.76 oz
Material: plywood
Thickness: 8 mm
Dimensions: 9 x 9 cm • 3.5 x 3.5 in,
Ø 10,5 cm • 4.1 in

WHOLE BEAN COFFEE CAN

P0038W150



Whole bean coffee for outdoor enthusiasts and coffee lovers. Enjoy the coffee time before/after your climbing or working day.

- whole bean coffee in a practical can, thanks to which the coffee retains its freshness and aroma
- for finest taste, always use clean, filtered water

Weight: 150 g • 5.3 oz
Coffee: 100 % Arabica

TRAVEL MUG

P0048X400



Travel Mug for your favourite coffee, tea or cold drink when you are travelling, camping or working in the office.

- keeps your drink hot or cold exactly as you need it
- BPA free no-spill top features a handy hinged lid to securely close when it's not in use
- made from durable, high-grade stainless steel that preserves the flavour and freshness of your drink
- double vacuum-insulated wall keeps the drink hot / cold for long hours, making it ideal for travel by car or other means of transport
- exterior is made from a bamboo composite material which protect your hands from the heat
- non-slip bottom, suitable for all common drink holders in the cars

Weight: 170 g • 6 oz • Volume: 400 ml • 14 fl. oz
 Height: 17 cm • 6.7 in
 Material: stainless steel, bamboo, BPA free plastic

GROUND COFFEE OUTDOOR

P0038GB10



Coffee for outdoor enthusiasts and coffee lovers. Enjoy the coffee time before/after your climbing or working day.

- each bag includes tear open inner pack which can be placed on any cup
- for finest taste, always use clean, filtered water; pour 180-200 ml, leave for 5 minutes and enjoy your coffee
- bags contain A1 and Brazil ground coffee
- A1 (80% Arabica / 20% Robusta) with strong, full, medium bitter taste with a pleasant aftertaste, suitable for milk treatments
- 100% Arabica Brazil Pergamino Sul de Minas has very well balanced delicate sweet taste with a slight acidity and a hint of chocolate and almonds
- packet includes 5 bags of A1 coffee blend and 5 bags of 100% Arabica Brazil (marked with a stamp on the bag)

Weight: 10 g • 0.35 oz (bag)
 Coffee: A1 (80% Arabica / 20% Robusta), Brazil (100% Arabica)

BELT

C9091XX



for trousers with Rock&Lock smart buckle

Do not use for climbing or work at heights!

Size: M/L, XL

Width: 20 mm

SPEED BELT

black – C9092BX
various colors – C9092XX



Belt for trousers with Speed buckle for fast releasing.

Width: 44 mm

Size: M/L, XL

Color: mixed colors

Do not use for climbing or work at height!

Color: black, khaki, various colors

KEY HOLDER

P99100X



You will never lose your keys if you use Singing Rock key holders.

USB FLASH DRIVE

P0019XX00



Wooden flash drive to transport and store your personal files.

- small ring to connect it to your key holder or accessory cord.

Capacity: 8 GB

Material: Eco Friendly wood



Czech Police Special Forces training, Czech Republic •  Artsiom Hasiankou

WRISTBAND

P0024XX00



100% latex-free silicone wristband with debossed Singing Rock. Made from premium high quality rubber.

TEXTILE BADGE

10x4 cm – P0031XX01
15x6 cm – P0031XX02



Singing Rock textile embroidered badge to be stitched to your clothing, backpack or bag.
Size: 10 x 4 cm, 15 x 6 cm

PAPER BAG

P0033XX00
small – P0033XX02



Eco-friendly paper bag rounded paper handle supports a respectful approach to the environment.
Dimensions: 35x44x18 cm 24x33x12 cm

BANNER BAG

P0054XX00



There are many ways to save the environment. Like not leaving leftovers and not throwing away old stuff. That's the spirit behind this upcycle bag. It's made from old Singing Rock banners and has handles made from leftover ropes. When you get one, you give things that someone else would throw away a second life.

- bag made from old trade fair banners
- each piece is an original
- handles made from leftover ropes can be adjusted with any knot, factory made approx. 65 cm long

- hand wash the bag, rarely in the washing machine on gentle/sport programme (30 - 40°C), do not use fabric softener or dryer, the bag may not get a third chance
- made in the Czech Republic

Colour: various

Weight: 300 g

Material: used advertising banners, leftover ropes

Dimensions: 38 x 43 x 10 cm

Volume: approx. 16 l

NOTEPAD A5

P0030XX00



Manage your important tasks or jot down your to-do list with our Singing Rock notepads.

CONDOM

P0023XX00

**Safety first**

Your Personal Protective Equipment for your hardware.

Size: UNI

EN ISO 4074, CE 1023

SINGING ROCK PEN

P0022XX00



Ballpoint pen for everyday writing.

BANNERS

P0020



Singing Rock banners made from lightweight PES with a holes to hang up.

Size:
 P0020BB02
Small: 60 x 60 cm
 P0020BB03
Medium: 30 x 150 cm
 P0020BB04
Large: 200 x 100 cm
 P0020BB05
XLarge: 150 x 150 cm

BEACH FLAG

P0021



Self standing event flag. Made from elastic PES. Comes with a footstand and carrier bag.

Size:
 P0021BB00
Table: 29 x 60 cm
 P0021BB03
Medium: 60 x 260 cm
 P0021BB04
Large: 80 x 340 cm
 P0021BB05
XLarge: 85 x 450 cm

SINGING ROCK STICKERS

P0025XX00

with back and front side adhesive.

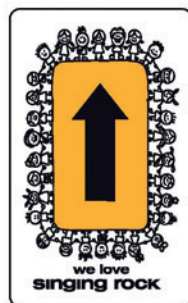
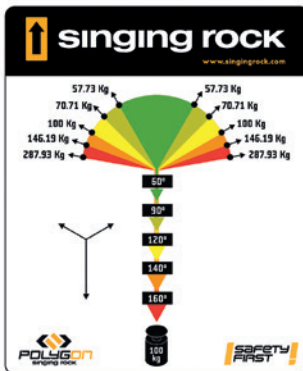
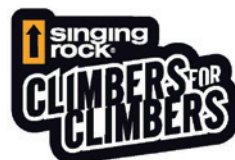

TECH INFO EN

P0028WE00

POSTERS

P0027WX00

690x990 mm



- Image posters with our gear in action.**
- 1. Silo 480x690 mm
 - 2. Helicopter Sweden 480x690 mm
 - 3. Tree Care 480x690 mm
 - 4. Tower Norway 690x480 mm
 - 5. Chairlift evacuation 690x480 mm



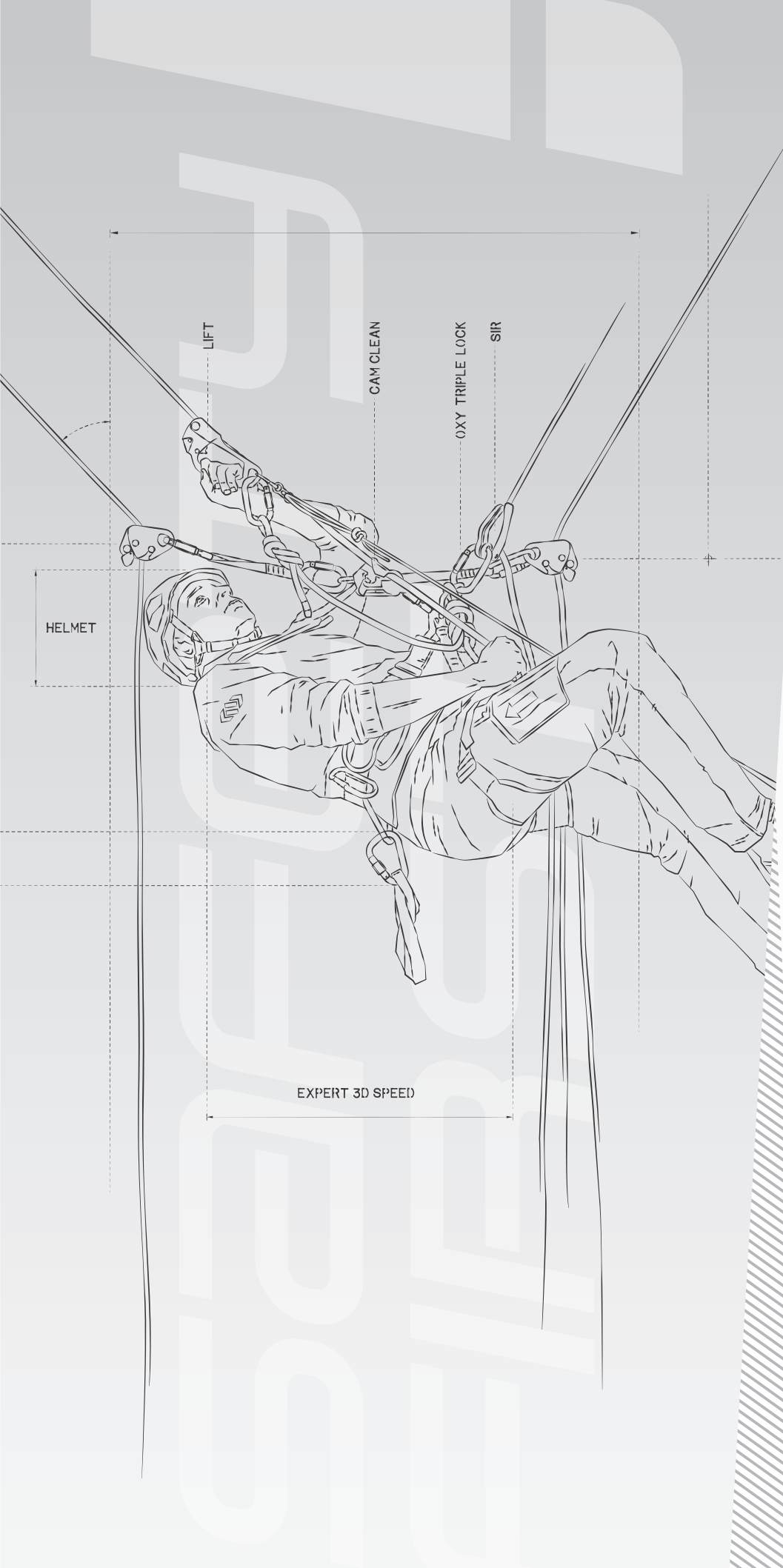

SERVICE & ACTIVITIES

**POLYGON TRAINING CENTRES
SCAFFOLDS AND INDUSTRIAL
HALLS**

FRAMING AND ROOFING

FALL ARREST

ROPE ACCESS

LADDERS

TREE CARE

**ROPE COURSES AND ADVENTURE
PARKS**

WIND TURBINES

CABLEWAY EVACUATION

**MILITARY AND SPECIAL
FORCES**



POLYGON



Over more than two decades on international markets, SINGING ROCK has become the world's leading manufacturer of Personal Protective Equipment (the "PPE"). In an effort

to provide its customers with comprehensive services and solutions in the area of security of workers at height and above depth, SINGING ROCK was the first in the Czech Republic and former eastern Europe to build a completely unique multifunctional training center POLYGON.

POLYGON facilities create the ideal conditions for providing occupational health and safety (the "OHS") training for work at height and above depth, for testing PPE, for organizing industrial climbing contests and many other

events associated with presentation and use of products and techniques related to this area. A number of specific simulations allow visitors to test safely proper techniques of safeguarding when working at height. All this under the direct supervision of experienced trainers while using complete equipment for these activities. With individual approach, high quality equipment and great emphasis on the practical part, our trainings in POLYGON became sought after among individuals and companies not only in the Czech Republic.

SINGING ROCK is certified as IRATA training company.

SINGING ROCK is the first and so far the only company in the Czech Republic to become a member of the globally recognized association IRATA.

IRATA – Industrial Rope Access Trade Association – was founded in the UK in order to ensure a safe working environment for workers at height. In a quarter of century of its existence, IRATA has become a leading expert in the field of security in work at height,

and in this field it is the only global association with many member organizations around the world.

Our operated IRATA courses therefore provide, in conjunction with our certificated POLYGON training centers, a unique opportunity to obtain the best possible qualification for work at height and above depth. After successful completion of the training the participant receives an IRATA certificate, which is valid



around the world and which is required by some foreign entities as the only possible prerequisite to carry out work at height.

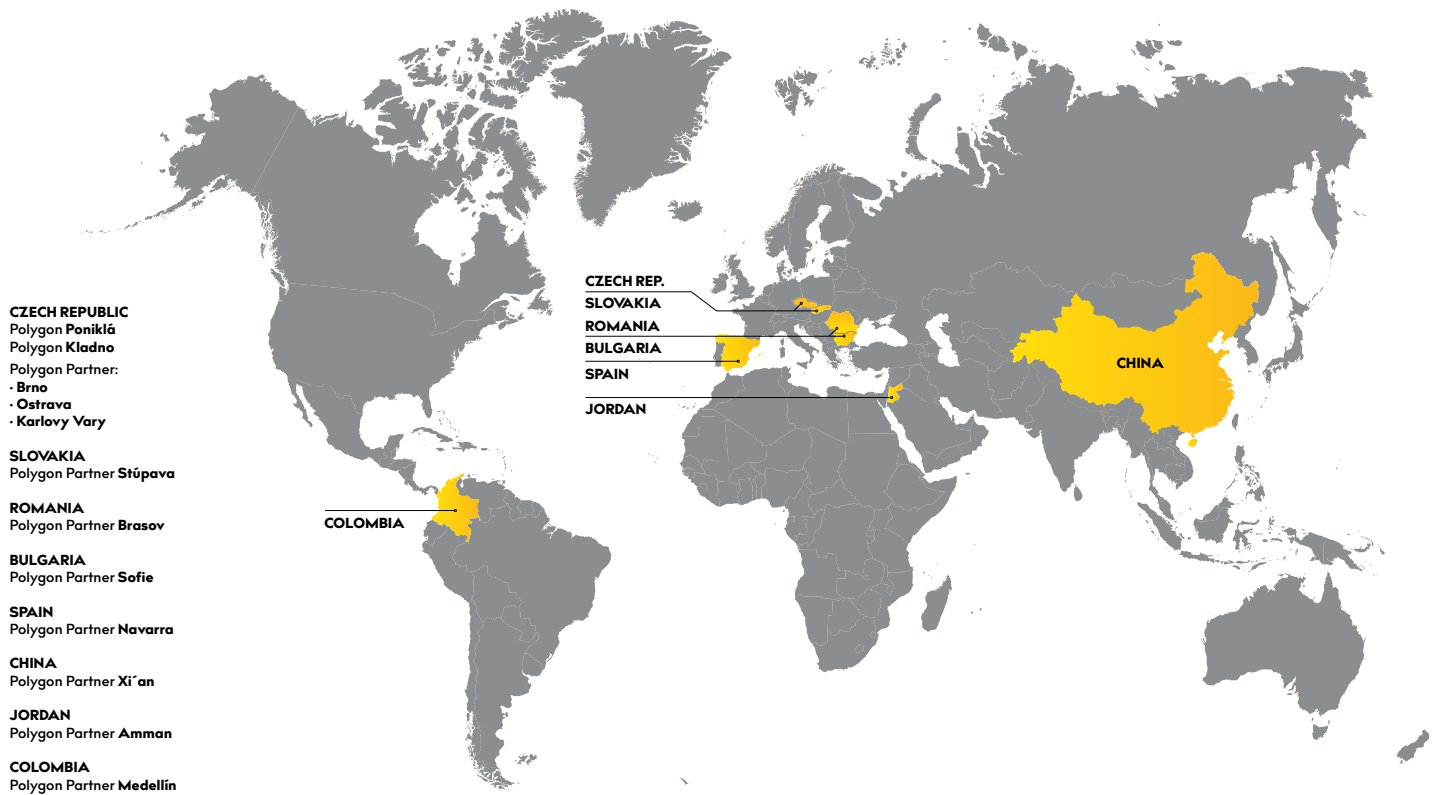

LIST OF SINGING ROCK POLYGON TRAINING CENTERS



POLYGON Poniklá Czech republic

Our first POLYGON is part of the SINGING ROCK headquarter and manufacturing factory in a picturesque valley of the Jizera river. It offers a number of model situations for work at height.

www.polygon-singingrock.com



POLYGON Kladno Czech republic

located in the former premises of Poldi Kladno – Konev. The former manufacturing building offers a real industrial environment to practice work situation when working at heights.

www.polygon-singingrock.com



Polygon Partner Brno Czech republic

Located in an industrial area in a former cement plant. Thanks to its height of more than 23m, it gives the opportunity to create a variety of model situations for work at height and rescue training.

www.klajda.cz/skoleni-prace-ve-vyskach-bozp



Polygon Partner Ostrava Czech Republic

Training centre situated in the unique historical industrial site where for more than 150 years thousands of miners used to mine a black coal.

www.polygonhlubina.cz



Polygon Partner Karlový Vary Czech republic

Until recently, the Karlový Vary region, situated in the west of the Czech Republic, didn't have a professional training centre for work at height. It was changed in May 2019. Now, this new POLYGON partner offers high-quality services to all applicants from that part of our country.



Polygon Partner Stúpava Slovakia

The Slovak Polygon partner offers a very diverse range of health and safety training for work at heights. Especially for tree climbers, persons professionally qualified to perform periodic inspections for PPE and more.

www.polygony.sk



Polygon Partner Navarra, Spain

Total HSE training centre is equipped with structures that simulate wind turbines, in order to offer true-to-life experiences in their courses. Except basic range of general work at height trainings can also provide GWO and IRATA courses.

www.totalhse.com



Polygon Partner Amman, Jordan

Beit Jala Training Center is located in Amman, capital city of Jordan. Except basic range of general work at height trainings can also provide individual trainings in clients location.

www.beitjala.com.jo



Polygon Partner Medellín, Columbia

The first POLYGON partner in the American continent provides courses and training, which are specifically regulated for the entire Colombian territory and are part of the mandatory compliance with the Occupational Health and Safety Management System, as well as some at international level. Intervenes in the control and management of hazardous work activities.

www.deporteka.com.co



Polygon Partner Sofia Bulgaria

Training centre situated in Sofia is operated by PROFIXT Ltd, IRATA # 6026/T which has been providing work at heights trainings and IRATA trainings for over 10 years in Bulgaria and has certified more than 400 industrial rope access technicians by the standards of the international system of IRATA.

www.profixt.com



Polygon Partner Xi'an China

Training center is located in Xi'an, Shaanxi province capital city with long history. Provide trainings mainly for fire-fighters and rescuers.



Polygon Partner Brasov Romania

This training centre is the first provider of training courses in work-at-height in the south-east of Europe. The centre is evolved through the volume of it's services, the number of technicians and most importantly through it's techniques in providing rope access services.

www.e-solo.ro



BASIC SKILLS

Work at height

Workers at height are in permanent danger of falling from a height. That is why their safety should always come first. Worker's safety is achieved by using various methods for setting up a personal fall protection system. The structure of the fall protection system should always correspond with the type of activity considering high efficiency of work along with maximal possible safety.

FALL FACTOR

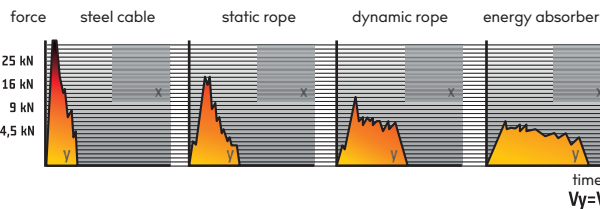

The impact force (IF) determines the maximum value of force generated during fall arrest of the object by the safety chain. The value of IP has a direct impact on the safety of worker at height. Ideally, we avoid IP if we reduce it to the lowest level possible (max 6kN)

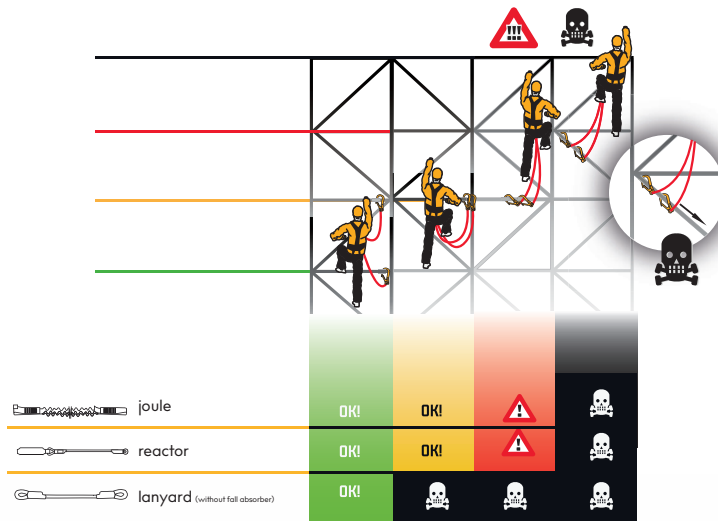

When safeguarding an ascent using a fall arrest type „Y“ it is necessary to move at the level FFI and lower. It means that the connectors (EN362) connected to the fall absorber (EN355) during the ascent do not „fall“ below the connection point of the harness (EN361) in which the absorber is connected to the harness.

ANCHORING

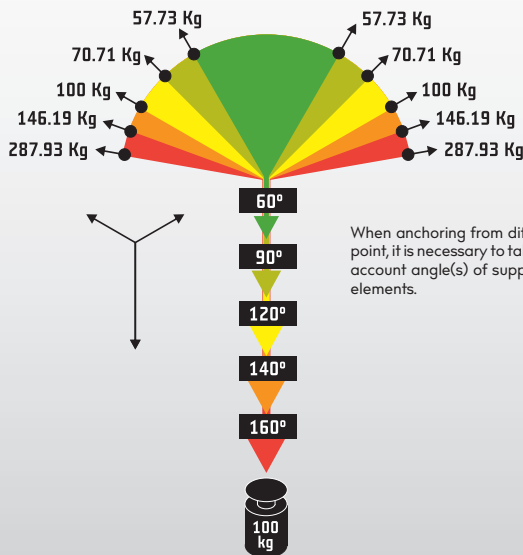
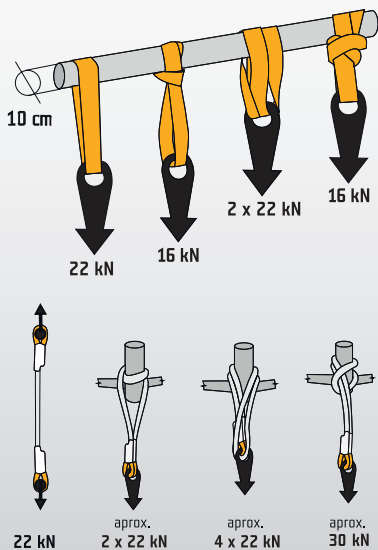

When anchoring from different point, it is necessary to take into account angle(s) of supporting elements.

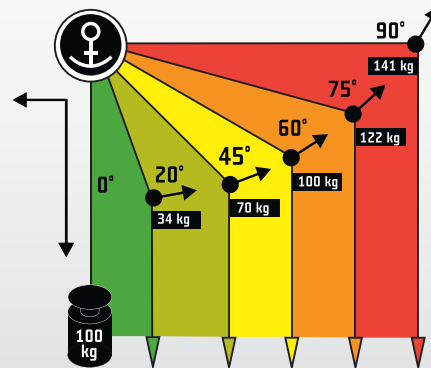

Load of continuous anchoring point. An example is creating a deviation using rope techniques.

KNOTS



Figure-Eight knot

Connection of two ropes using an eight knot

- Reduces the strength of rope in lab. conditions by approx. 46%
- used to connect two ropes of the same type and same diameter, connection of ends of a rope loop

Connection of ends of one rope loop

Connection of two ropes using an eight knot

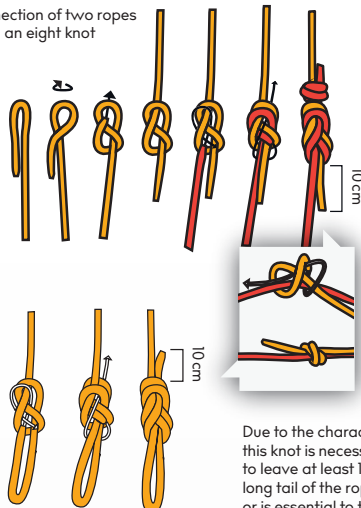

Due to the character of this knot is necessary to leave at least 10 cm long tail of the rope or is essential to tie a backup knot, double fisherman's knot

CONNECTING KNOTS

Double fisherman knot

Connection of two ropes using a double fisherman knot

- Reduces the strength of rope in lab. conditions by approx. 32%
- connection of two ropes (rope loops) of different type or diameter

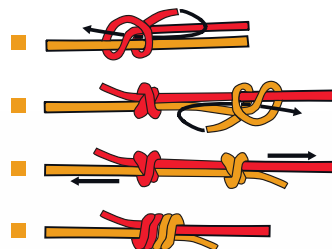

Overhand follow through
Used to join two ropes or slings together. When loaded it is harder to untie it.

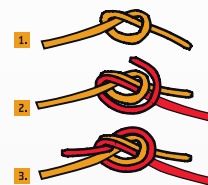

FRICION KNOTS

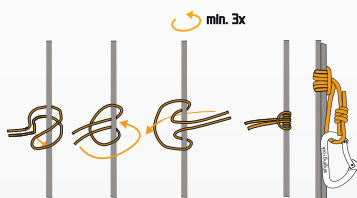

Prusik knot

Simple and the easiest friction knot. It works in both directions. Normally made from accessory cords 5-6 mm diameter. It is possible to make it with one hand only. Note: the joining knot must be kept away from the rope to prevent slippage.



Klemheist (Machard) knot

Works very well, suitable also for flat slings, it's possible to make it also from thicker diameter slings (up to 9mm).

ANCHORING KNOTS

Clove hitch

Reduces the strength of rope in lab conditions by approx. 12%
Use: anchoring
It is possible to make it with one hand only, it is easy to untie after the loading

Double figure eight loop (Bunny Ears)

Very useful for equalizing the load on two anchor points.

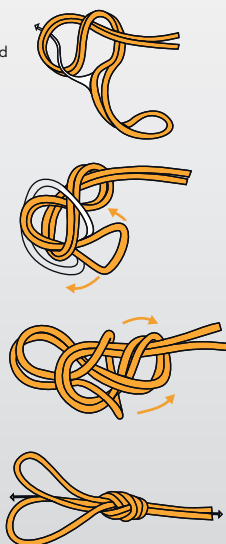

Lanyard with a whipped loop
Using lanyard with a loop is the best possible method of eliminating the possibility of erroneous tying of a knot during anchoring.

BELAY KNOT



Munter hitch

Knot used for belaying with HMS carabiner. There is no static friction on any part of the rope as it is a continuously moving knot. It is easy to tie even with one hand or with the gloves on the hands. The part of the rope going to belayer must not go through the gate of the carabiner.

Alpine butterfly

Reduces the strength of rope in lab. conditions by approx. 39%
Use: anchoring; anchoring from separate points, inter-anchoring.

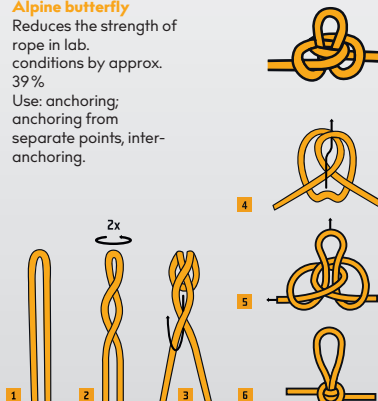

Due to the character of this knot is essential to tie a backup knot, double fisherman's knot.



SCAFFOLDS AND INDUSTRIAL HALLS

Many people are injured each year when they fall from scaffolds. Scaffolds should be erected by trained and competent people. There are a number of organisations that provide training for the safe use of scaffolds. A scaffold is one way to prevent a fall when working at height. The type of scaffold selected must be suitable for the work and erected and dismantled by people who have been trained and are competent to do so. Those using tower scaffolds should also be trained in the potential dangers and precautions required during use. Tower scaffold provision and use must be properly managed and include rigorous scaffold inspection arrangements.



Delimitation of working area by restricting access to dangerous areas.

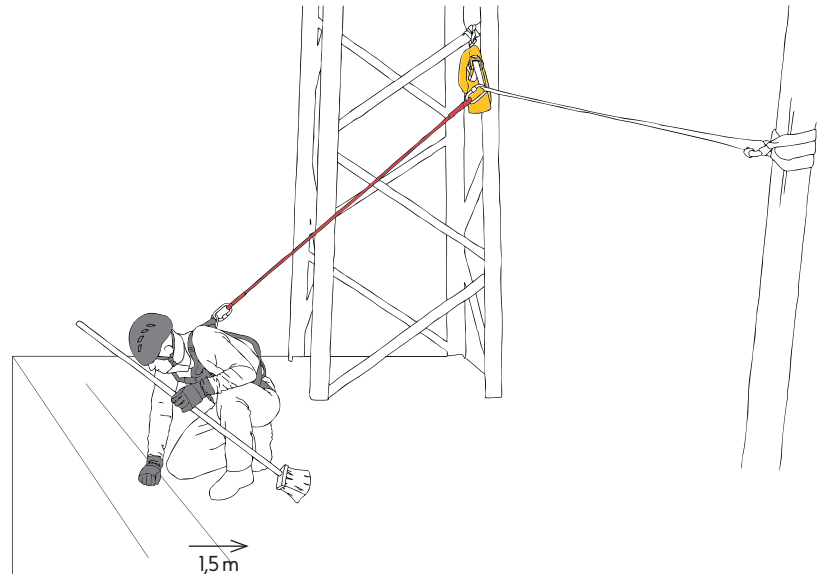

Use of mobile safety system (Fine line) to delimit safe working area

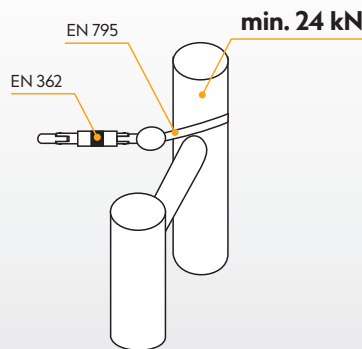
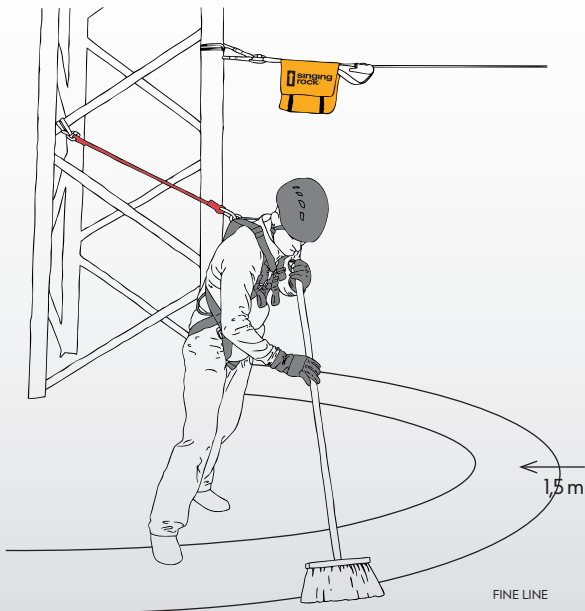

setup

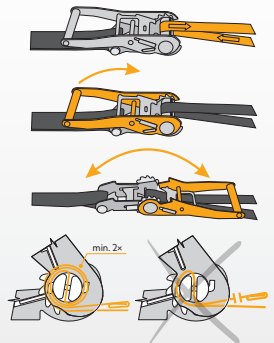

dismantling

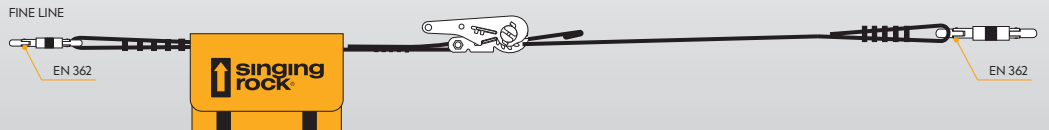



W0068BR
BODY II speed
fall arrest harness

RECOMMENDED GEAR

RK850X100
STEEL LANYARD „I”
130 cm



ADJUST
W1047Y100
adjustable lanyard



W4100Y120
JOULE 120
the fall absorber
120 cm



W2001
OPEN SLING
sewn sling, 120cm



W101WB02
SITE
work positioning lanyard



A4000S
IKAR HWS
Retractable fall arrest system



X0075XX14
BANTAM BEAMER



W9601
FLASH INDUSTRY
working helmet



K424IZ005
OVAL STEEL CONNECTOR
screw



K0122EE05
OXY screw
light alloy oval carabiner



K82310Z
MAILLON BOG D
steel maillon carabiner



W1010BB09
LOCKER
guided type fall arrester



L0041 – L0081
ACCESSORY CORD
6mm, 20m



S9000BB50
GEAR BAG
waterproof bag



SCAFFOLDER SET



M0021XX

Scaffolder set is intended for those, who install scaffolds or work on tall structures and towers. It allows you to reach safely a place of work and position there for work.



ROOFING

When moving on the roofs, there is always the risk of fall through or slip followed by a fall. To eliminate this risk it is necessary to set up sufficiently strong anchor point and to use proper PPE. If there is no sufficiently strong anchor point, it is necessary to use more anchor points together. The anchorage must be placed above the worker to prevent him/her from a fall. If there is a risk of falling, it is necessary to incorporate a fall absorber into the safety chain. Pay attention to the horizontal distance from the vertical of the anchor point. The bigger it is the more dangerous possible fall will be.

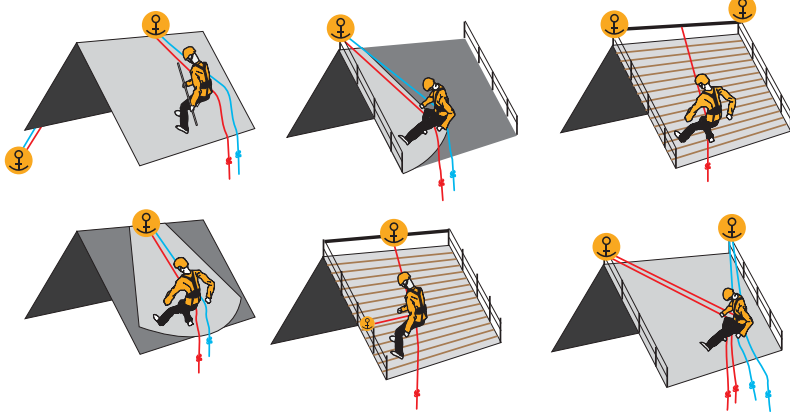
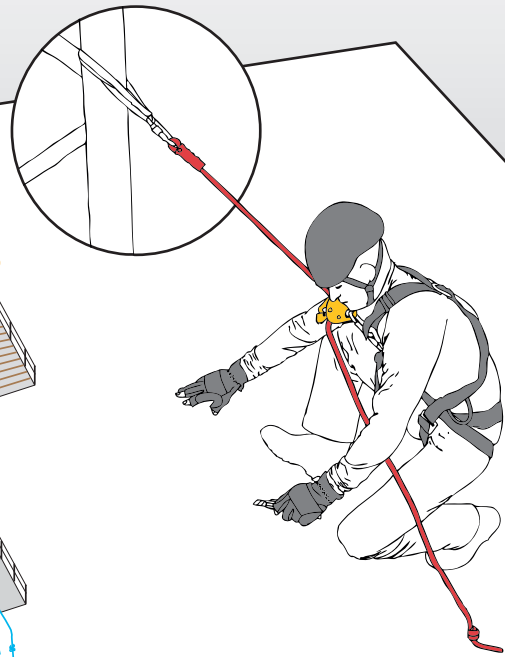
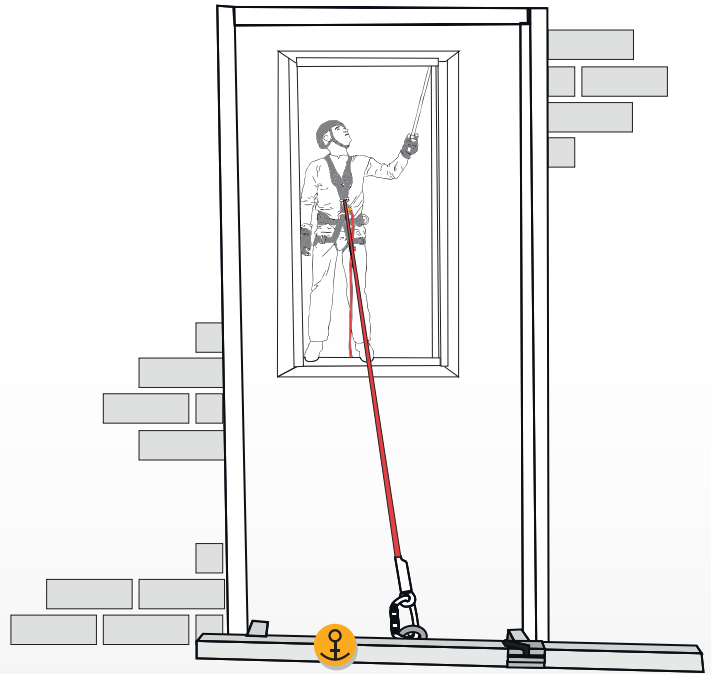
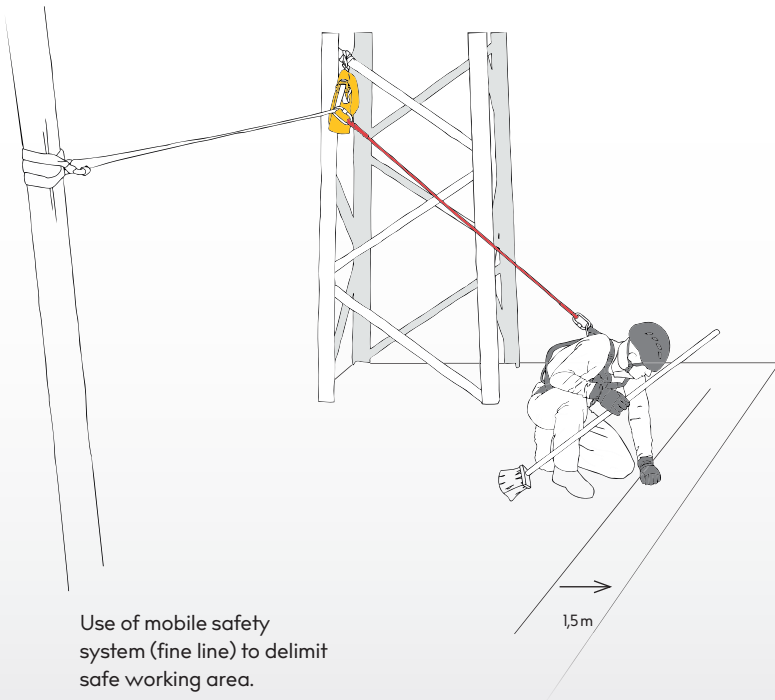

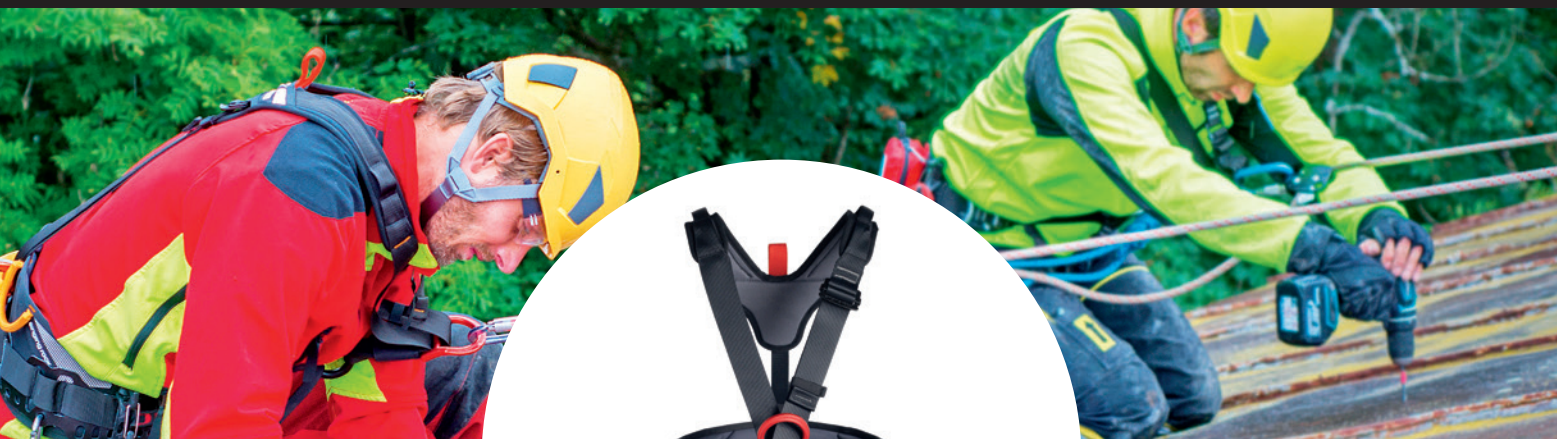

W0091BY
ROOF MASTER
Lightweight and fully adjustable full body harness

RECOMMENDED GEAR

W9603RX
FLASH ACCESS
working helmet



K424IZ005
OVAL STEEL CONNECTOR
srew



K0122EE07
OXY triplelock
light alloy oval carabiner



K424IZ007
OVAL STEEL CONNECTOR
triplelock



W1010BB09
LOCKER
guided type fall arrester



C0012YB
FALCONER FULL



W2016*080
SLING LANYARD
sewn sling



W9004YX00
TOOLKIT
special carry bag



W1001WS10
FINE LINE BAG
mobile anchoring system bag



W1001WW10
FINE LINE
mobile anchoring system



L0250RR
Static 11.0
static rope



W8100B
ROPE PROTECTOR



ROOFER SET



M0020X1 – Roofer set 10 m,
M0020X2 – Roofer set 20 m
Roofer set 10 is ideal for those, who are fully devoted to roofing. It allows you to position yourself on a roof with up to 45° angle to prevent a possible fall due to slippage or breaking of a structure.



TOWERS AND RIGGING

- Working on tall structures may involve fall arrest, work positioning, rope access and possibly evacuation.
- If no stable safety system is present and the structure needs to be climbed repeatedly a flexible fall arrest line may be required
- For climbing on the frame construction of metal towers fall absorber may be essential.
- Construction demands a full range of fall protection solutions to meet the needs of a dynamic workplace. That's why workers turn to SINGING ROCK for expertise, superior quality products and continual systems innovation.

Some basic principles of using ropes and lanyards:

Keep your rope out of any sharp edges, rough surfaces and chemicals. Especially on slopes anticipate potential direction of fall and the strain of your rope. When working on constructions, pay attention to the direction of leading your rope and anticipate its possible strain. When using lanyards either to climb the construction or to positioning, take heed to reduce potential fall to minimum! Therefore always place the anchor point above the worker.

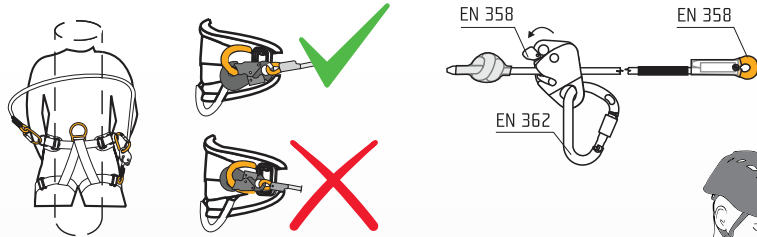
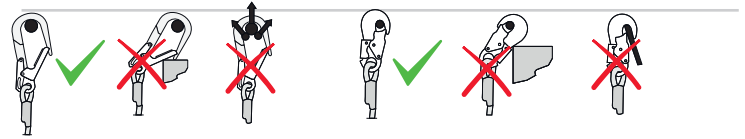
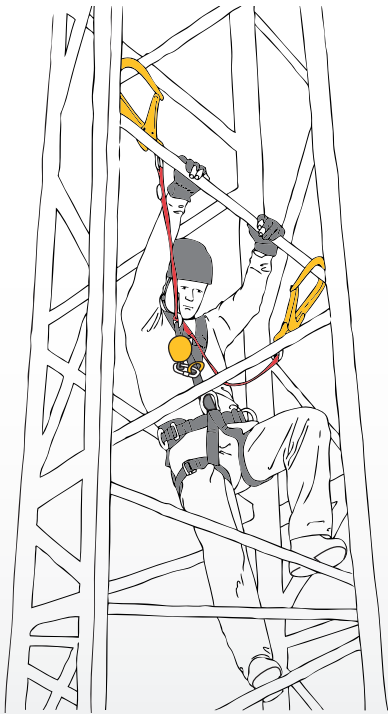
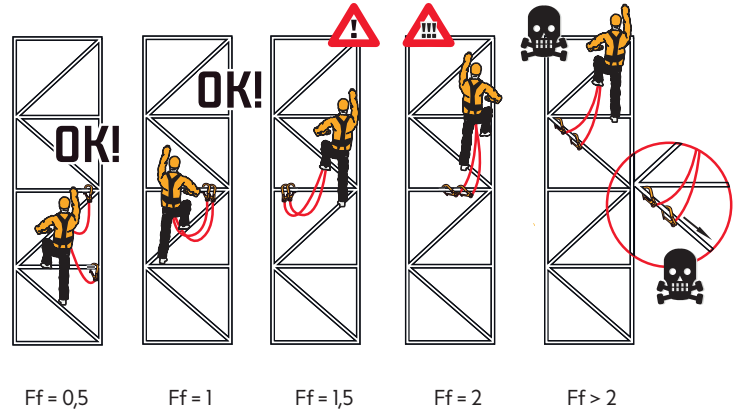

Fall absorbers:

When using a fall absorber, the elongation of the fall absorber during breaking action shall be considered. As there are different types of fall absorbers on the market, safe use of this product requires careful reading and understanding of instructions for use, where the method of calculation maximal possible elongation of fall absorber is stated. For your safety we recommend to add another 0.5m to the calculated distance.

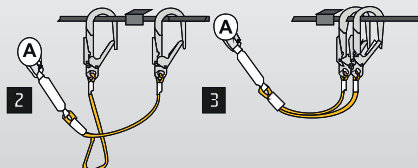
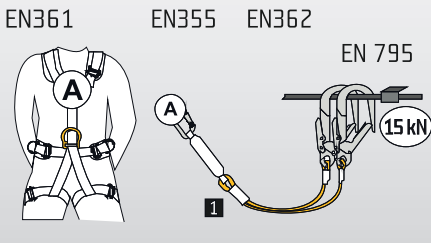

Work positioning on a frame construction

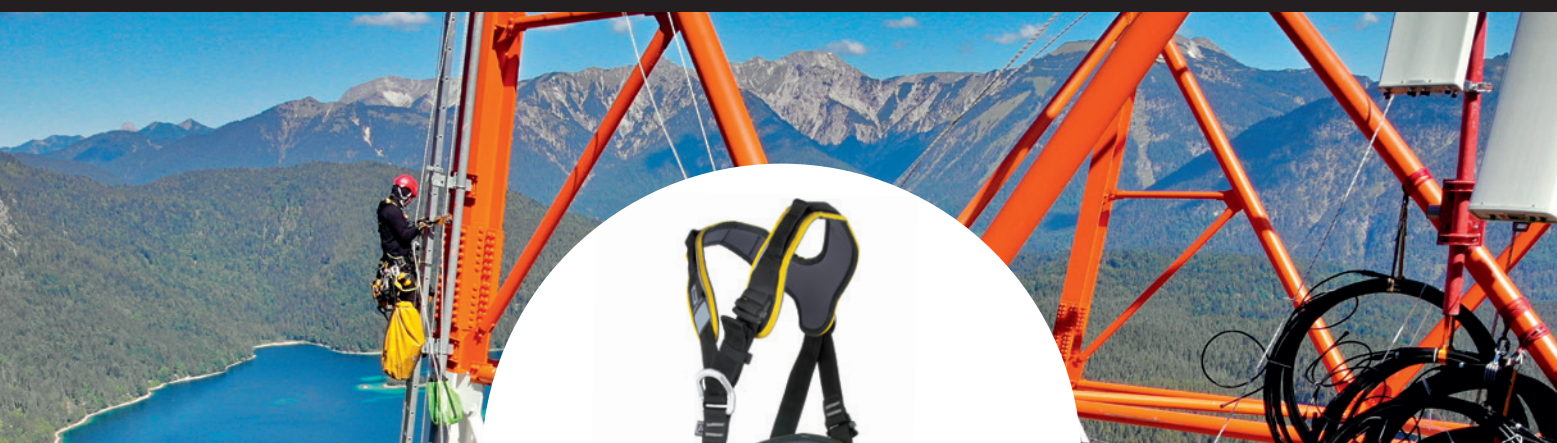

W0081DR
PROFI WORKER 3D
 standard
 fully adjustable
 fall arrest and
 rope access harness

RECOMMENDED GEAR

W9607
BLAST
 working helmet



C006BH
GRIPPY
 leather gloves



W1010BB09
LOCKER
 guided type fall
 arrester



K0122EE07
OXY triplelock
 light alloy oval
 carabiner



K4241Z005
**OVAL STEEL
 CONNECTOR**
 triple lock



W0052B010
WORKING BAG
 transport bag for
 working harness



W1012WB
SITE + K370
 work positioning
 lanyard



W4400WW00
REACTOR 140
 shock absorber



W2016080
SLING LANYARD
 sewn sling



W2001
OPEN SLING
 sewn sling



K9000BB03
PORTER
 plastic holder



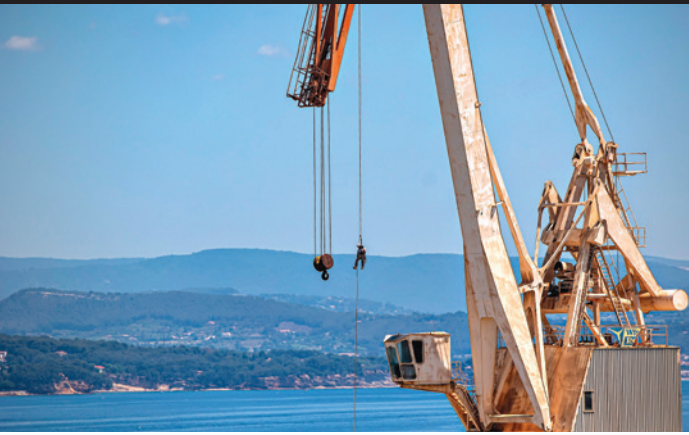

ROPE ACCESS

Rope access is called "royal discipline" in working at height activities. This working method is fast, effective, has little effect on the workplace and it is very quick to install and dismantle. It is used for a wide variety of work: cleaning, painting, inspection and other working situations.

Rope access or industrial climbing is a form of work, which applies practical ropework to allow workers to access difficult-to-reach locations without the use of scaffolding, cradles or an aerial work platform. Rope access technicians descend, ascend, and traverse ropes for access and work while suspended by their harness. Sometimes a work seat may be used. The support of the rope is intended to eliminate the likelihood of a fall altogether, but a back-up fall arrest system is used in case of the unlikely failure of the primary means of support. This redundancy system is usually achieved by using two ropes - a working line and a safety line.

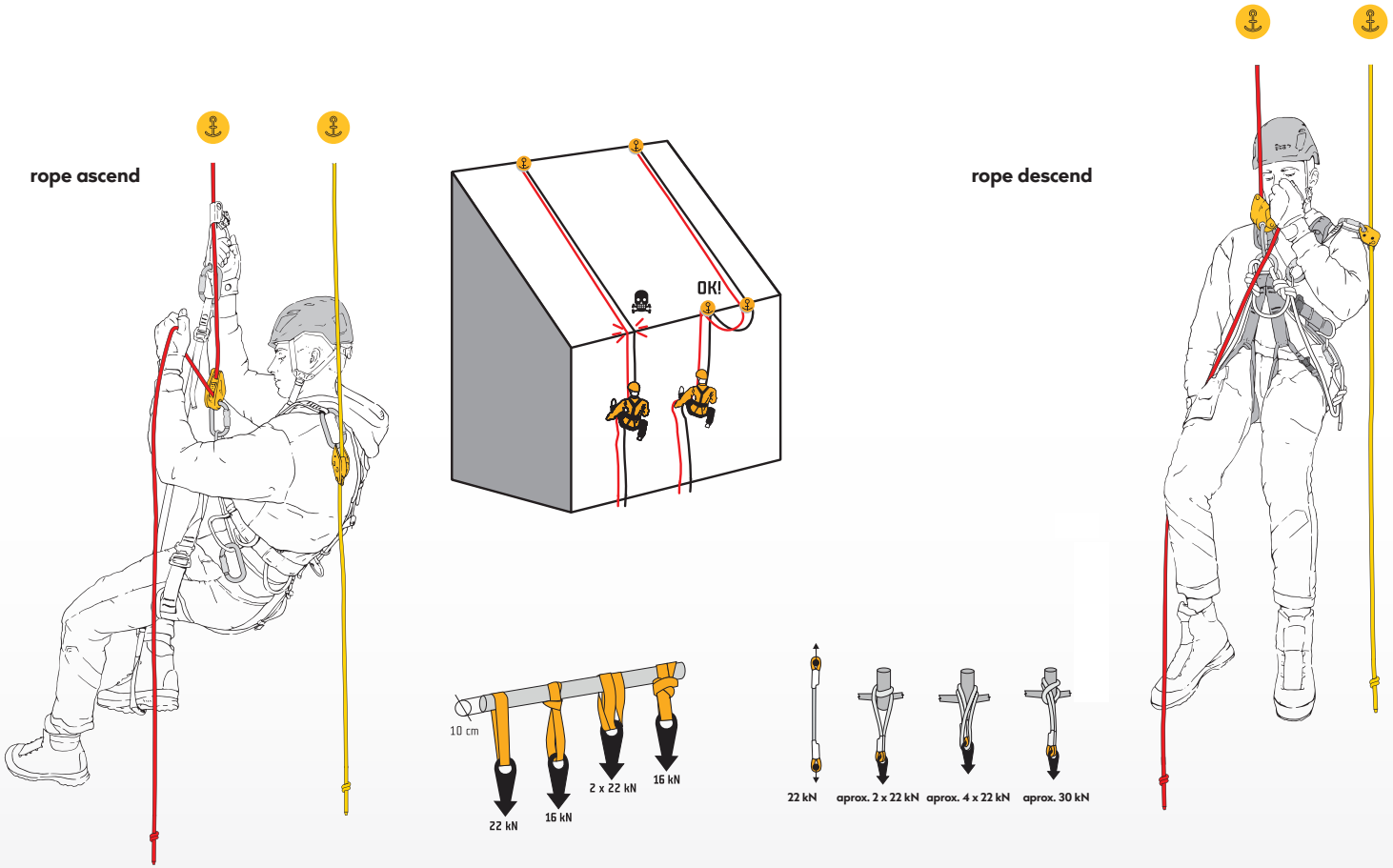

Working position with a descender.

Place hand and chest ascenders.

Position body into the descender and ascenders, re-place the fall arrester.

Take of the descender.

Place descender and take off a chest ascender.

Take off a hand ascender.

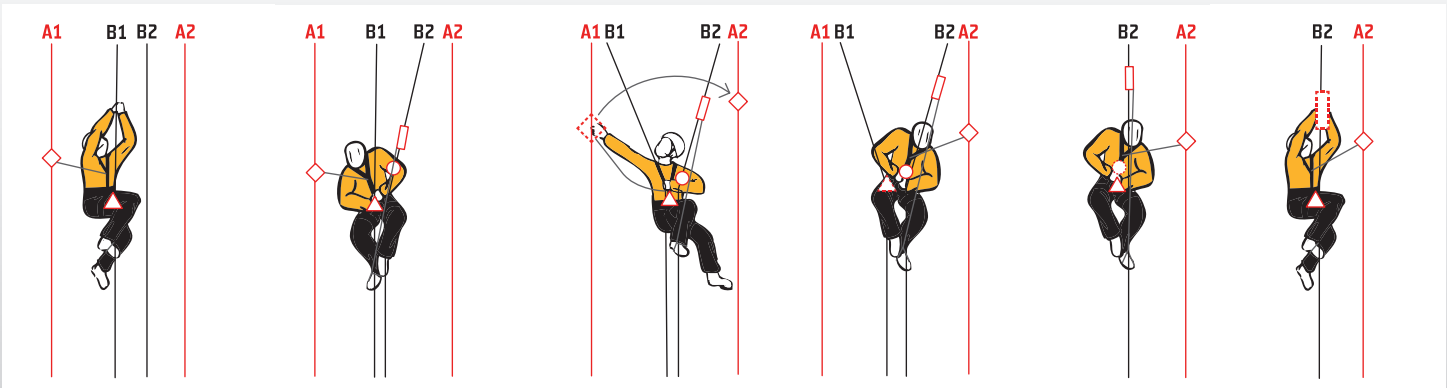

Short rope-to-rope transfer: off belay descender (SIR) hand ascender (LIFT) chest ascender (CAM CLEAN) positioning sling in a knot (COW'S TAIL) fall arrester (LOCKER)



W0079DR
EXPERT 3D
speed
 fully adjustable
 rope access
 harness

RECOMMENDED GEAR

W9607
BLAST
 working helmet



RK804BX0R
LIFT
 hand
 ascender



RK805BX00
CAM CLEAN
 Chest
 ascender



W1010BB09
LOCKER
 guided type fall
 arrester



K032SIR00
SIR
 multipurpose
 device for rope
 access



K0122EE07
OXY triplelock
 light alloy oval
 carabiner



K424IZ005
OVAL STEEL
CONNECTOR
 triple lock



RK801EE00
PULLEY EXTRA
 durable and
 lightweight pulley



W0010YB
FRANKLIN
 work positioning
 seat



W1015B020
LOCKER SLING
 certified sling for the
 Locker



W2001
OPEN SLING
 sewn sling



L0450WG
STATIC
R44 11.0
 static rope



L0450RR
STATIC R44 11.0
 static rope



W8100B
ROPE
PROTECTOR



K00500S03
EDGE ROLLER
 rope protector





PERMANENT LIFELINES

Permanent lifelines serve to secure workers in places where it is possible to set up fixed anchor point in the working place or near it. These are then interconnected by steel rope or a rail. For moving and securing, the worker uses connectors (EN 362) or special slider made for this purpose and supplied by the system manufacturer. The advantage of permanent lifelines is their long operating life and variability of use.

Fall arrest systems form an important element of the safety chain. When used correctly, they ensure sufficient absorption of fall energy, thus preventing the worker's body from being damaged. If the worker faints during or after fall, it is necessary to transport him to a safe place. The long hanging of unconscious body may have fatal consequences (trauma caused by hanging). Therefore keep in mind that fall arrest systems should be only used by trained workers. In case of need they should be able to aid each other at rescue and recovery action.

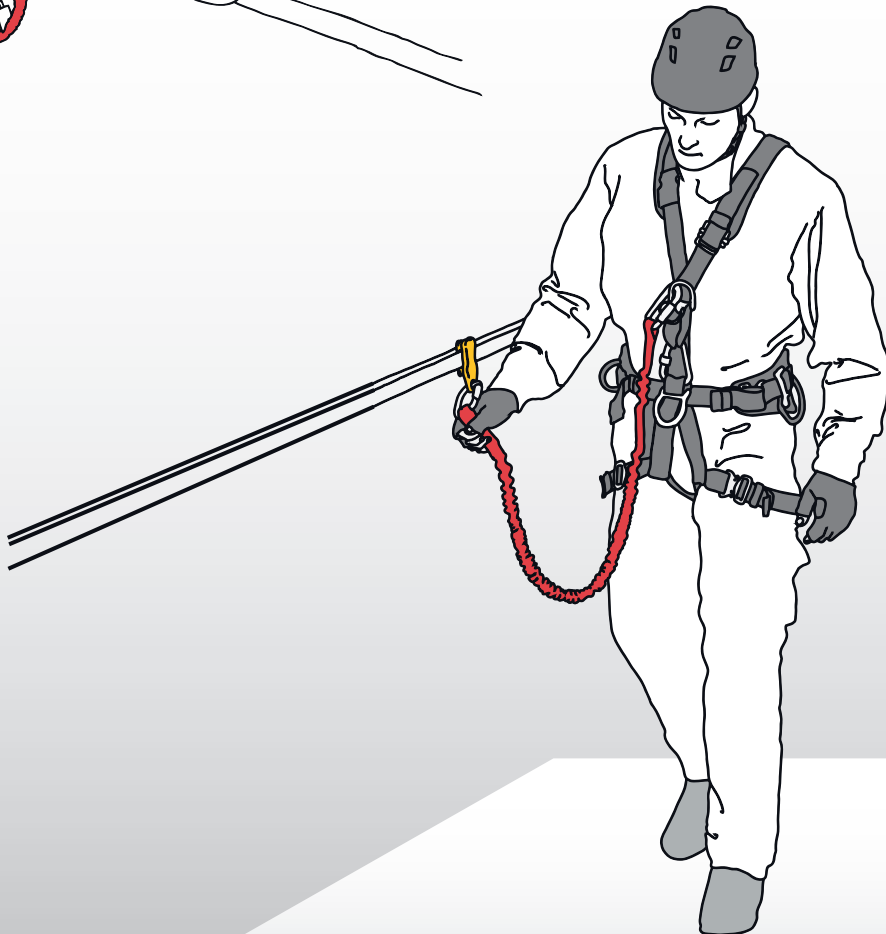
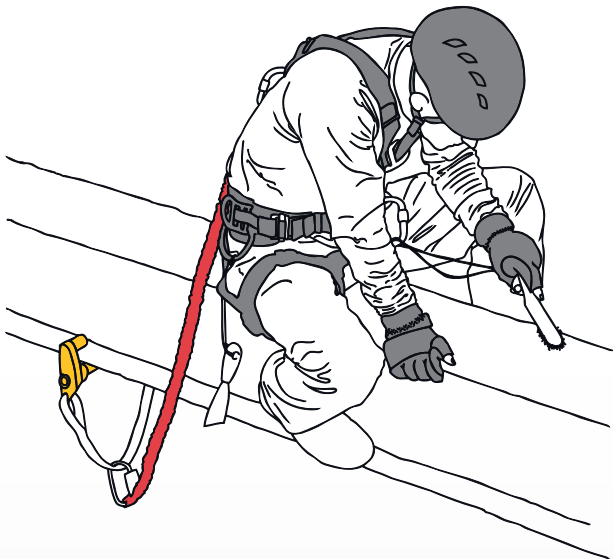



W0063BB
TECHNIC standard
 fully adjustable
 fall arrest
 and positioning
 harness

RECOMMENDED GEAR

W9600
**FLASH
 INDUSTRY**
 working helmet



W0052B010
WORKING BAG
 transport bag for
 working harness



W1010BB09
LOCKER
 guided type fall
 arrester



K0122EE07
OXY triplelock
 light alloy oval
 carabiner



K4241Z005
**OVAL STEEL
 CONNECTOR**
 triple lock



RK801EE00
PULLEY EXTRA
 durable and
 lightweight pulley



W1012WB
SITE + K370
 work positioning
 lanyard



W4462X085
**REACTOR 140
 ROPES „Y“ 85 cm**
 shock absorber



X0075XX14
**BANTAM
 BEAMER**



W4100Y120
JOULE
 energy
 absorber



W2016080
SLING LANYARD
 sewn sling





TREE CARE

An arborist is a professional in the practice of arboriculture, which is the cultivation, management, and study of individual trees, shrubs, vines, and other perennial woody plants in dendrology and horticulture. Arborists generally focus on the health and safety of individual plants and trees, rather than managing forests or harvesting wood.

Arborists who climb can use a variety of techniques to ascend into the tree. The least invasive, and most popular technique used is to ascend on rope.

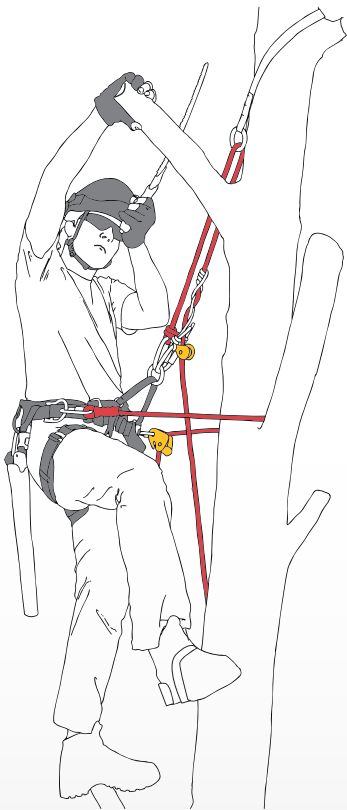

There are two common methods of climbing:
Single Rope System (SRS) and
Moving Rope System (MRS).

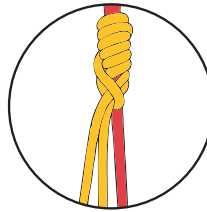

Prior to starting work, the arborist in the tree must always have two independent adjustable positioning devices.

One of the most effective options of getting into the tree is setting up ascent ropes from the ground. It is done by throwing a light bag carrying a thin rope over the required anchor point. The ascent system is then pulled by this light rope.



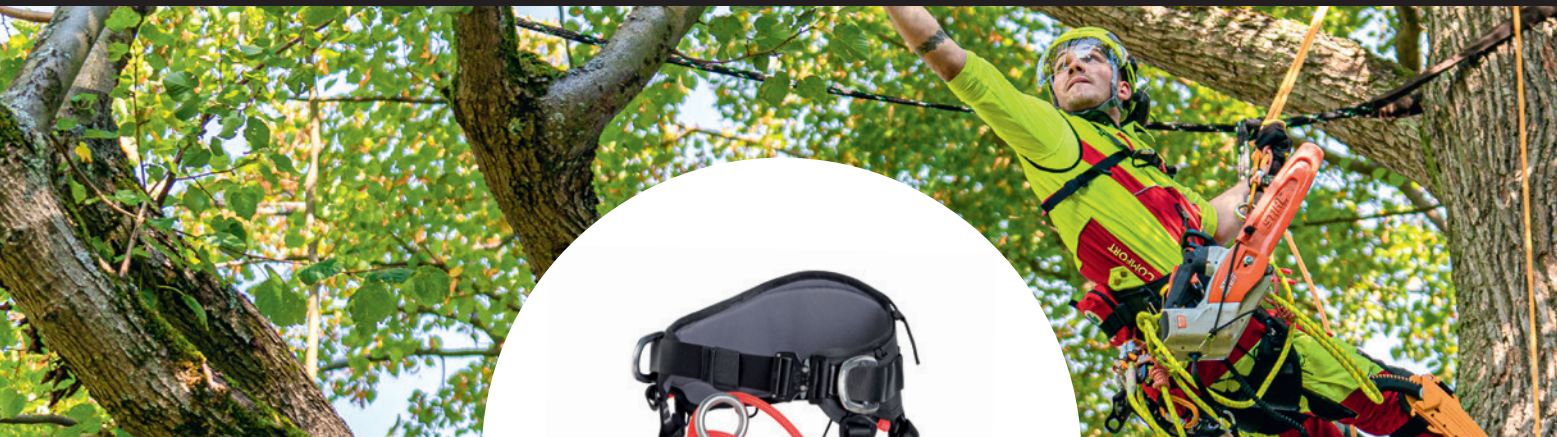

W0105BR
ARBO MASTER
tree care harness

RECOMMENDED GEAR

W9602
FLASH AERO
working helmet



RK804BX0R
LIFT
hand ascender



K0119EE00
BORA triplelock
light alloy HMS carabiner



K0122EE07
OXY triplelock
light alloy oval carabiner



L0460RV00
TILIA 11.5
static rope



K032SIR00
SIR
multipurpose device for rope access



L9031YX10
THROW LINE
arboristic throwline



W1028BY00
TOOL HOLDER



W9500Y
TREEMOUSE
arboristic throwing bag



C0053RW
FIRS AID BAG
(without contents)



RK800EE00
PULLEY SMALL
durable and light weight pulley



C0001YY00
CARRY BAG
practical bag for a rope



W2608
TIMBER ACCESSORY CORD
with sewn eyes

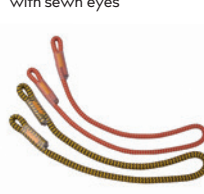

W2001
OPEN SLING
sewn sling



W1024BX
FOOTER II
ascender webbing



W2601R085
PRUSIK SLING
sewed accessory cord



W2603YB00
PULLEY SLING
prusik sling with a pulley



W2115
BARK PULLEY SAVER
cambium saver



W2117
ARBO SITE
work positioning



W2114
TREE ANCHOR
anchor device



W0108BR00
ARBO CHEST
padded chest harness



RK807BX0
FOOT LIFT
foot ascender





ROPES COURSES AND ADVENTURE PARKS

Rope parks are a combination of climbing and professional activities. It is a leisure-time activity mainly carried out by people who are gaining the experience with climbing. This activity combines working as well as sport equipment. The person (client) is ideally dressed in a full body harness, connected to the steel rope with two connectors and these are connected to the harness by a textile sling or lanyard. In addition, the client is equipped with a tandem pulley, which is connected to the harness by a sling or lanyard.

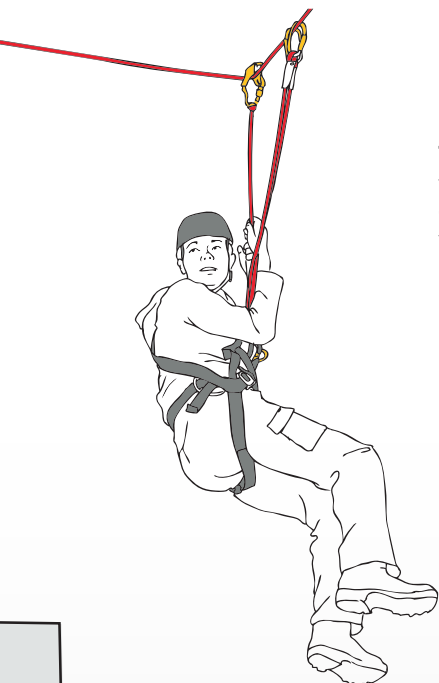

Zip Line At zip line the client first attaches a tandem pulley to the steel rope, behind the pulley, client attaches the first and second back up sling with the connector. The whole weight of a client is in the pulley. Back up slings move freely behind the pulley.

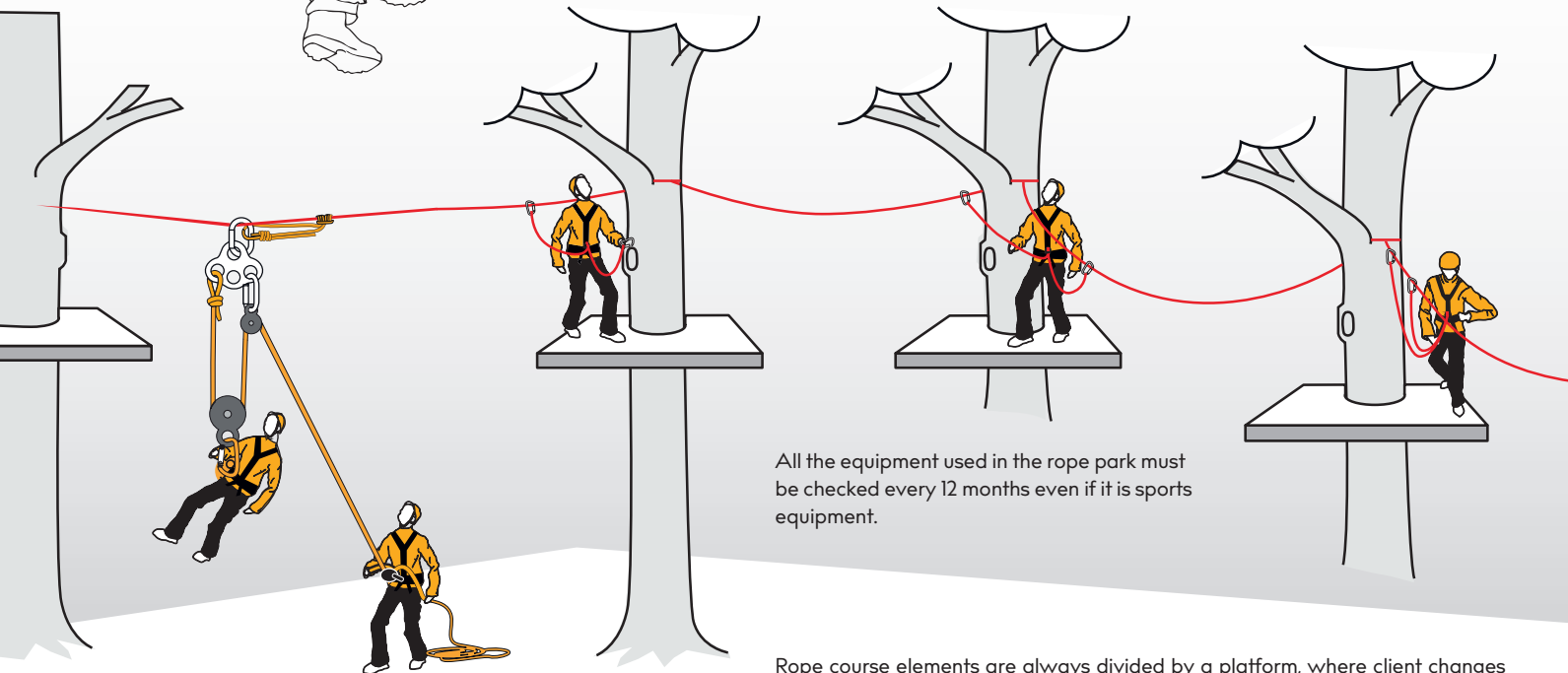
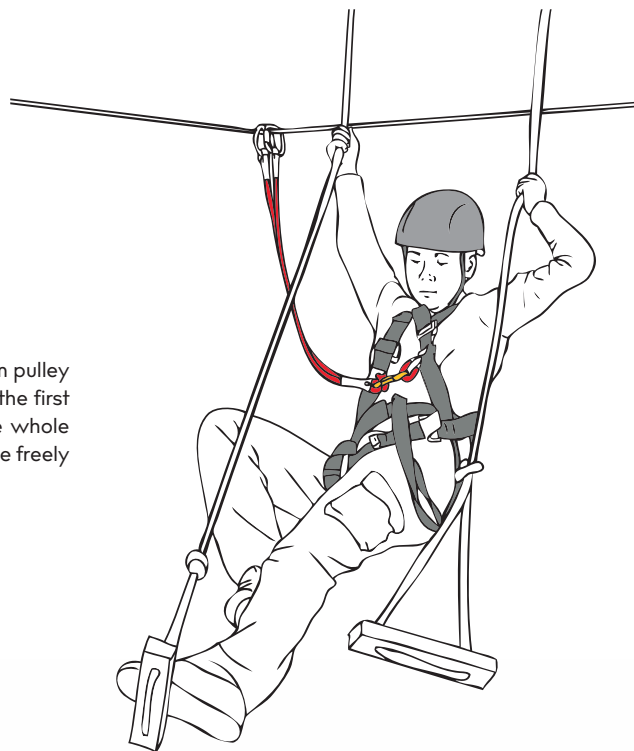

All the equipment used in the rope park must be checked every 12 months even if it is sports equipment.

Rope course elements are always divided by a platform, where client changes the connectors from a steel security rope to another one. The client always has to lock one security loop and the other security loop. It must never happen that both connectors are disconnected from the security steel rope at the same time. It is the same system as securing on via ferrata.

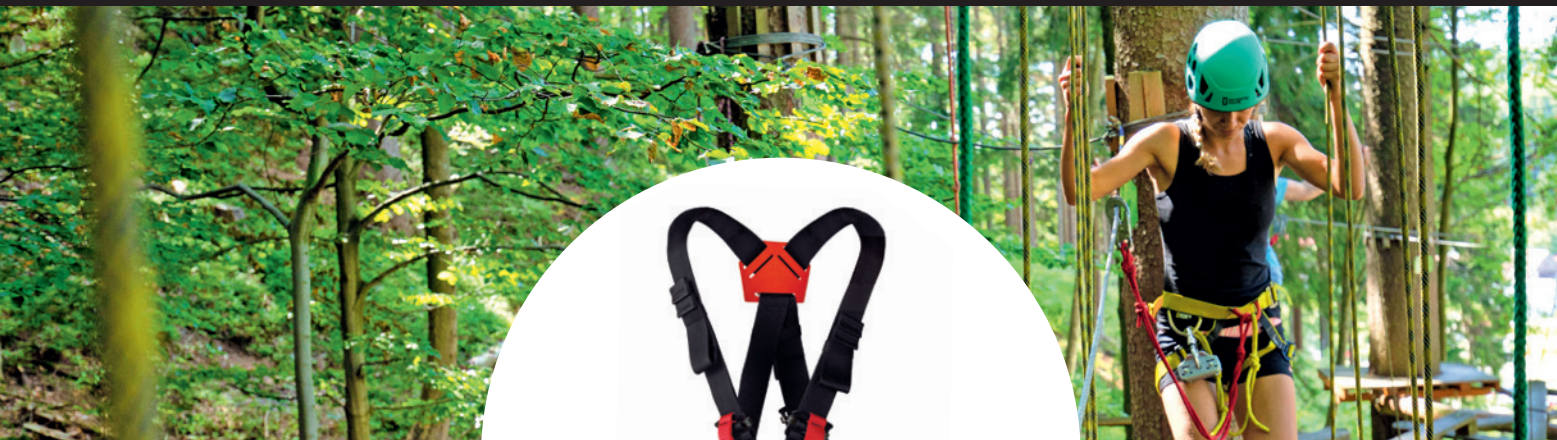

W0059BR
TARZAN ECONOMIC
full body harness

RECOMMENDED GEAR

C0900
HEX
climbing helmet



K82008Z
SMALL CONNECTOR
with automatic locking



K82008Z
MAILLON SMALL OVAL
steel maillon carabiner



K0122EE07
OXY triplelock
light alloy oval carabiner



K4241Z005
OVAL STEEL CONNECTOR
triple lock



RK803BB00
TANDEM PULLEY



K9000BB03
PORTER
plastic holder



C0053RW
FIRS AID BAG
(without contents)



C0012YB
FALCONER FULL



W2200W100
LANYARD „1”



S9000YY35
GEAR BAG
waterproof bag



EVACUATION SET

K032SIR00
SIR
multipurpose device



RK713BB00
RIGGING PLATE 1/3
anchoring device



K4241Z005
OVAL STEEL CONNECTOR
srew



K0122EE07
OXY triplelock
light alloy oval carabiner



RK800EE00
PULLEY SMALL
durable and light weight pulley



RK801EE00
PULLEY EXTRA
durable and lightweight pulley



W1052XX00
RESCUE RATCHET





WIND TURBINES

Work at height for wind turbine operators includes the elements of a safe system of work, equipment selection and inspection, use of tools, risk assessment, method statements and emergency procedures. Evacuation and rescue using industry standard equipment are practiced at height.

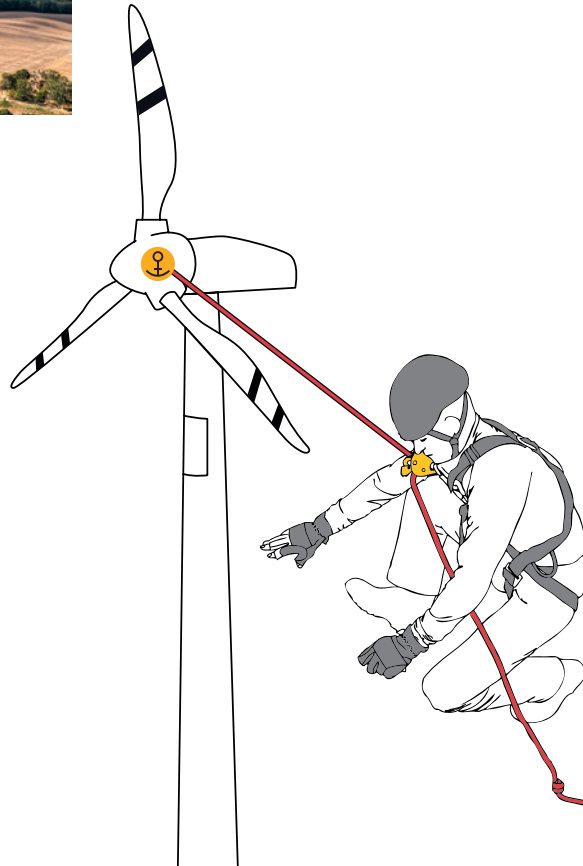
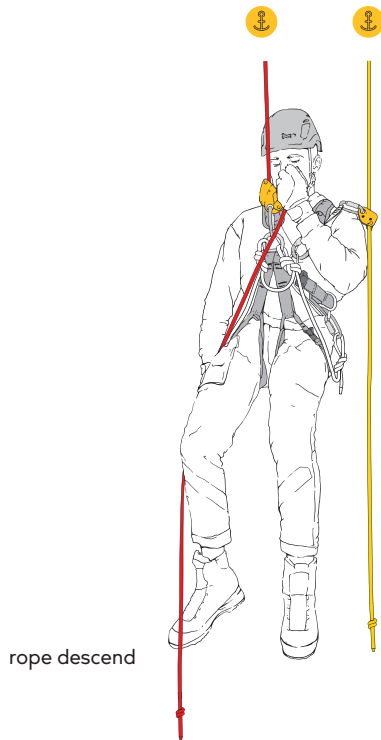

BASIC PULLEY SYSTEMS

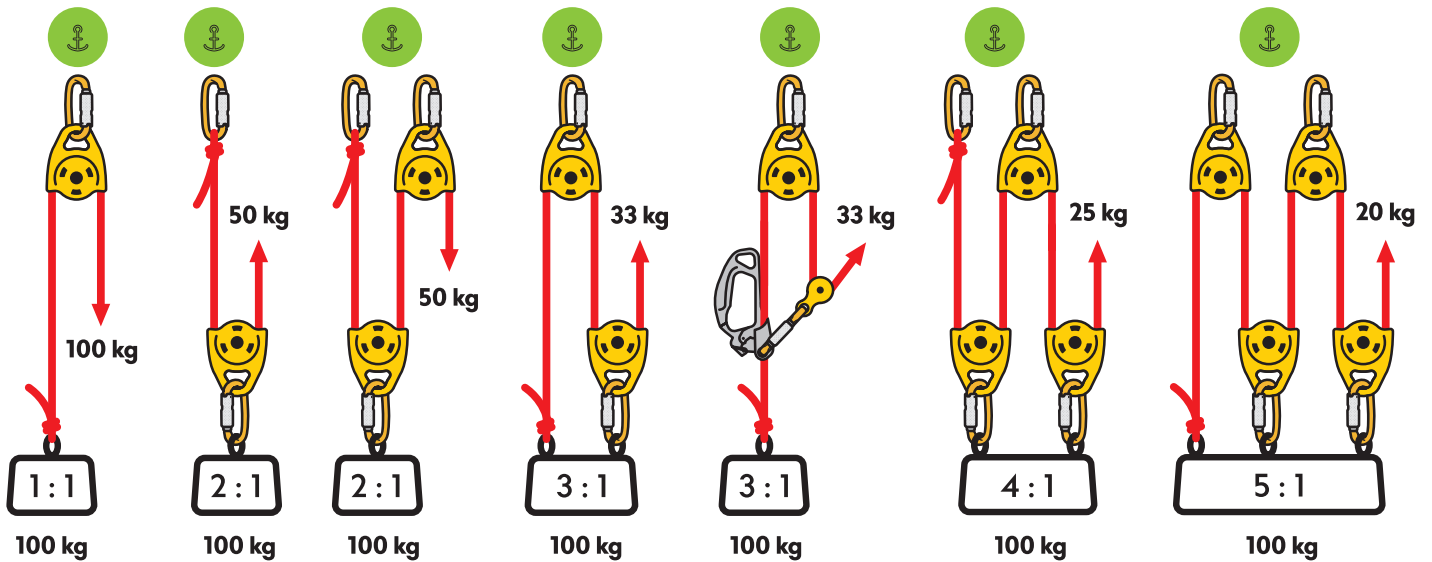



W0112BY
WIND MASTER
work harness for wind turbines maintenance

RECOMMENDED GEAR

W9607
BLAST
working helmet



RK804BX0R
LIFT
hand ascender



W1010BB09
LOCKER
guided type fall arrester



RK805BX00
CAM CLEAN
Chest ascender



K0119EE00
BORA triplelock
light alloy HMS carabiner



K4080ZO
D STEEL CONNECTOR
screw



K032SIR00
SIR
multipurpose device for rope acces



RK801EE00
PULLEY EXTRA
durable and lightweight pulley



RK808OS00
EXTRA PLUS
large pulley



L0450RR
STATIC R-44 11.0
150 m static rope



L045000
STATIC R-44 11.0
150 m static rope



W8100B
ROPE PROTECTOR



W004*120
EYE SLING
sewn sling



W1024BX
FOOTER II
ascender webing



W2300W150
LANYARD „I“



W4462X085
REACTOR 140 ROPES „Y“ 85 cm
shock absorber



ACCESSORIES

K9001BB00
PORTER XL
plastic holder



W0010YB
FRANKLIN



W0052B010
WORKING BAG



C0046BB
TARP DUFFLE



MILITARY AND SPECIAL FORCES

Complete range of black textile and metal (matt) products, including ropes and lanyards. Special ropes with unique features. Easy use of equipment in the cruelest conditions you can image. Handling in gloves, manipulation in a dark and quick releasing are obvious.

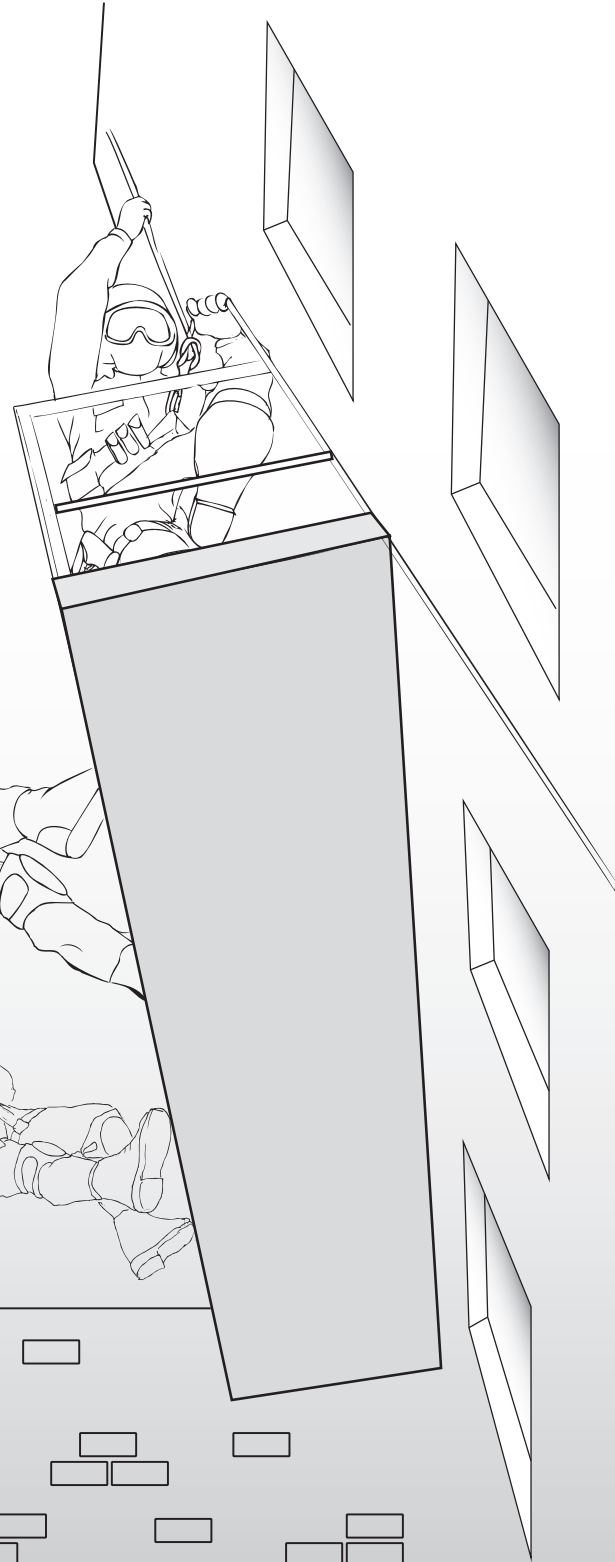
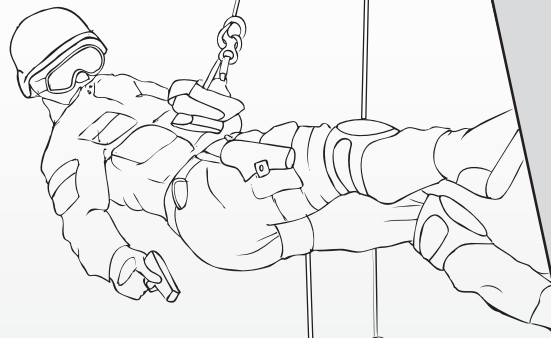
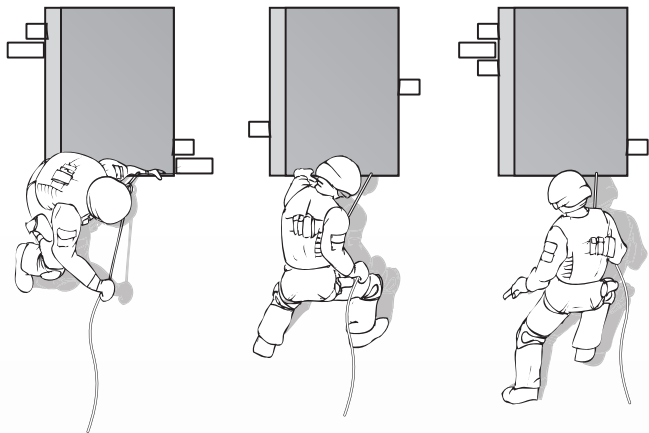

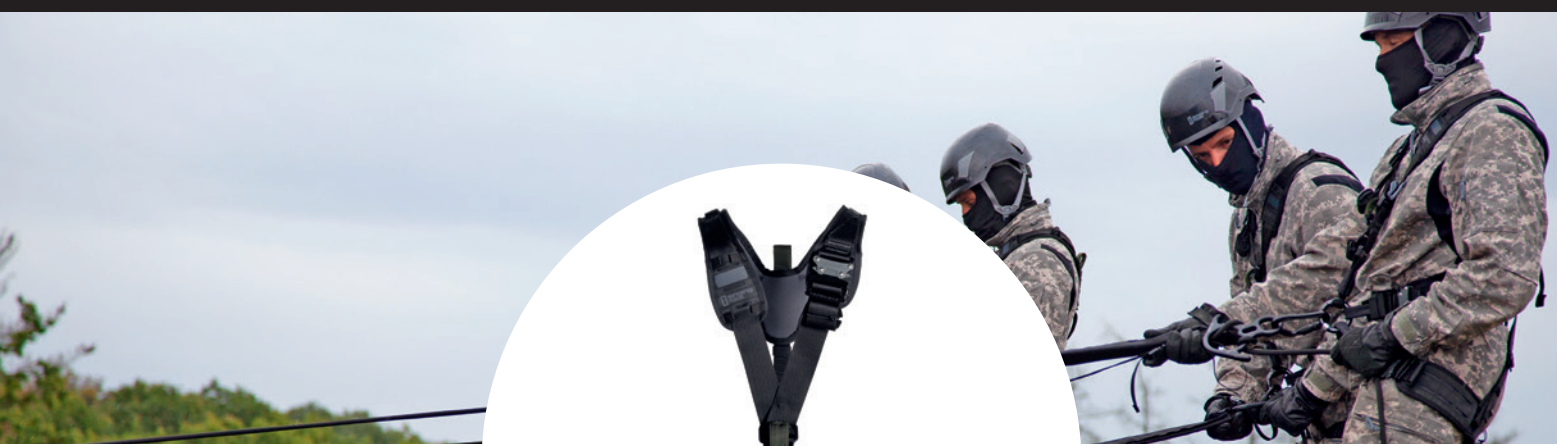

W0096BB
TACTIC MASTER

RECOMMENDED GEAR

X0033
FLASH INDUSTRY
work helmet



K0122BB06
OXY twist lock
light alloy carabiner



RK804BX0R
LIFT
hand ascender



K6180BB
RESCUE FIGURE EIGHT
special figure eight for rescue



K6132BB
BUDDY
belay tube



W1010BB09
LOCKER
guided type fall arrester



K032SIR00
SIR
multipurpose device for rope access



L0230BB
STATIC 10,5
static rope



W004*120
EYE SLING
sewn sling



W8100B
ROPE PROTECTOR



W0005BB09
LAIKA
dog harness



W1015B020
LOCKER SLING
certified sling for the Locker



ACCESSORIES

K9000BB03
PORTER
plastic holder



S9000BB35
GEAR BAG
35 l



W1026BB
URNA
leg rope bag



C0088SB
BALACLAVA PRO





CABLEWAY EVACUATION

Ski lift or gondola evacuations utilize specialized rescue techniques and gear that must perform regardless of weather conditions.

The success of evacuation operations begins with having the proper ski lift or gondola evacuation gear and proper training and practice of the operating personnel.

If the chair lift or gondola fails, the person in charge must evacuate passengers according to the evacuation plan. Evacuation of a ski lift requires specific techniques for movement along a cable. For maximum efficiency, these operations are led simultaneously by several independent teams.

Evacuation is a team effort and requires perfect coordination by everyone involved. SINGING ROCK team cooperates with ski resorts all over Czech Republic to improve rescue methods and develop a new gear.

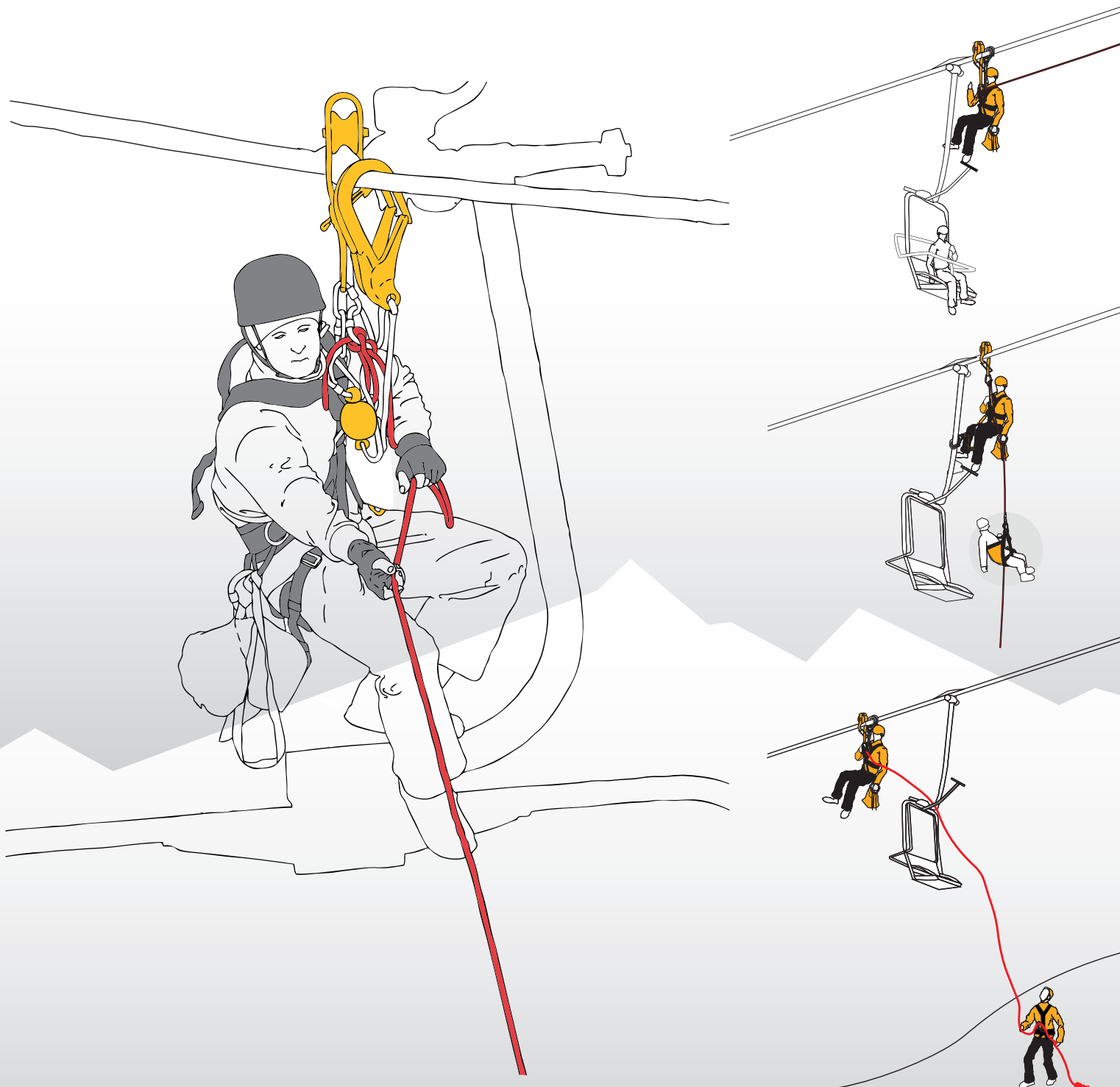



W0079DR
EXPERT 3D
 speed
 fully adjustable
 rope access
 harness

RECOMMENDED GEAR

W9603QX
FLASH ACCESS
 working helmet



K355OPP
CONNECTOR
GIGA



K6180ZO
RESCUE FIGURE EIGHT
 special figure eight
 for rescue



K0119EE00
BORA triplelock
 light alloy
 HMS carabiner



K4241Z005
OVAL STEEL
CONNECTOR
 triple lock



K82310Z
MAILLON BIG D
 steel maillon
 carabiner



K82008Z
MAILLON
SMALL OVAL
 steel maillon carabiner



L0250RR
Static 11.0
 static rope



W4400WW00
REACTOR 140
 shock absorber



W0003BY09
AXILLAR
 rescue sling



W2001*060
OPEN SLING
 seven sling,
 60 cm



RK809SO00
EASY LIFT
 rescue pulley



W8201BY00
EVACUATION
TRIANGLE SIT II



S9000YY35
GEAR BAG
 waterproof bag



BELAYER



INDEX

PRODUCT NAME	PAGE		PAGE		PAGE
ACCESSORIES	195	CABLEWAY EVACUATION SYSTEM	134	FIRST AID BAG – LARGE	144
ACCESSORIES	197	CAM CLEAN	94	FIXING MATERIAL FOR GROUND AND WALL	
ACCESSORY CORD	54	CANTILEVER ARM CONSOLE	110	SLEEVE	109
ACCESSORY CORDS	57	CARRY BAG	139	FLASH	77
ACCORD 8.3	51	CLASSIC ADAPTOR (PAIR)	84	FLASH ACCESS	78
ACCORD DRY 8.3	51	COLT / SCREW	62	FLASH AERO	78
ADJUST	122	COLT SCREW 3PACK	62	FLASH INDUSTRY	78
ALADIN	33	CONDOM	169	FLASH PADDING	87
ANCHORING	178	CONNECTION STRAP	27	FLAT WEBBING	122
ANTISHOCK I	21	CONNECTOR GIGA	67	FOOT LIFT	94
APOLLO PANTS	151	CONTRA 10.5	47	FOOTER II	126
APOLLO SHORTS	151	COVER	85	FOOTER XP	127
ARBO CHEST	33	COVER SMOKE	85	FORGING	70
ARBO MASTER	34	COW´S TAIL	53	FRANKLIN	31
ARBO SITE	121	CUBE	139	GEAR BAG	138
ATIKA ROPE PROTECTOR	54	CULTER	148	GEMINI DRY 7.9	52
AXILLAR	123	D – MOBILE	102	GLUE IN ANCHOR	102
BABY RESCUE BAG	37	D STEEL / SCREW	67	GRIPPY	147
BACK-UP	95	D STEEL / TRIPLE LOCK	67	GRIPPY 3/4	147
BALACLAVA PRO	162	DEFENDER	55	GROUND COFFEE OUTDOOR	165
BANNER BAG	168	DNA DRY 8.9	48	GYM 10.1	50
BANNERS	170	DOUBLE STOP PLUS	90	HAMMER CORD	54
BANTAM BEAMER	103	DRY BAG	139	HARNESS PADDING	27
BARK PULLEY SAVER	120	DRY DUFFLE	140	HECTOR / SCREW	60
BARK RING SAVER	121	DURAN 10.4	51	HECTOR / TRIPLE LOCK	60
BASEBALL HAT	160	DYNAMIC ROPES	56	HECTOR BC / SCREW	
BASEBALL HAT LIGHT	160	EASY LIFT	98	HECTOR BC / TRIPLE LOCK	60
BASIC	25	EDGE ROLLER	55	HELMETS	83
BASIC LIGHT	25	EDGE ROLLER – PART	55	HERO 9.6	49
BASIC PULLEY SYSTEMS	194	ELECTRIC ARC VISOR	84	HERO DRY 9.6	48
BEACH FLAG	170	EVACUATION SET	193	HEX	81
BEANIE	161	EVACUATION TRIANGLE COMBI II	36	HEX PADDING	87
BEANIE HAT	162	EVACUATION TRIANGLE SIT II	36	HOODY	155
BEANIE POLAR	161	EVAQ CASE WITH SEALING	113	HOODY FULL ZIP	156
BEANIE PRO	161	EVAQ HUB II	112	HOODY JUNIOR	157
BEER MAT	164	EVAQ ROPE	112	HOOK PARKING LOOP	28
BELAYER	199	EXPERT 3D / SPEED	12	HOT	70
BELT	166	EXPERT 3D / SPEED STEEL	13	ICON 9.3	48
BIG CONNECTOR	67	EXPERT 3D / STANDARD	13	ICON DRY 9.3	48
BIG SQUARE	66	EYE SLING	116	IKAR AAS-1 CANTILEVER ARM	108
BIG TWIST	66	FALCONER 3/4	146	IKAR DB-A3 TRIPOD	111
BLAST	76	FALCONER FULL	146	IKAR GROUND SLEEVE	108
BLAST PADDING	87	FALCONER TACTICAL	146	IKAR H	106
BODY II ENERGY SPEED	24	FALL ARRESTER SET	132	IKAR HRA	106
BODY II SPEED	23	FALL FACTOR	178	IKAR HRA TRIPOD CONSOLE	111
BODY II STANDARD	23	FAVORABLE COMBINATIONS	26	IKAR HWB	105
BORA / SCREW, BORA / TWL		FIGURE 8L	93	IKAR HWS	105
BORA / TRIPLE LOCK	61	FIGURE 8M	93	IKAR LOWER GROUND SLEEVE	109
BORA GP / SCREW	61	FINE LINE	123	IKAR LOWER GROUND SLEEVE CORE HOLE	109
BUDDY	92	FIRST AID BAG	144	IKAR MOBILE ATTICS BASE	110

IKAR MOBILE GROUND BASE	109	PENTA PADDING	87	ROOFER SET	132
IKAR PLW WINCH	111	PILOT R3	99	ROOFER SET	183
IKAR WALL SLEEVE	108	PITCHER	164	ROPE BAG	143
IKAR WINCH CANTILEVER ARM CONSOLE	110	POLE II	26	ROPE PROTECTOR	55
IKAR WINCH TRIPOD CONSOLE	111	POLO T-SHIRT	153	ROPEDANCER II	22
INDY EVO PLUS	91	POLYGON	174	ROPEMARKER	53
JACOB	126	PORTER	68	ROUTE 44	44
JACOB DYNEEMA	126	PORTER XL	68	SAFE 2 FLEX CARRIER	84
JINGLE II	119	POSTERS	171	SAFE NYLON MESH VISOR	84
JOULE	131	PPE INSPECTION SET	133	SAFE PC	
KATA 9.7	49	PRODUCTION		SAFE STEEL MESH VISOR	84
KATA DRY 9.7	49	PROFI WORKER 3D / SPEED	15	SCAFFOLDER SET	133
KEY HOLDER	166	PROFI WORKER 3D / STANDARD	16	SCAFFOLDER SET	181
KEYLOCK	70	PROTECTIVE CASE	140	SCARF	163
KIDS HOODY	157	PROTECTIVE SLEEVE FOR SRL	106	SCORE 10.1	50
KNOTS	179	PRUSIK SLING	118	SCORE DRY 10.1	50
LAIKA	36	PULLER	95	SEAMASTER 3D STAINLESS STEEL	21
LAMPFIX	87	PULLEY EXTRA	96	SECURE EARMUFFS	86
LANYARD "I"	117	PULLEY EXTRA PLUS	96	SHUTTLE	92
LANYARD "V"	117	PULLEY MIKY	97	SINGING ROCK PEN	169
LIFT	94	PULLEY SLING	118	SINGING ROCK STICKERS	170
LIST OF SINGING ROCK POLYGON TRAINING		PULLEY SMALL	97	SIR	90
CENTERS	176	PULLEY TWIN	96	SIT WORKER 3D / SPEED	30
LOCKER	95	RAMA	91	SIT WORKER 3D / STANDARD	30
LOCKER SLING	95	RAMA SET	91	SITE	100
MAILLON BIG D	66	REACTOR 140	128	SITE LANYARD	101
MAILLON BIG DELTA	66	RECOMMENDED GEAR	181	SLING LANYARD	117
MAILLON MINI OVAL	66	RECOMMENDED GEAR	183	SMALL CONNECTOR	66
MAILLON SMALL DELTA	66	RECOMMENDED GEAR	185	SNAKE BRACE	103
MAILLON SMALL OVAL	66	RECOMMENDED GEAR	187	SNAPBACK HAT	160
MINI D	68	RECOMMENDED GEAR	189	SPEED BELT	166
MINI D SCREW	69	RECOMMENDED GEAR	191	SPELEO	47
MINI D SCREW 40 PACK	69	RECOMMENDED GEAR	193	SPELEO R44 10.5	47
MINI PEAR	68	RECOMMENDED GEAR	195	SPELEO ROPES	57
MONTY BAG	141	RECOMMENDED GEAR	197	STAINLESS HANGER PLATE / WITH BOLT	102
MOVEMENT BAG	138	RECOMMENDED GEAR	199	STATIC 10.5	45
NOTEPAD A5	169	REDBLOCK	100	STATIC 11.0	45
NUMBER	70	REFLECT VEST	28	STATIC 9.0	46
OPEN SLING	116	RESCUE BAG	140	STATIC R44 10.5	44
OPEN SLING 14 MM	116	RESCUE FIGURE EIGHT	93	STATIC R44 11.0	44
OVAL STEEL / SCREW	67	RESCUE KNIFE	148	STATIC R44 NFPA 10.5	46
OVAL STEEL / TRIPLE LOCK	67	RESCUE POLE	145	STATIC R44 NFPA 11.0 (7/16")	46
OVERALL	149	RESCUE RATCHET	123	STATIC R44 NFPA 13.0 (1/2")	46
OXY / SCREW, OXY / TWL,	63	RESCUE SET	135	STATIC ROPES	56
OXY / TRIPLE LOCK	63	RETRACTABLE TYPE FALL ARRESTERS:	105	STEEL ANCHOR	125
OXY BC / SCREW, OXY BC / TWL	63	RIGGING PLATE 1/3	98	STEEL LANYARD "I"	125
OXY BC / TRIPLE LOCK	63	RIGGING PLATE 3/5	98	STITCHED EYE	44
OZONE / SCREW, OZONE /	65	RING	99	STORM 9.8	50
PALM CONNECTOR	67	RING SLING	119	STORM DRY 9.8	49
PAPER BAG	168	RINGO	99	STRAP FOR CAM CLEAN	94
PATRON 11.0	51	RL CHEST	33	SUSPENSION TRAUMA SAFETY STRAP	28
PATRON LANYARD	120	ROCK & LOCK	10	T - SHIRT BACKBONE JUNIOR	157
PENTA	79	ROCKLIFE T-SHIRT LONG SLEEVE	154	TACTIC MASTER	20
PENTA JUNIOR	80	ROOF MASTER	19	TANDEM PULLEY	97

TARP DUFFLE	138	TRACK PLUS	122	UNIQUE	
TARZAN ECONOMIC	22	TRAVEL MUG	165	URBAN II	31
TECH INFO EN	171	TREE ANCHOR	121	URNA	142
TECHNIC	17	TREEMOUSE	145	USB FLASH DRIVE	167
TECHNIC ANSI	17	TRIPOD BAG	141	VERTICAL FIXED BEAM CLAMP	103
TECHNIC PADDING	27	TRUCKER HAT	160	WHOLE BEAN COFFEE CAN	164
TECHNOLOGY	70	T-SHIRT ACTIVE LONG SLEEVE	155	WIND MASTER	18
TEXTILE BADGE	168	T-SHIRT BACKBONE	152	WORK KNIFE	148
THERMOCUTTER	53	T-SHIRT COOL	154	WORKING BAG	142
THROW LINE	54	T-SHIRT MONKEY	156	WORKING PANTS	149
TILIA 11.5	47	T-SHIRT ROCKET	152	WRISTBAND	168
TIMBER ACCESSORY CORD	118	T-SHIRTS BLUE MOUNTAIN	153	XSTREAM LD	86
TOOL BAG	142	TUBULAR WEBBING	122	ZINC PLATED HANGER PLATE / WITH BOLT	102
TOOL HOLDER	127	TWISTER	100		
TOOL HOLDER MAX	127	TWL, OZONE / TRIPLE LOCK	65		
TOOLKIT	141	ULTRASONIC	44		





INDEX

PRODUCT NUMBER	PAGE		PAGE		PAGE
A4072YX04	106	C0090BB00	161	K0018BB00	65
W0078DB	13	C0091	79	K0027BY00	69
W0079DB	12	C0091FX02	79	K0027BY40	69
W0082DB	15	C0091FX03	79	K0027YX00	69
W9602QX00	78	C0091FX05	79	K0030OG00	100
1RK715XX12	102	C0091GX02	79	K0043OX00	91
A0002SS01	102	C0091GX03	79	K0043SX00	91
A0031BS	148	C0091GX05	79	K0050OS01	55
A003OY	148	C0091JY02	80	K0050OS03	55
A0050HH00	148	C0091SX02	79	K0101BX00	91
A4000S060	105	C0091SX03	79	K0107BB00	61
A4000S090	105	C0091SX05	79	K0107BP00	61
A4000SI20	105	C0091YX02	79	K0107EE00	61
A4000S240	105	C0091YX03	79	K0107EP00	61
A4000W018	105	C0091YX05	79	K0108BB00	61
A4000W028	105	C0092XX	87	K0108EE00	61
A4000W035	105	C0900AX03	81	K0112BB00	62
A4002BS33	106	C0900AX04	81	K0112EE00	62
A4002BS42	106	C0900MX03	81	K0112XX30	62
A4004BS12	106	C0900MX04	81	K0114BB00	60
A4004BS18	106	C0900RX03	81	K0114BC00	60
A4004BS33	106	C0900RX04	81	K0114EC00	60
A4064XX30	111	C0900WX03	81	K0114EE00	60
A4070XX00	141	C0900WX04	81	K0119BB00	61
A4072YX	106	C0900YX03	81	K0119EE00	61
A4072YX02	106	C0900YX04	81	K0121BB00	60
A4072YX03	106	C0901SB	87	K0121BC00	60
C0001BB	143	CI013BB	152	K0121EC00	60
C0001YY00	139	CI014BB	152	K0121EE00	60
C0006BH	147	CI018BY	155	K0122BB05	63
C0006HH	147	CI019BY	156	K0122BB06	63
C0012YB	146	CI020BY	156	K0122BB07	63
C0013YB	146	CI028VX	152	K0122EE05	63
C0014YB	146	CI029VX	152	K0122EE06	63
C0035AO12	122	CI030Y	156	K0122EE07	63
C0037BB12	122	CI031M	157	K0123BC05	63
C0037RR12	122	CI032MM	153	K0123BC06	63
C0046BI20	138	CI033MM	153	K0123BC07	63
C0046BB70	138	CI034SS0	151	K0123EC05	63
C0046BB90	138	CI035SS0	151	K0123EC06	63
C0051BH	160	CI036VX	154	K0123EC07	63
C0051HH	160	CI037AX	154	K0124ST09	67
C0053RW	144	CI038B	157	K0124SY09	67
C0054BX	161	CI039B	157	K031DSD00	90
C0055BX	161	C2150BY	126	K032SIR00	90
C0058RR00	144	C2151BY00	126	K04000BB	95
C0069	162	C5056	33	K3536PP00	67
C0069BG00	162	C9091XX	166	K3550PP00	67
C0069PB00	162	C9092BX	166	K3690ZO	66
C0070SL00	160	C9092XX	166	K3702PP	66
C0073BY00	138	E0015XX	53	K4080ZO	67
C0074BY00	160	K0006RP00	100	K4081ZO	67
C0079BX00	163	K0016AA00	65	K4241ZO05	67
C0080BX00	163	K0016BB00	65	K4241ZO07	67
C0087SB	161	K0017AA00	65	K5052EE00	68
C0088SB	162	K0017BB00	65	K5182EE00	68
C0089SX00	160	K0018AA00	65	K6021BB	93

K602IEE	93	L3050RY00	50	RK714BB00	98
K603IBB	93	L3060CX	48	RK715XX10	102
K603IEE	93	L9031YX10	54	RK716XX10	102
K6132BB	92	L9991WB	133	RK716XX12	102
K6132EE	92	M0000XSET	133	RK800BB00	97
K6140BB00	92	M0020X1	132	RK800EE00	97
K6140EE00	92	M0020X2	132	RK801BB00	96
K6180BB	93	M0021XX	133	RK801EE00	96
K7002BX46	99	M0022XX	132	RK802BB00	96
K82006Z	66	M0030X030	135	RK802EE00	96
K82008Z	66	M0030X050	135	RK803BB00	97
K82207Z	66	M0030X100	135	RK804BXOL	94
K82210Z	66	M0201XX00	91	RK804BXOR	94
K82310Z	66	MK006	134	RK805BX00	94
K82410Z	66	P0010X030	164	RK806BB00	97
K82508Z	66	P0010X050	164	RK807BXOL	94
K9000BB03	68	P0019XX00	167	RK807BXOP	94
K9001BB00	68	P0020	170	RK808BB00	96
L0002	54	P0020BB02	170	RK808OS00	96
L0003	54	P0020BB03	170	RK809SO00	98
L0041 - L0081	54	P0020BB04	170	RK850X100	125
L0220BB	46	P0020BB05	170	RK850X130	125
L0220WR	46	P0021	170	RK850X180	125
L0230BB	45	P0021BB00	170	RK851XX03	125
L0230KK	45	P0021BB03	170	RK851XX05	125
L0230RR	45	P0021BB04	170	RK900PP00	54
L0230WR	45	P0021BB05	170	SI100BY	95
L0240WR	47	P0022XX00	169	S9000BB35	138
L0250BB	45	P0023XX00	169	S9000BB50	138
L0250RR	45	P0024XX00	168	S9000RR35	138
L0250WR	45	P0025XX00	170	S9000RR50	138
L026	47	P0027WX00	171	S9000YY35	138
L0340AX	51	P0028WE00	171	S9000YY50	138
L0360GG	50	P0030XX00	169	S9001BX60	139
L0364LA00	50	P0031XX01	168	S9001YX40	139
L0380YX	48	P0031XX02	168	S9003YB60	140
L0384RX	48	P0033XX00	168	S9003YY40	140
L0430BB	44	P0033XX02	168	W0003BY09	123
L0430KK	44	P0038GB10	165	W0005BB09	36
L0430RR	44	P0038W150	164	W0005YBO9	36
L0430WR	44	P0047XX01	164	W0008BS	142
L0440WR	47	P0047XX02	164	W0010BB	31
L0450BB	44	P0048X400	165	W0010YB	31
L0450OO	44	P0054XX00	168	W0022BB	31
L0450RR	44	P99100X	166	W0052B010	142
L0450WG	44	R0430BB	46	W0052B012	142
L0460OV00	47	R0430KK	46	W0059BR	22
L0468O	47	R0430RR	46	W0063BB	17
L0510	51	R0430WR	46	W0064BB	17
L0514	51	R0450BB	46	W0068BB	23
L0520GW	49	R0450OO	46	W0068BR	23
L0524GW	48	R0450RR	46	W0071BB	23
L0540B450	53	R0450WG	46	W0071BY	23
L0540BB00	51	R0460WB	46	W0073	26
L0540C450	53	RK400BB	99	W0074DR	21
L0540YX	51	RK702XX10	102	W0075DB	30
L057AA	49	RK702XX12	102	W0075DR	30
L0580AA	49	RK703XX10	102	W0076DB	30
L3020	52	RK704XX10	102	W0076DR	30
L3040GA00	50	RK704XX12	102	W0078DR	13
L3044AG00	49	RK713BB00	98	W0079DR	12

W0080DR	13	W2004*080	116	W4420W085	129
W0081DB	16	W2004*120	116	W4420W155	129
W0081DR	16	W2004*150	116	W4421W085	129
W0082DR	15	W2005	116	W4421W155	129
W0085BB00	94	W2005A080	116	W4422W085	129
W0086B0	21	W2005B060	116	W4422W155	129
W0087BY	22	W2005B080	116	W4423W085	129
W0089SY	25	W2005B120	116	W4423W155	129
W0090SY	25	W2005B150	116	W4430W155	129
W0091BY	19	W2005R120	116	W4433W155	129
W0092BB	27	W2005W150	116	W4440W155	129
W0093SY	24	W2005Y060	116	W4441W155	129
W0096BB	20	W2016*060	117	W4442W155	129
W0097BB00	27	W2016*080	117	W4450X085	129
W0102YB00	28	W2016*120	117	W4450X155	129
W0103BB	17	W2016*150	117	W4452X085	129
W0104BB	17	W2018A060	103	W4452X155	129
W0105BR	34	W2018Y030	103	W4453X085	129
W0108BR00	33	W2020X080	27	W4453X155	129
W0109RX00	34	W2111Y	120	W4460X085	129
W0110RX00	34	W2112Y	120	W4460X155	129
W0112BY	18	W2113Y	120	W4462X085	129
W0200BB	33	W2114	121	W4462X155	129
W1001WW10	123	W2115	120	W4463X085	129
W1001WW15	123	W2116	121	W4463X155	129
W1001WW20	123	W2117	121	W4470Y100	129
W1002WO20	123	W2200	117	W4471Y100	129
W1002WS10	123	W2200*001	117	W4472Y100	129
W1002WY15	123	W2200*002	117	W4474Y100	129
W1010BB09	95	W2200*100	117	W4480X085	129
W1011WB02	100	W230	117	W4480X155	129
W1011WB04	100	W2300*060	117	W4482X085	129
W1012WB02	100	W2300*080	117	W4482X155	129
W1012WB04	100	W2300*120	117	W4483X085	129
W1015B020	95	W2300*150	117	W4483X155	129
W1023	141	W2301*060	117	W4484X085	129
W1024BX	126	W2301*080	117	W4484X155	129
W1025BX	126	W2301*120	117	W8000BX00	145
W1026BB	142	W2301*150	117	W8100B	55
W1027B	55	W2303*060	117	W8201BY00	36
W1028BY00	127	W2303*080	117	W8211BY00	36
W1029BX00	28	W2303*120	117	W8220	37
W1036W130	122	W2303*150	117	W9002XX17	140
W1040R	119	W2601R085	118	W9002XX46	140
W1041R	119	W2602Y085	118	W9003RX45	140
W1042R	119	W2603YB00	118	W9004YX00	141
W1047Y100	122	W2604RR00	119	W9005YB00	139
W1051BX	127	W2608	118	W9500Y	145
W1052XX00	123	W2610	118	W9601BB00	78
W1054BR00	127	W4100Y070	131	W9601QX00	78
W1520X	112	W4100Y120	131	W9601RX00	78
W1521X000	112	W4100Y160	131	W9601WX00	78
W1522	113	W4400WW00	128	W9601YX00	78
W2001	116	W4410W085	129	W9602RX00	78
W2001	117	W4410W155	129	W9603QX00	78
W2001*060	116	W4411W085	129	W9603RX00	78
W2001*080	116	W4411W155	129	W9604BX00	87
W2001*120	116	W4412W085	129	W9605TT00	85
W2001*150	116	W4412W155	129	W9605XX00	85
W2004	116	W4413W085	129	W9606SX00	87
W2004*060	116	W4413W155	129	W9607	76

W9607BX00	76	X0015XX00	133	X0069XXR3	99
W9607MX00	76	X0016XX00	133	X0075XX14	103
W9607RX00	76	X0017XX00	133	X0077XX00	103
W9607WX00	76	X0018XX00	133	X4002XX00	111
W9607YX00	76	X0020XX00	133	X4003XX00	111
W9607ZX00	76	X0021XX11	133	X4005XX00	108
W9608SX00	87	X0022XX11	133	X4006XX00	108
W9801BY	149	X0023X200	133	X4007XX00	108
W9802BY	153	X0048XX25	86	X4008XX00	109
W9803BY	149	X0048XX29	86	X4009XX00	109
W9804YX	28	X0048XX31	86	X4010XX00	109
W9805BX	155	X0049XX00	84	X4011XX00	109
W9806BX	154	X0050XX00	84	X4012XX00	110
X0004GB	53	X0051XX00	84	X4013XX00	110
X0004GB00	133	X0052XX00	84	X4014XX00	110
X0013XX02	133	X0053XX00	84	X4015XX00	110
X0014XX00	133	X0062XX00	86		





Rock&Lock

Patented smart buckle used on SINGING ROCK harnesses and other products enables to lock and open very quickly.



Lady fit

Specially designed products for women.



Route 44

SINGING ROCK patented technology for rope production. A rope is produced on 44 carrier machine which provides great handling, low weight and durability.



Inter Core

The unique patented technology providing maximum safety even in case of a damaged sheath. The rope is made from 4 layers of parallel core filaments, braided core, braided intermediate sheath made from staple fibres and single tech sheath.



Single Tech

With the Single Tech system each strand is braided into the sheath separately. Single Tech sheath construction increases the rope's wear resistance and improves the rope's mechanical properties, such as flexibility.



Single rope

Marking of single dynamic rope for climbing and mountaineering used in single strand.



Half rope

Marking of half rope for mountaineering, multipitch and ice climbing. Individual strands of rope are used in alternation in the protection system. This system reduces the risk of rope breakage caused by falling stones, and provides maximum safety in alpine conditions and for difficult climbs.



Twin rope

Marking of twin ropes for mountaineering, multipitch and ice climbing. Pairs of the same type of rope are always used, sharing the same protection points. Twin ropes guarantee a high level of safety, especially for multipitch climbing in alpine conditions.



Stitched eye

sewn loop at the end of kernmantle low stretch rope used as a substitute of a knot. Used mainly to attach ropes to anchor or attachment points.



UIAA

Products marked with this symbol meet strict UIAA safety requirements. The UIAA is the International Mountaineering and Climbing Federation. In most cases, UIAA requirements are sometimes stricter than EN standards.



UIAA Water repellent

A standard for water repellent ropes approved by the UIAA Safety Commission. To pass the test at a certified laboratory, the amount of absorbed water must not be greater than 5% of the rope's weight. For comparison, a non-treated rope absorbs around 50% of water in this test, and ropes labelled as „dry“ but lacking adequate treatments can absorb between 20% and 40% of water.



Symbol of compliance

The CE symbol declares that the product is in compliance with the safety requirements of the applicable European standard. The number after the symbol CE (e.g. CE 1019) identifies the relevant accredited testing lab.



ANSI

American National Standards Institute – is a private non-profit organization that oversees the development of voluntary consensus standards for products, services, processes, systems, and personnel in the United States.[3] The organization also coordinates U. S. standards with international standards so that American products can be used worldwide.



NFPA

The National Fire Protection Association is a US nonprofit organization devoted to eliminating death, injury, property and economic loss due to fire, electrical and related hazards. It is widely known as an organization that creates and maintains standards and codes for usage and adoption by local governments.

ABS	Acrylonitrile butadiene styrene is a common thermoplastic polymer. The most important mechanical properties of ABS are impact resistance and toughness. ABS is stronger than pure polystyrene.
Acryl	Lightweight, soft, and warm, with a wool-like feel fabrics or yarn. Strong and warm, acrylic fiber is often used for sweaters and tracksuits and as linings for boots and gloves, as well as in furnishing fabrics and carpets. It is manufactured as a filament, then cut into short staple lengths similar to wool hairs, and spun into yarn.
Anodizing	Electrolytic passivation process used to increase the thickness of the natural oxide layer on the surface of metal parts. Anodizing increases resistance to corrosion and wear, and provides better adhesion for paint primers and glues than bare metal does.
Bamboo	Cloth, yarn, and clothing made out of bamboo fibres. Bamboo fabric is exceptionally soft and light. It is also incredibly hydrophilic, absorbing more water than other conventional fibres such as cotton and polyester.
Cold forging	Deformation of metal while it is below its recrystallization point. This process is usually less expensive than hot forging and the end product requires little, if any, finishing work. Residual stress of material may occur as it handles high stress and high die loads
Cordura	Brand name for a collection of fabrics used in a wide array of products including luggage, backpacks, trousers, military wear and performance apparel. Cordura fabrics are known for their durability and resistance to abrasions, tears and scuffs. Cordura fabrics are usually made of nylon.
Cortex	Polyamide elastic woven fabrics. Cortex fabrics are designed to ensure the maximum ergonomics and comfort.
Dyneema	Registered trademark for a synthetic fabric that is stronger than Kevlar®. Dyneema® is composed of ultra high molecular weight polyethylene. It is resistant to water, most chemicals, UV radiation and bacterial.
ED coating	Electrophoretic deposition coating. A characteristic feature of this process is that colloidal particles suspended in a liquid medium migrate under the influence of an electric field (electrophoresis) and are deposited onto an electrode.
Elastane (Spandex)	Synthetic polyether-polyurea copolymer known for its exceptional elasticity. It is stronger and more durable than natural rubber.
EPS	Expanded polystyrene is a rigid and tough, closed-cell foam. It is made of pre-expanded polystyrene beads. Due to its technical properties such as low weight, rigidity, and formability, EPS can be used in a wide range of different applications.
Fiber glass	Type of fiber-reinforced plastic where the reinforcement fiber is specifically glass fiber. The glass fiber may be randomly arranged, flattened into a sheet (called a chopped strand mat), or woven into a fabric. Fiberglass is unique in its strength and yet it is lightweight. Although it is not as strong and stiff as composites based on carbon fiber, it is less brittle, and its raw materials are much cheaper.
Fleece	Soft napped insulating fabric made from a type of polyester called polyethylene terephthalate (PET) or other synthetic fibers. A lightweight, warm, soft and hydrophobic fabric. Regular polar fleece is not wind-proof and does not absorb moisture. It readily generates static electricity.
G10 fiber	High-pressure fiberglass laminate, a kind of composite material. It is created by stacking multiple layers of glass cloth, soaking in epoxy resin, and compressing the resulting material under heat until the epoxy cures. G10 is favoured for its high strength, low moisture absorption, excellent electrical insulating properties and chemical resistance.
HF welding	Joining of materials by supplying High Frequency energy in the form of an electromagnetic field (27.12 MHz) and pressure to the material surfaces to be joined.
Hot forging	Deformation of metal while it is above the recrystallization point. Hot forging is recommended for the deformation of metal that features a high formability ratio. Hot forging provides a homogenized grain structure
Injection	Manufacturing process for producing parts by injecting material into a mould. Material for the part is fed into a heated barrel, mixed, and forced into a mould cavity, where it cools and hardens to the configuration of the cavity.
Kernmantle rope	Rope constructed with its interior core protected by a woven exterior sheath designed to optimize strength, durability, and flexibility. The core fibers provide the tensile strength of the rope, while the sheath protects the core from abrasion during use.
Kevlar	Kevlar is the registered trademark for a para-aramid synthetic fiber. Kevlar has many applications, ranging from bicycle tires and racing sails to body armor, because of its high tensile strength-to-weight ratio; by this measure it is 5 times stronger than steel. It is designed to protect users from cuts, abrasions and heat. Kevlar-based protective gear is often considerably lighter and thinner than equivalent gear made of more traditional materials.
Nylon	Generic designation for a family of synthetic polymers, based on aliphatic or semi-aromatic polyamides. Nylon is a thermoplastic silky material that can be melt-processed into fibers, films or shapes. Nylon is very much suitable for hosiery and the knitted fabrics because of its smoothness, light weight and high strength.
Polyamide (PA, PAD)	Macromolecule with repeating units linked by amide bonds. Synthetic polyamides are commonly used in textiles, automotive applications, carpets and sportswear due to their high durability and strength. Fibres are very tear-proof and abrasion-resistant and absorb little moisture (thus good transport of moisture away from the body) and are stretchy, crease-free, but also prone to pilling. Polyamide has the highest resistance of all textile raw materials (also when wet) and is very stretchy.
Polycarbonate	Group of thermoplastic polymers containing carbonate groups in their chemical structures. Polycarbonates used in engineering are strong, tough materials, and some grades are optically transparent.
Polyester (PES)	Category of polymers that contain the ester functional group in their main chain. Fabrics woven or knitted from polyester thread or yarn are used extensively in apparel and home furnishings. Industrial polyester fibers, yarns and ropes are used in car tire reinforcements, fabrics for conveyor belts, safety belts, coated fabrics and plastic reinforcements with high-energy absorption. Polyester has excellent return conduct thanks to the rippling property and is very light. Polyester also retains its shape and is colourfast, as well as resistant to sweat and UV-rays (lightfast). Polyester has a high melting point and transfers can therefore be printed on this material)
Polyethylene (PE)	Most common plastic, which is usually a mixture of similar polymers of ethylene. Polyethylene is of low strength, hardness and rigidity, but has a high ductility and impact strength as well as low friction. It shows strong creep under persistent force, which can be reduced by addition of short fibers. Its primary use is in packaging (plastic bags, plastic films, geomembranes, containers including bottles, etc.)
POLYMAR	Registered trademark for a polyester coated with polyurethane tarpaulin fabric. It is UV and weatherproof resistant.
Polypropylene (PP)	Thermoplastic polymer used in a wide variety of applications including packaging and labeling, textiles (e.g., ropes, thermal underwear and carpets), stationery, plastic parts and reusable containers of various types, laboratory equipment, loudspeakers, automotive components and polymer banknotes. An addition polymer made from the monomer propylene, it is rugged and unusually resistant to many chemical solvents, bases and acids. Polypropylene is the world's second-most widely produced synthetic plastic, after polyethylene.
Polystyrene	Synthetic aromatic polymer made from the monomer styrene. Polystyrene can be solid or foamed. General-purpose polystyrene is clear, hard, and rather brittle. Polystyrene is one of the most widely used plastics. Uses include protective packaging (such as packing peanuts and CD and DVD cases), containers (such as "clamshells"), lids, bottles, trays, tumblers, and disposable cutlery.
Polyvinyl chloride (PVC)	World's third-most widely produced synthetic plastic polymer, after polyethylene and polypropylene. PVC comes in two basic forms: rigid and flexible. The rigid form of PVC is used in construction for pipe and in profile applications such as doors and windows. It is also used for bottles, other non-food packaging, and cards (such as bank or membership cards). In flexible form, it is used in plumbing, electrical cable insulation, imitation leather, signage, phonograph records, inflatable products, and many applications where it replaces rubber.
Polyurethane (PU)	Polymer composed of organic units joined by carbamate (urethane) links. While most polyurethanes are thermosetting polymers that do not melt when heated, thermoplastic polyurethanes are also available.
Ripstop	Woven fabrics, using a special reinforcing technique that makes them resistant to tearing and ripping. During weaving, (thick) reinforcement threads are interwoven at regular intervals in a crosshatch pattern. Advantages of ripstop are the favourable strength-to-weight ratio and that small tears can not easily spread.
Stainless Steel	Steel alloy with a minimum of 10.5% chromium content by mass. Stainless steel is notable for its corrosion resistance. Stainless steel does not readily corrode, rust or stain with water as ordinary steel does. However, it is not fully stain-proof in low-oxygen, high-salinity, or poor air-circulation environments.
Technora	Registered trademark for an aramid that is useful for a variety of applications that require high strength or chemical resistance. It is closely related to Kevlar (see Kevlar).
Thermolite	Synthetic material made by Invista and used as an insulator. The performance fibers are engineered with a differentiated fiber shape, able to produce battings with sought-after lightweight warmth.
Thermotransfer	Digital printing process in which material is applied to paper (or some other material) by melting a coating of ribbon so that it stays glued to the material on which the print is applied.
Ultrasonic finishing	Sound waves with frequencies higher than the upper audible limit of human hearing is joining the load-bearing core and the protective sheath into a compact unit. It is used to finish kernmantle ropes ends.
Velcro	Registered trademark for a hook-and-loop fastener, which consists of two components: typically, two lineal fabric strips (or, alternatively, round "dots" or squares) which are attached (sewn or otherwise adhered) to the opposing surfaces to be fastened.
Zinc plating	Prevents oxidation of the protected metal by forming a barrier and by acting as a sacrificial anode if this barrier is damaged.

STANDARDS

The list of EN and US standards for personal protective equipment (PPE) against falls from a height



EN 341
PPE against falls from height. Descender devices for rescue.



EN 566
Mountaineering equipment – Slings



EN 12275
Mountaineering equipment – Connectors



EN 353-1, 2
PPE against falls from a height. Guided type fall arresters.



EN 567
Mountaineering equipment. Rope clamps.



EN 12277
Mountaineering equipment – Harnesses



EN 354
PPE against falls from a height. Connecting equipment max. length 2m (incl. connectors).



EN 795, EN 795 /A1
PPE against falls from a height. Anchor devices.



EN 12278
Mountaineering equipment. Pulleys.



EN 355
PPE against falls from a height. Energy absorbers.



EN 813
PPE against falls from a height. Sit harnesses.



EN 12492
Mountaineering equipment – Helmets for mountaineers



EN 358
PPE for work positioning and prevention of falls from a height. Work positioning systems.



EN 892
Mountaineering equipment. Dynamic (stretch) ropes.



EN 12841
PPE against falls from a height. Descender device for rope access system and rope adjustment devices.



EN 360
PPE against falls from a height. Retractable type fall arresters.



EN 959
Mountaineering equipment – Rock anchors



EN 15151
Mountaineering equipment – Braking devices



EN 361
PPE against falls from a height. Full body harnesses.



EN 1496
Rescue equipment. Rescue lifting devices.



ANSI Z359.1
Safety Requirements for Personal Fall Arrest Systems, Subsystems and Components



EN 362
PPE against falls from a height. Connectors.



EN 1497
Rescue equipment. Rescue harnesses.



CEN/TS 16415
Recommendations for anchor devices for use by more than one person simultaneously



EN 388
Protection gloves against mechanical risks



EN 1498
Personal fall protection equipment – Rescue loops



NFPA Class II
defined by NFPA 1983 as being designed to fit around the waist and thighs or under the buttocks and may be utilized for a maximum of a two-person load



EN 397
PPE against falls from a height. Industrial safety helmets.



EN 1808
Safety requirements for suspended access equipment



NFPA Class III
defined by NFPA 1983 as being designed to fit around the waist and thighs or under the buttocks and over both shoulders, rated for as maximum of a two-person load and is designed to prevent inverting



EN 564
Mountaineering equipment – Accessory cords



EN 1891
PPE against falls from a height. Low stretch kernmantel ropes.

THAT'S SINGING ROCK

Our company is located in the Czech Republic, in the heart of Europe. Our headquarter is near Krkonoše National Park and Bohemian Paradise where the amazing and unique sandstone rock climbing areas are situated. Most of our staff are climbers or workers at height, alpinists or backcountry skiers. All of us love the vertical playground. The great group of people who create the true SINGING ROCK culture is the priceless benefit for most of us who work at the company. We develop and manufacture gear for the vertical world as if it were for us. Most of the manufacturing is handmade and so thousands of finished products or their parts pass through our hands. Over the course of 30 years of SINGING ROCK, many people have taken turns at the machines and computers but some of them have been here almost from the beginning.

We are climbers who work for climbers

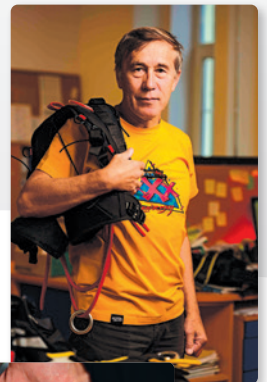

Warning:

Activities at height such as climbing, via ferrata, caving, rappelling, ski-touring, rescue, work at height and exploration are dangerous activities, which may lead to severe injury or even death. Thus the following is essential before use: careful reading and understanding of the instructions for use acquaintance with the possibilities and limitations of the product adequate apprenticeship in appropriate techniques and methods of use understanding and acceptance of the risk involved. In case of doubt or problem of understanding, contact SINGING ROCK.



Address:

Singing Rock
Poniklá 317
512 42 Poniklá
Czech Republic

Contact:

tel.: +420 481 585 007
e-mail: info@singingrock.com
www.singingrock.com

Social:

 [singingrock.page](#)
 [singingrock_official](#)
 [user/sigrvideo](#)

Catalogue PROFESSIONAL SINGING ROCK 2024 / 25 - PPE equipment

Published by: SINGING ROCK s.r.o. • Copyright © SINGING ROCK s.r.o.

All rights reserved. No part of this publication may be reproduced, distributed, or transmitted in any form or by any means, including photocopying, recording, or other electronic or mechanical methods, without the prior written permission of the publisher, except in the case of brief quotations embodied in critical reviews and certain other noncommercial uses permitted by copyright law. Technical specifications may change without notice.

**SAFETY
FIRST**

